

PROPRIETARY NOTE

THIS SPECIFICATION IS THE PROPERTY OF BOE HF AND SHALL NOT BE REPRODUCED OR COPIED WITHOUT THE WRITTEN PERMISSION OF BOE HF AND MUST BE RETURNED TO BOE HF UPON ITS REQUEST



SPEC. NUMBER S8-*	PRODUCT GROUP TFT- LCD	REV. P0	ISSUE DATE 2020-11-15	PAGE 1 OF 33
----------------------	---------------------------	------------	--------------------------	-----------------

B3 EV121WXM-N12 Product Specification Rev.P0

BUYER	
SUPPLIER	HEFEI BOE Optoelectronics Technology CO., LTD
FG-Code	EV121WXM-N12-3GP0

ITEM	BUYER SIGNATURE	DATE
_____	_____	_____
_____	_____	_____
_____	_____	_____

ITEM	SUPPLIER SIGNATURE	DATE
Prepared	<u>张晓磊</u>	<u>2020.11.15</u>
Reviewed	<u>王盛 王贺陶</u>	_____
Approved	<u>李乘揆 布占场</u>	_____

PRODUCT GROUP	REV	ISSUE DATE	BOE
TFT- LCD PRODUCT	P0	2020-11-15	

SPEC. NUMBER S8-*	SPEC . TITLE B3 EV121WXM-N12 Product Specification	PAGE 2 OF 33
----------------------	---	-----------------

REVISION HISTORY

(√) preliminary specification

() Final specification

REV.	ECN No.	DESCRIPTION OF CHANGES	DATE	PREPARED
P0		Initial Release	2019-11-15	张晓磊

--	--	--	--	--

PRODUCT GROUP

REV

ISSUE DATE



TFT- LCD PRODUCT

P0

2020-11-15

SPEC. NUMBER

SPEC. TITLE

PAGE

S8-*

B3 EV121WXM-N12 Product Specification

3 OF 33

Contents

No.	Items	Page
1.0	General Description	4
2.0	Absolute Maximum Ratings	6
3.0	Electrical Specifications	7
4.0	Optical Specifications	17
5.0	Reliability Test	22
6.0	Packing Information	23
7.0	Product Label	25
8.0	Handling & Cautions	26
9.0	Appendix	32

PRODUCT GROUP		REV	ISSUE DATE	BOE
TFT- LCD PRODUCT		P0	2020-11-15	
SPEC. NUMBER	SPEC. TITLE			PAGE
S8-*	B3 EV121WXM-N12 Product Specification			4 OF 33

1.0 GENERAL DESCRIPTION

1.1 Introduction

EV121WXM-N12 is a color active matrix TFT LCD module using amorphous silicon TFT 's (Thin Film Transistors) as an active switching devices. This module has a 12.1inch diagonally measured active area with WVGA resolutions (1280 horizontal by 800 vertical pixel array). Each pixel is divided into RED, GREEN, BLUE dots which are arranged in vertical stripe and this module can display 16.2M colors.

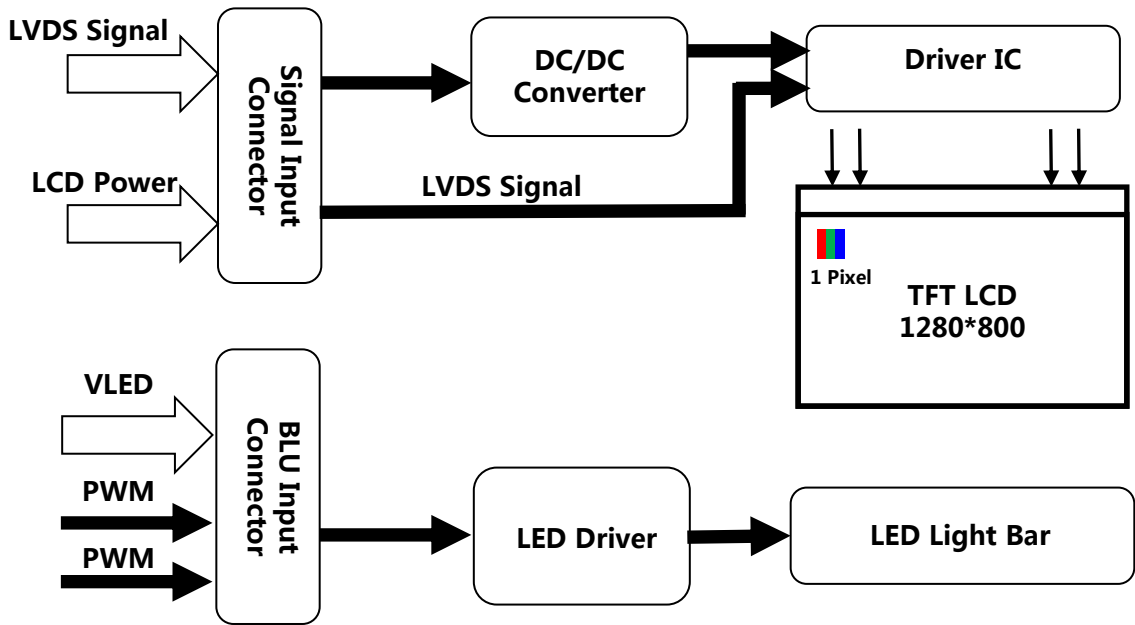

1.2 Features

- 0.5T Glass (Single)
- Normal Type
- 6/ 8bits LVDS data input selection
- Thin and light weight
- High luminance and contrast ratio, low reflection and wide viewing angle
- RoHS compliant

1.3 Application

- [Monitoring](#)

1.4 General Specification

The followings are general specifications at the ET104S0M-N11

<Table 1. LCD Module Specifications>

Parameter	Specification	Unit	Remarks
Active Area	261.12(H) x 163.20 (V)	mm	
Number Of Pixels	1280(H)×800(V)	pixels	
Pixel Pitch	68*204	mm	
Pixel Arrangement	Transmissive		
Display Mode	Normally Black		
Display Colors	16.7M(6bit +Hi-FRC)	colors	6+FRC
Surface Treatment	AG25		
Contrast Ratio	1200typ/1000min		
Viewing Angle(CR>10)	85°/85°/85°/85°	deg.	U/D/L/R
Response Time	30typ/35max	ms	
Color Gamut	72%		NTSC
Brightness	500	cd/m2	Typ.
Brightness Uniformity	80%		Typ.
Power Consumption	8.11	watt	Max.
Outline Dimension	277.7 (H) x 180.6(V)	mm	
Weight	TBD	gram	
Display Orientation	Landscape Only		

PRODUCT GROUP		REV	ISSUE DATE	BOE
TFT- LCD PRODUCT		P0	2020-11-15	
SPEC. NUMBER	SPEC. TITLE			PAGE
S8-*	B3 EV121WXM-N12 Product Specification			6 OF 33

2.0 ABSOLUTE MAXIMUM RATINGS

The followings are maximum values which, if exceed, may cause faulty operation or damage to the unit. The operational and non-operational maximum voltage and current values are listed in Table 2.

< Table 2. Absolute Maximum Ratings >

Parameter		Symbol	Min.	Max.	Unit	Remarks
Power Supply	LCD Module	VDD	0	3.9	V	Ta = 25 °C
	BLU	V _{BLU}	-	13.2	V	
		I _{BLU}	-	620	mA	
Operating Temperature		T _{OP}	-20	+70	°C	Note 1
Storage Temperature		T _{ST}	-30	+80	°C	

Note : 1) Temperature and relative humidity range are shown in the figure below. Wet bulb temperature should be 39 °C max. and no condensation of water.

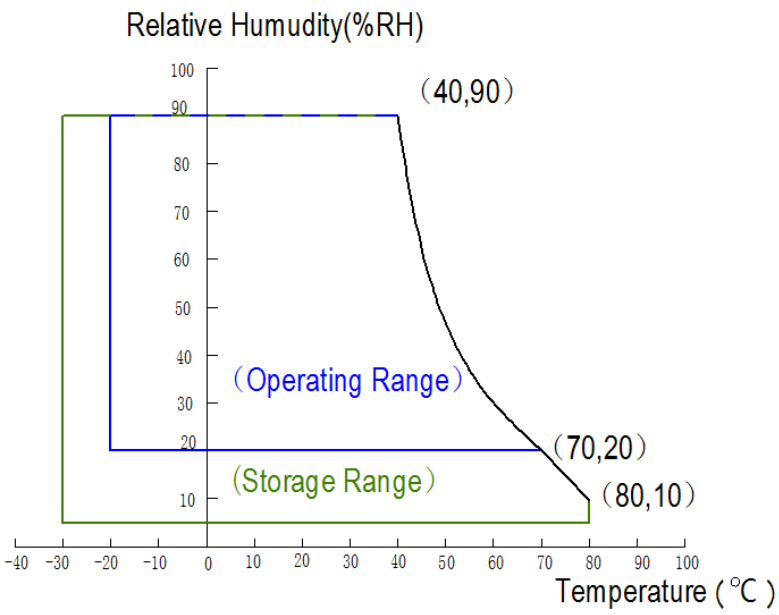

3.0 ELECTRICAL SPECIFICATIONS

3.1 TFT LCD Module

[Ta = 25 ± 2 °C]

< Table 3. LCD Module Electrical specifications >

Parameter	Symbol	Values			Unit	Notes
		Min.	Typ.	Max.		
Power Supply Voltage	VDD	3.0	3.3	3.6	V	Note 1
Power Supply Current	IDD	150	180	200	mA	
BLU Supply Voltage	V _{BLU}	10.8	12	13.2	V	
BLU Supply Current	I _{BLU}	-		620	mA	
Power Consumption	P _D	0.495	0.594	0.66	W	Note 2
	P _{BLU}	-	-	7.45	W	
	P _{total}	-	-	8.11	W	

- Notes : 1. The supply voltage is measured and specified at the interface connector of LCM.
 The current draw and power consumption specified is for VDD=3.3V, Frame rate f_v=60Hz and Clock frequency = 72.4MHz. Test Pattern of power supply current
- a) Typ : Mosaic 8 x 6 Pattern(L0/L255) b) Max : skip subPixel(L255)

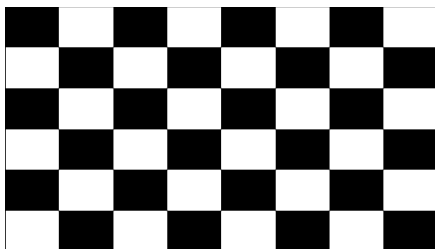

2. The duration of rush current is about 2ms and rising time of Power Input is 1ms(min)

3.2 Back-Light Unit**Table 4. LED Bar Electrical Specifications >**

[Ta =25±2 °C]

Parameter	Symbol	Values			Unit	Notes
		Min.	Typ.	Max.		
LED Supply Voltage	V_{LED}	-	38.4	39.6	V	
LED Supply Current	I_{LED}	-	160	-	mA	Note 1
Power Consumption	P_{LED}	-	6.14	6.34	W	
LED Quantity	QLED	-	48	-	EA	
LED Life Time	TLED	50000	-	-	Hrs	Note 2/3

Notes: 1. LED Bar:4Parallel*12String) , $I_{LED}=40mA*4=160mA$

$$P_{LED} = V_{LED} \times I_{LED} \text{ (Without LED converter transfer efficiency)}$$

- The life time of LED, 50,000Hrs, is determined as the time at which luminance of the LED is 50% compared to that of initial value at the typical LED current on condition of continuous operating at $25 \pm 2^{\circ}C$.
- Only under the above operating conditions could the life time of LED be guaranteed.

3.3 INPUT TERMINAL PIN ASSIGNMENT

This LCD employs two interface connections, a 20 pin connector is used for the LCD module electronics interface and a 6 pin connector is used for the backlight unit.

3.3.1 Pin assignment for LCD module

Connector : DF19G-20P-1H (HRS) or equivalent

< Table5. Pin Assignment for LCD Module Connector >

Pin No.	Symbol	Description	I/O
1	VCC	Power supply	P
2	VCC		P
3	HFRC_EN	6/8bit select	I
4	GND	Ground	-
5	D0-	Pixel data	I
6	D0+		I
7	GND	Ground	-
8	D1-	Pixel data	I
9	D1+		I
10	GND	Ground	-
11	D2-	Pixel data	I
12	D2+		I
13	GND	Ground	-
14	CLK-	Pixel data	I
15	CLK+		I
16	GND	Ground	-
17	SDA	Not connect	-
18	SCL	Not connect	-
19	D3-	Pixel data	I
20	D3+		I

3.3.2 Pin assignment for BLU

Connector : MSA24038P6 (STM) or equivalent

< Table6. Pin assignment for BLU >

Pin No	Symbol	Description	Remarks
1	PWM	Luminance control	
2	BRTC	Backlight ON/OFF control	High or Open : Backlight ON Low : Backlight OFF
3	GND	Ground	
4	GND	Ground	
5	VDD	Power supply	
6	VDD	Power supply	

3.4 DC Specification

< Table7. DC Specification >

Parameter	Symbol	Min	Typ	Max	Unit	Condition
Supply current	I_{DD}	150	180	200	mA	
LVDS DC specifications						
Differential input high threshold	V_{TH}	-	-	+100	mV	$V_{IC}=1.2V$
Differential input low threshold	V_{TL}	-100	-	-	mV	
LVDS common mode voltage	V_{IC}	0.7	-	1.6	V	
LVDS swing voltage	V_{ID}	± 100	-	± 600	mV	

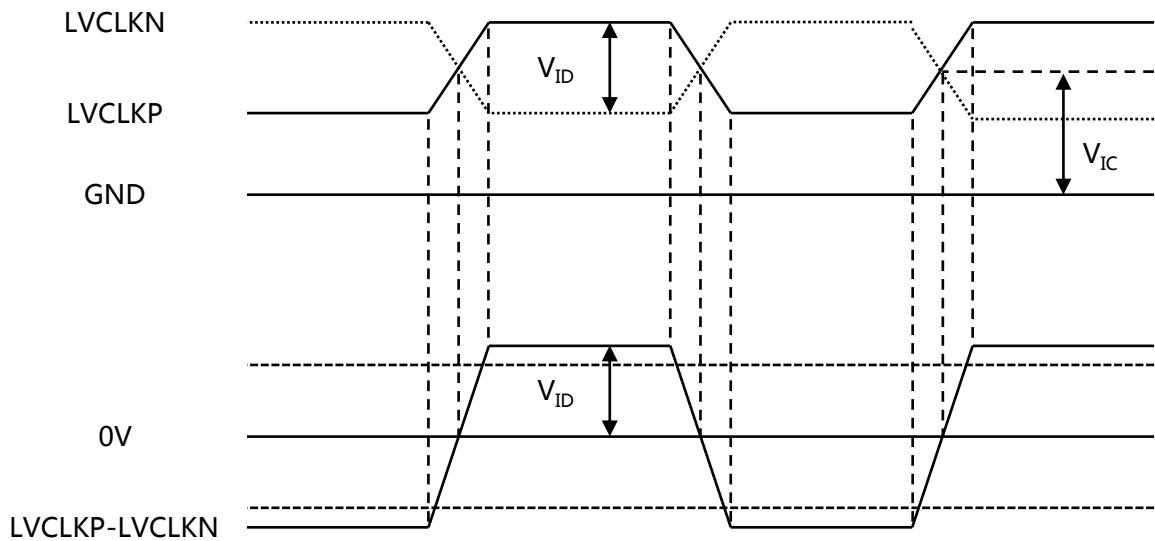

< LVDS V_{ID} and V_{IC} definition >

3.5 AC Specification

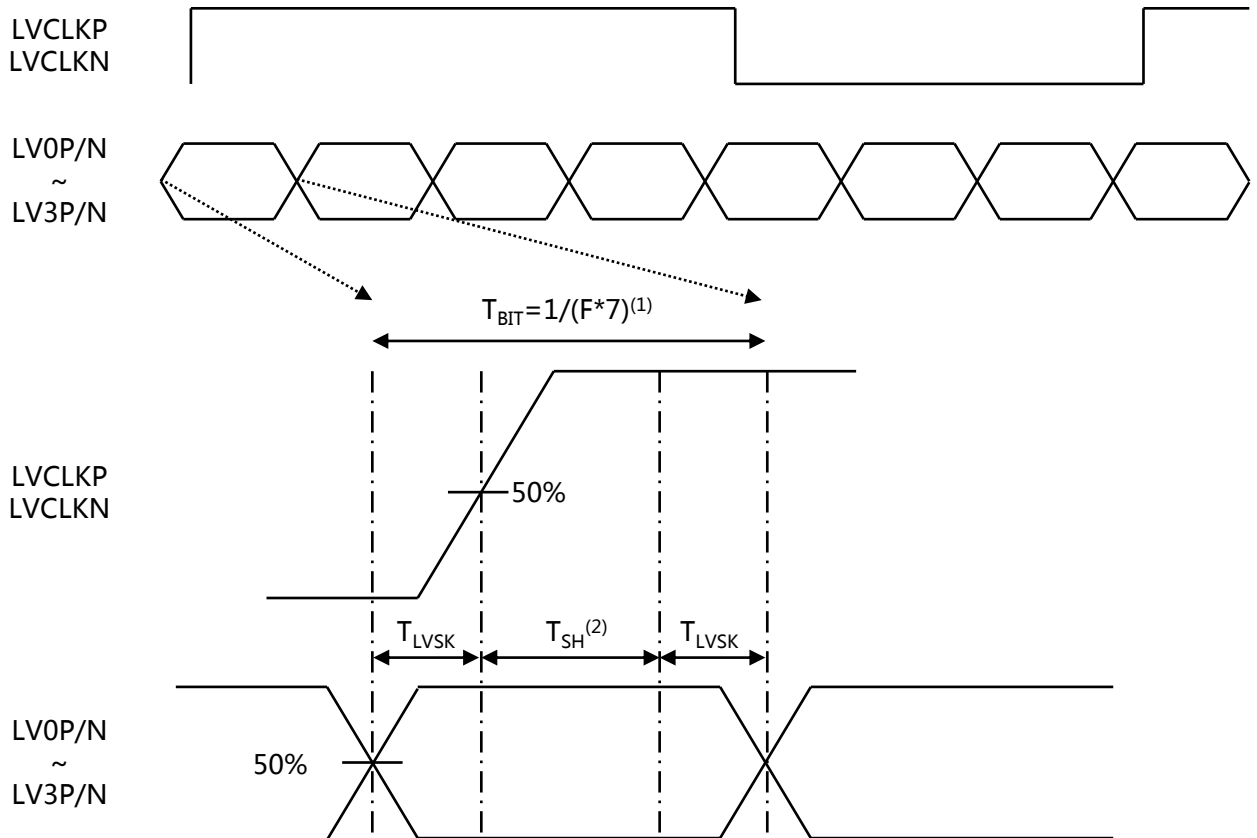

Note:

- (1) T_{BIT} : Data period
- (2) Internal CLK sampling data window

< LVDS channel to channel skew >

< Table8. AC Specification >

Description	Symbol	Condition	Min	Typ	Max	Unit
LVDS Input frequency	F	-	20	-	85	MHz
LVDS channel to channel skew	T_{LVSK}	F=65MHz $V_{IC}=1.2V$ $V_{ID}=\pm 200mV$	-600	-	+600	ps

3.6 Interface timing Parameter

< Table9. Timing Parameter >

Item		Symbol	min	typ	max	UNIT	
LCD	Frame Rate	-	58	60	62	Hz	
	Pixels Rate	-	66.3	72.4	78.9	MHz	
Timing	Horizontal	Horizontal total time	tHP	1380	1440	1500	t _{CLK}
		Horizontal Active time	tHadr	800			t _{CLK}
		Horizontal Back Porch	tHBP	-	80	-	t _{CLK}
		Horizontal Front Porch	tHFP	-	80	-	t _{CLK}
	Vertical	Vertical total time	tvp	824	838	872	t _H
		Vertical Active time	tVadr	800			t _H
		Vertical Back Porch	tVBP	-	14	-	t _H
		Vertical Front Porch	tVFP	-	9	-	t _H
Lane			-	1	-	Lane	

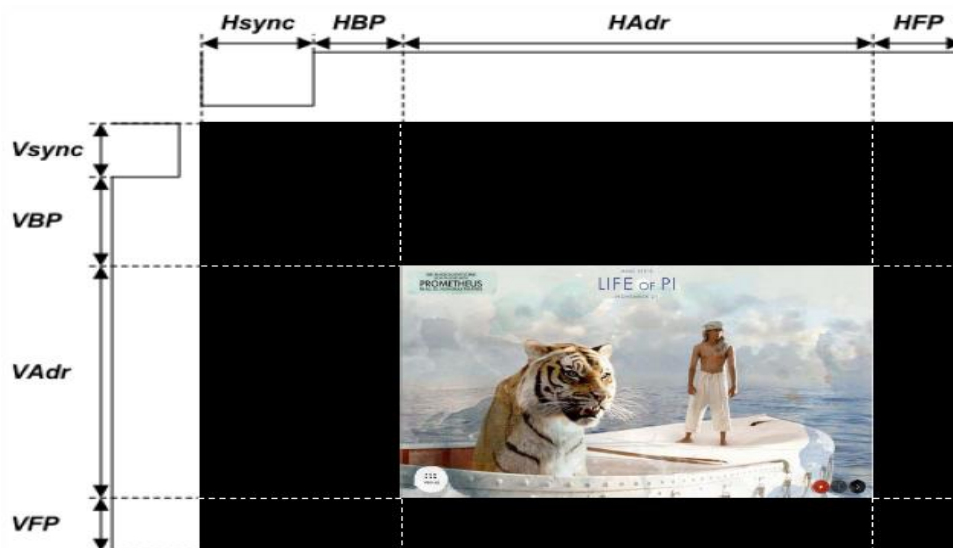

3.7 Power Sequence

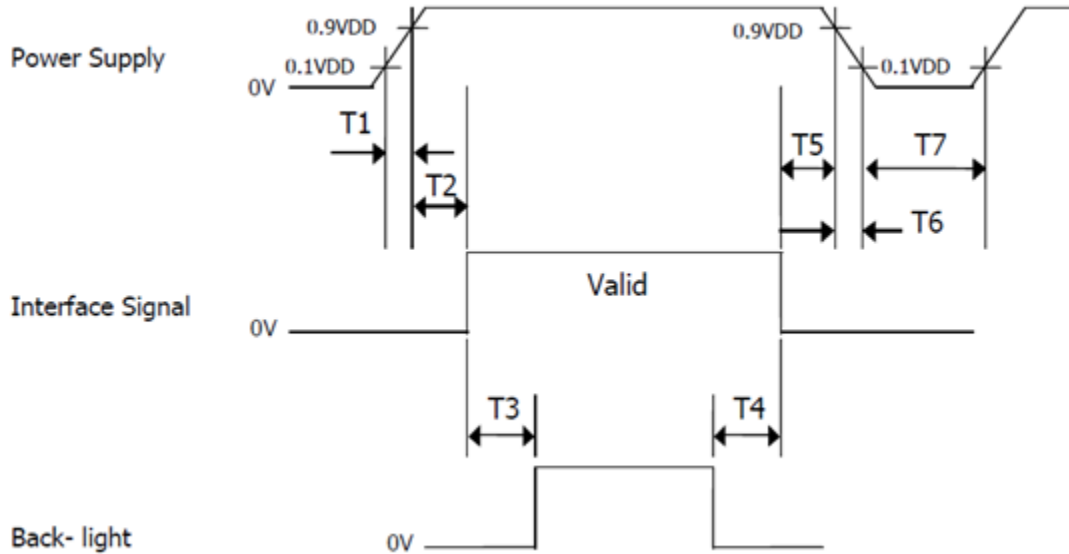

< Table10. Sequence Table >

Parameter	Value			Units
	Min.	Typ.	Max.	
T1	0	-	10	(ms)
T2	0	-	50	(ms)
T3	200	-	-	(ms)
T4	200	-	-	(ms)
T5	0	-	50	(ms)
T6	0	-	10	(ms)
T7	500	-	-	(ms)

3.8 Input Color Data Mapping

< Table11. Input Signal and Display Color Table >

Color & Gray Scale		Input Data Signal																							
		Red Data								Green Data				Blue Data											
		R7	R6	R5	R4	R3	R2	R1	R0	G7	G6	G5	G4	G3	G2	G1	G0	B7	B6	B5	B4	B3	B2	B1	B0
Basic Colors	Black	0	0	0	0	0	0	0	0	0	0	0	0	0	0	0	0	0	0	0	0	0	0	0	
	Blue	0	0	0	0	0	0	0	0	0	0	0	0	0	0	0	0	1	1	1	1	1	1	1	1
	Green	0	0	0	0	0	0	0	0	1	1	1	1	1	1	1	1	0	0	0	0	0	0	0	0
	Cyan	0	0	0	0	0	0	0	0	1	1	1	1	1	1	1	1	1	1	1	1	1	1	1	1
	Red	1	1	1	1	1	1	1	1	0	0	0	0	0	0	0	0	0	0	0	0	0	0	0	0
	Magenta	1	1	1	1	1	1	1	1	0	0	0	0	0	0	0	0	1	1	1	1	1	1	1	1
	Yellow	1	1	1	1	1	1	1	1	1	1	1	1	1	1	1	1	0	0	0	0	0	0	0	0
	White	1	1	1	1	1	1	1	1	1	1	1	1	1	1	1	1	1	1	1	1	1	1	1	1
Gray Scale of Red	Black	0	0	0	0	0	0	0	0	0	0	0	0	0	0	0	0	0	0	0	0	0	0	0	
	△	0	0	0	0	0	0	0	1	0	0	0	0	0	0	0	0	0	0	0	0	0	0	0	
	Darker	0	0	0	0	0	0	1	0	0	0	0	0	0	0	0	0	0	0	0	0	0	0	0	
	△	↑								↑				↑											
	▽	↓								↓				↓											
	Brighter	1	1	1	1	1	1	0	1	0	0	0	0	0	0	0	0	0	0	0	0	0	0	0	0
	▽	1	1	1	1	1	1	1	0	0	0	0	0	0	0	0	0	0	0	0	0	0	0	0	0
	Red	1	1	1	1	1	1	1	1	0	0	0	0	0	0	0	0	0	0	0	0	0	0	0	0
Gray Scale of Green	Black	0	0	0	0	0	0	0	0	0	0	0	0	0	0	0	0	0	0	0	0	0	0	0	
	△	0	0	0	0	0	0	0	0	0	0	0	0	0	0	0	1	0	0	0	0	0	0	0	
	Darker	0	0	0	0	0	0	0	0	0	0	0	0	0	0	1	0	0	0	0	0	0	0	0	
	△	↑								↑				↑											
	▽	↓								↓				↓											
	Brighter	0	0	0	0	0	0	0	0	1	1	1	1	1	1	0	1	0	0	0	0	0	0	0	0
	▽	0	0	0	0	0	0	0	0	1	1	1	1	1	1	1	0	0	0	0	0	0	0	0	0
	Green	0	0	0	0	0	0	0	0	1	1	1	1	1	1	1	1	0	0	0	0	0	0	0	0
Gray Scale of Blue	Black	0	0	0	0	0	0	0	0	0	0	0	0	0	0	0	0	0	0	0	0	0	0	0	
	△	0	0	0	0	0	0	0	0	0	0	0	0	0	0	0	0	0	0	0	0	0	0	1	
	Darker	0	0	0	0	0	0	0	0	0	0	0	0	0	0	0	0	0	0	0	0	0	0	1	0
	△	↑								↑				↑											
	▽	↓								↓				↓											
	Brighter	0	0	0	0	0	0	0	0	0	0	0	0	0	0	0	0	1	1	1	1	1	1	0	1
	▽	0	0	0	0	0	0	0	0	0	0	0	0	0	0	0	0	1	1	1	1	1	1	1	0
	Blue	0	0	0	0	0	0	0	0	0	0	0	0	0	0	0	0	1	1	1	1	1	1	1	1
Gray Scale of White	Black	0	0	0	0	0	0	0	0	0	0	0	0	0	0	0	0	0	0	0	0	0	0	0	
	△	0	0	0	0	0	0	0	1	0	0	0	0	0	0	0	1	0	0	0	0	0	0	1	
	Darker	0	0	0	0	0	0	1	0	0	0	0	0	0	0	1	0	0	0	0	0	0	0	1	0
	△	↑								↑				↑											
	▽	↓								↓				↓											
	Brighter	1	1	1	1	1	1	0	1	1	1	1	1	1	0	1	1	1	1	1	1	1	0	1	1
	▽	1	1	1	1	1	1	1	0	1	1	1	1	1	1	1	0	1	1	1	1	1	1	1	0
	White	1	1	1	1	1	1	1	1	1	1	1	1	1	1	1	1	1	1	1	1	1	1	1	1

3.9 Input Color Data Mapping

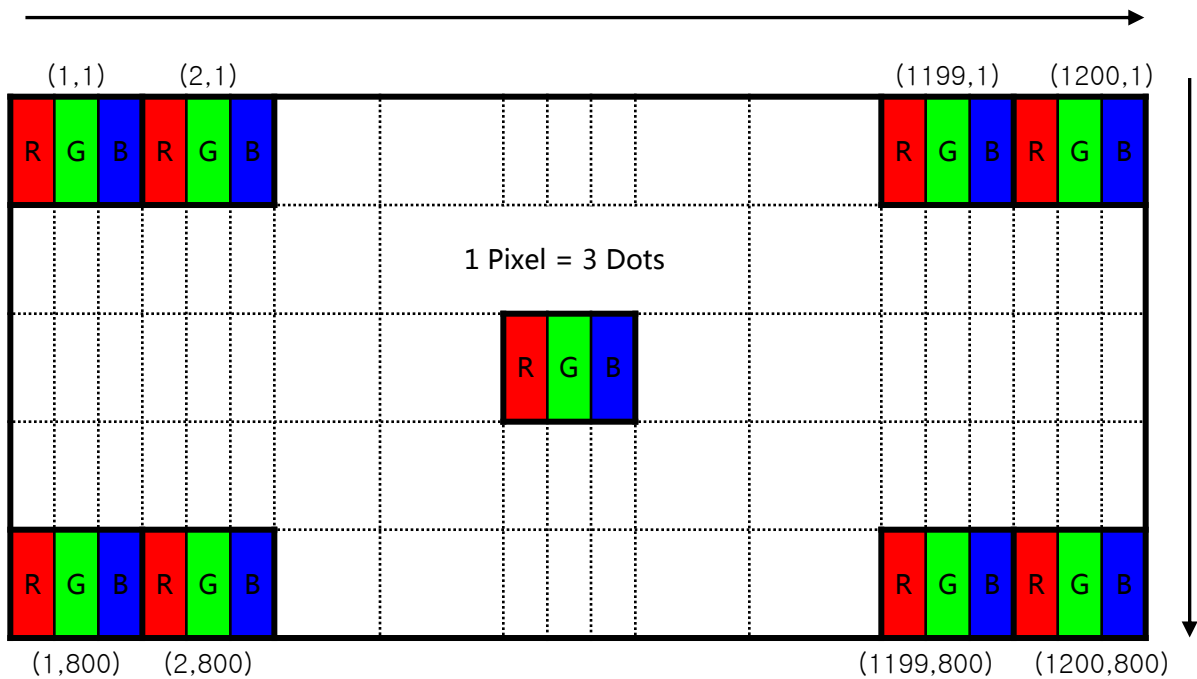

Display Position of Input Data (V-H)

4.0 OPTICAL SPECIFICATIONS

4.1 Overview

The test of optical specifications shall be measured in a dark room (ambient luminance ≤ 1 lux and temperature = $25 \pm 2^\circ\text{C}$) with the equipment of Luminance meter system (Gonio meter system and TOPCON BM-5) and test unit shall be located at an approximate distance 50cm from the LCD surface at a viewing angle of θ and Φ equal to 0° . We refer to $\theta\emptyset=0$ ($=\theta 3$) as the 3 o' clock direction (the "right"), $\theta\emptyset=90$ ($=\theta 12$) as the 12 O' clock direction ("upward"), $\theta\emptyset=180$ ($=\theta 9$) as the 9 O' clock direction ("left") and $\theta\emptyset=270$ ($=\theta 6$) as the 6 O' clock direction ("bottom"). While scanning θ and/or \emptyset , the center of the measuring spot on the Display surface shall stay fixed.

4.2 Optical Specifications

< Table11. Optical Table >

Item	Symbol	Condition	Min	Typ.	Max	Unit	Note
luminance	Bp	$\theta=0^\circ$	400	500	--	cd/m ²	Note 1
Brightness Uniformity	ΔBp		70	80	--	%	Note 2
Viewing Angle	θ_L	Cr ≥ 10	80	85	--	deg	Note 3
	θ_R		80	85	--		
	ψ_T		80	85	--		
	ψ_B		80	85	--		
Contrast Ratio	Cr	$\theta=0^\circ$	1000	1200		-	Note 4
Response Time	Tr+Tf	FF= 0°	-	30	35	ms	Note 5
Color Coordinate of CIE1931	Rx	$\theta=0^\circ$	0.618	0.648	0.678	-	Note 6
	Ry		0.298	0.328	0.358		
	Gx		0.26	0.29	0.32		
	Gy		0.59	0.62	0.65		
	Bx		0.121	0.151	0.181		
	By		0.025	0.055	0.085		
	Wx		0.283	0.313	0.343		
	Wy		0.299	0.329	0.359		
NTSC Ratio	NTSC	CIE1931	68	72	--	%	Note 7
Polarization Direction of Front Polarizer	PdF		--	0°	--	deg	Note 8
Polarization Direction of Rear Polarizer	PdR		--	90°	--	Deg	

Note1:Luminance measurement

The test condition is at ILED=160mA and measured on the surface of LCD module at 25°C.

- The data are measured after LEDs are lighted on for more than 5 minutes and LCM displays are fully white. The brightness is the center of the LCD. Measurement equipment CS2000 or similar equipments (Field of view:1deg,Distance:50cm)
- Measuring surroundings: Dark room.
- Measuring temperature: Ta=25°C.
- Adjust operating voltage to get optimum contrast at the center of the display.
- Measured value at the center point of LCD panel must be after more than 5 minutes while backlight turning on.

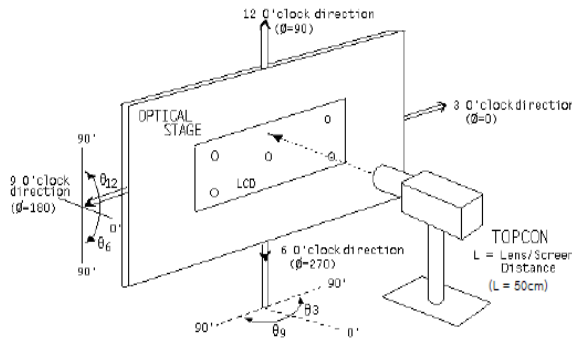

Note2:Uniformity

- The test condition is at ILED=160mA and measured on the surface of LCD module at 25°C.
- Measurement equipment:CS2000 or similar equipments
- The luminance uniformity is calculated by using following formula:
 $\Delta Bp = Bp (\text{Min.}) / Bp (\text{Max.}) \times 100 (\%)$
- ΔBp = $Bp (\text{Min.}) / Bp (\text{Max.}) \times 100 (\%)$
- $Bp (\text{Max.})$ = Maximum brightness in 9 measured spots
- $Bp (\text{Min.})$ = Minimum brightness in 9 measured spots.

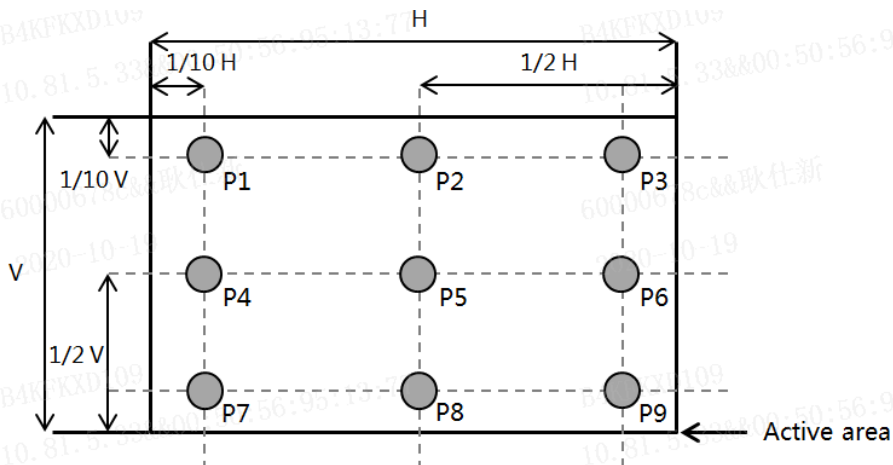

Note 3: The definition of Viewing Angle

Refer to the graph below marked by θ and ϕ .

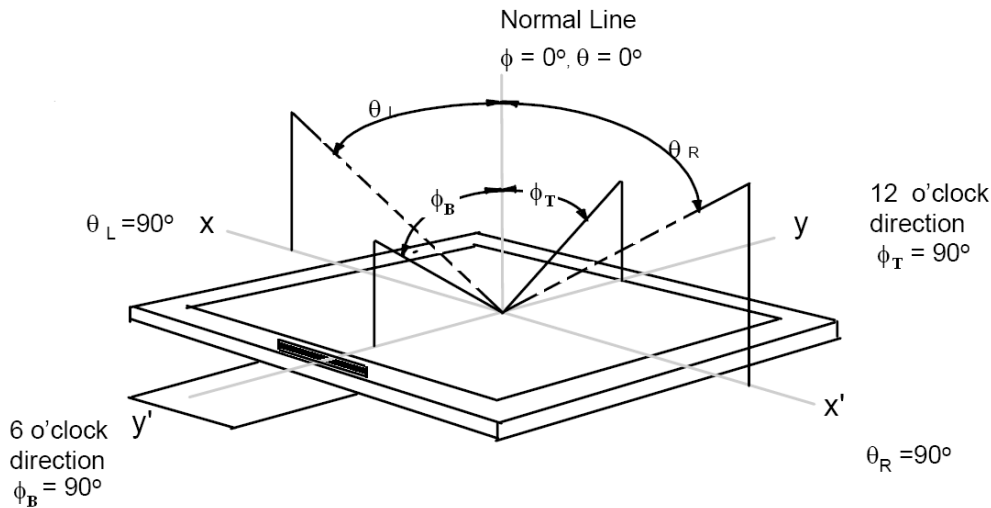

Note 4: The definition of Contrast Ratio (Test LCM using CS2000 or similar equipments):

$$\text{Contrast Ratio (CR)} = \frac{\text{Luminance When LCD is at "White" state}}{\text{Luminance When LCD is at "Black" state}}$$

(Contrast Ratio is measured in optimum common electrode voltage)

Note 5: Definition of Response time. (Test LCD using DMS501 or similar equipments):

The output sign also photo detector are measured when the input sign also are changed from "black" to "white" (Voltage falling time) and from "white" to "black" (Voltage rising time), respectively. The response time is defined as the time interval between the 10% and 90% of amplitudes. Refer to figures below.

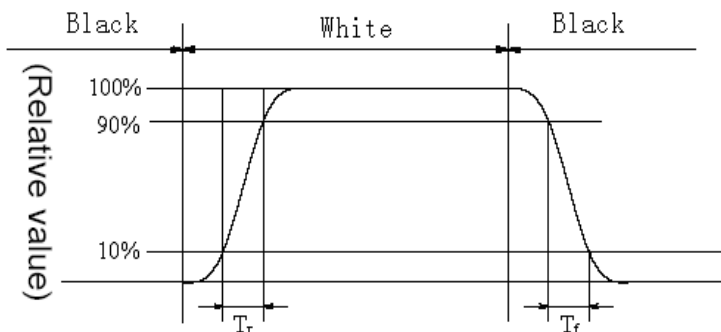

	L0	L1	L2	L3	L4	L5	L6	L7
L0								
L1								
L2								
L3								
L4								
L5								
L6								
L7								

Response time of gray to gray:

Measurement equipment: DMS501 or similar equipments.

Test method: we define 8 grays L0-L7, the grays of L0-L7 were defined as: 0, 36, 73, 109, 146, 182, 219, 255. The output signals of photodetector are measured when the input signals are changed from "Lx" to "Ly", x, y = [0, 7]. The response time is defined as the time interval between the 10% and 90% of amplitudes. The result of the test can be noted as below:

PRODUCT GROUP		REV	ISSUE DATE	BOE
TFT- LCD PRODUCT		P0	2020-11-15	
SPEC. NUMBER	SPEC. TITLE			PAGE
S8-*	B3 EV121WXM-N12 Product Specification			20 OF 33

Note 6: Color Coordinates of CIE 1931

The test condition is at ILED=160mA and measured on the surface of LCD module at 25°C.

Measurement equipment:CS2000 or similar equipments

The Color Coordinate (CIE 1931) is the measurement of the center of the display shown in below figure.

Note 7: Definition of Color of CIE Coordinate and NTSC Ratio.

$$S = \frac{\text{area of RGB triangle}}{\text{area of NTSC triangle}} \times 100\%$$

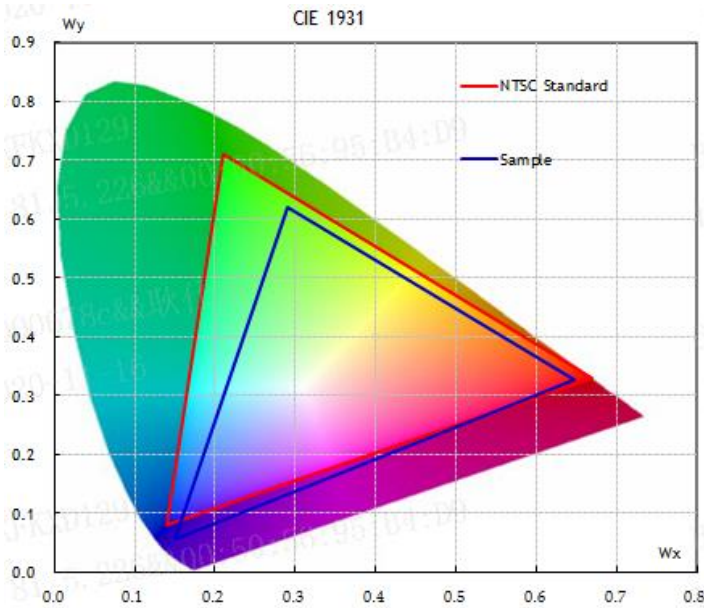

Note 8: Polarization Direction Definition

- Viewing direction is normal user viewing direction which is vertical to the display surface
- The polarizer which is closer to viewer is defined as Front Polarizer
- The polarizer which is on the rear side of viewer is defined as Rear Polarizer
- The X axis is defined as parallel line to top & bottom sidelines of the Active Area
- PdF which is marked in blue arrow is polarization degree of Front polarizer
- PdR which is marked in red arrow is polarization degree of Back polarizer
- The polarization degree parameter must be indicated in range of 0deg to 180deg according to above definition

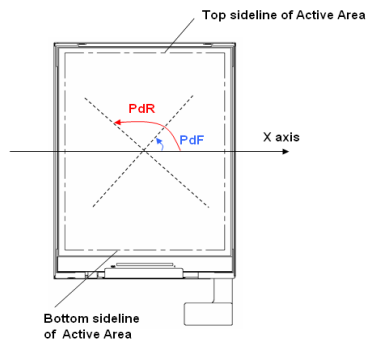

Note 9: Definition of gray inversion angle

- Refer to the graph of note 9.
- Using luminance test method.
- Test pattern : 128 gray
- If the viewing direction is 12 o' clock ,then test the luminance while $\theta = -60^\circ, \theta = -50^\circ, \theta = -40^\circ, \theta = -30^\circ, \theta = -20^\circ, \theta = -10^\circ, \theta = 0^\circ, \theta = 10^\circ, \theta = 20^\circ, \theta = 30^\circ, \theta = 40^\circ, \theta = -50^\circ, \theta = 60^\circ$. The luminance test as figure below:

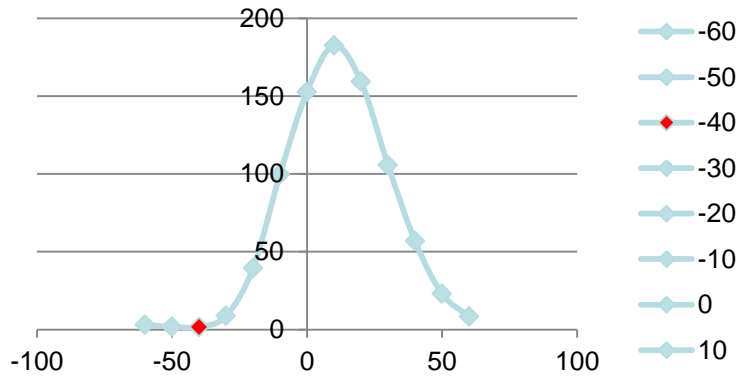

5.0 RELIABILITY TEST

The Reliability test items and its conditions are shown in below.

<Table 12. Reliability Test Parameters >

No	Test Items	Conditions
1	HAST	110°C、85%RH、0.122Mpa , 8hr
2	High temperature & high humidity (storage test)	60°C , 90%RH , 240hr
3	High temperature storage test	80°C , 240hr
4	Low temperature storage test	-30°C , 240hr
5	High temperature & high humidity (operation test)	60°C , 90%RH , 240hr
6	Low temperature operation test	-20°C , 240hr
7	High temperature operation test	70°C , 240hr
8	Thermal Shock Test	-40°C~85°C , 1hr/cycle , 100cycle
9	PCT	121°C , 100%RH , 2atm , 12hr
10	ESD	150pF , 330Ω , ±8kV(Contact) , ±15kV (Air) Class B : 允许可以自动恢复的偶发性息屏或 功能异常
11	Packing VIB	1.47G , 1-200hz , X , Y , ±Z , 30min/Axis

6.0 PACKING INFORMATION(产品形态 : LCM)

Packing procedure:

将1pcs LCM放入Tray中 (Panel朝上) , 然后在LCM上放置
1pcs EPE Spacer
容量 : 1pcs EPE Spacer/Tray
1pcs LCM/Tray

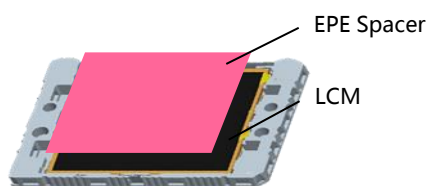

Step 1

堆叠放置15pcs Tray (不旋转堆叠) , 顶部再放置1pcs 空
Tray , 然后将16pcs Tray 平放入Shielding Bag并抽真空
(注意真空不要过紧, 避免Tray变形挤压产品)

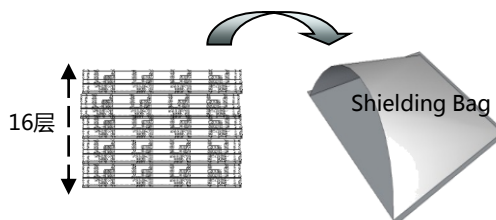

Step 2

在Inner Box放置1pcs EPE Cover , 将堆叠好的16pcs Tray
平放入Box , 再放置1pcs EPE Cover , 对Box进行封箱, 并粘
贴Box标签
容量 : 15pcs LCM/Box

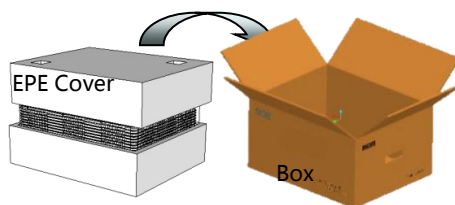

Step 3

每个Pallet上放3层Box , 1层8箱 , 共计24箱 , Pallet外进行
打包带、缠膜包装
容量 : 24pcs Box/Pallet
360pcs LCM/Pallet



Step 4

6.1 Packing Note(产品形态 : LCM)

- Box Dimension: 375mm(W) x 280mm(D) x 290mm(H)
- Package Quantity in one Box: 15pcs

PRODUCT GROUP		REV	ISSUE DATE	BOE
TFT- LCD PRODUCT		P0	2020-11-15	
SPEC. NUMBER	SPEC. TITLE			PAGE
S8-*	B3 EV121WXM-N12 Product Specification			24 OF 33

6.2 Box label (产品形态 : LCM)

- Label Size :115mm*55mm
- Contents
 - Model : First 12 digits of FG-Code: EV121WXM-N12
 - Q`ty : 15pcs/Box
 - Serial No. : Box Serial No. as shown below.
 - Date : Packing Date
 - FG Code : Last 4 digits of FG-Code

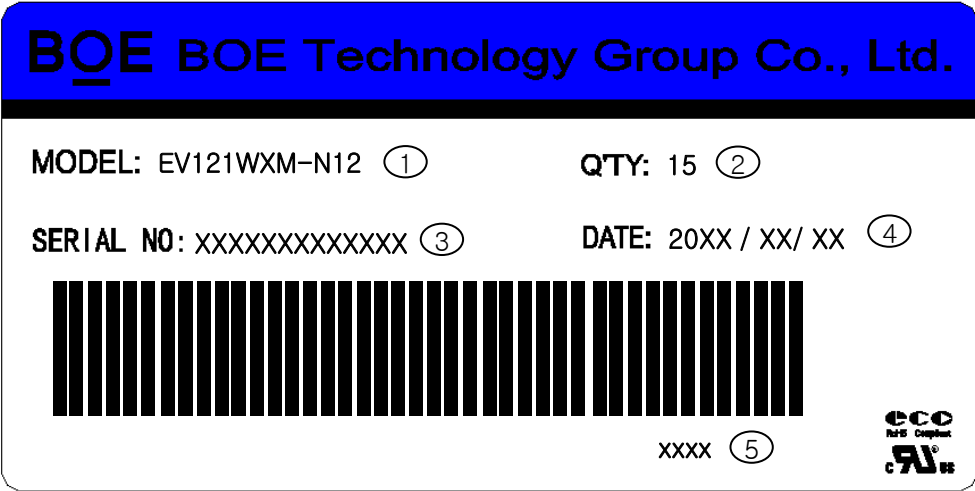

No.	1	2	3	4	5	6	7	8	9	10	11	12	13
Code	X	X	S	3	2	0	9	0	0	0	0	0	1
Description	GBN		Grade	B3	Year		Month	Rev	Serial number				

PRODUCT GROUP		REV	ISSUE DATE	BOE
TFT- LCD PRODUCT		P0	2020-11-15	
SPEC. NUMBER	SPEC. TITLE			PAGE
S8-*	B3 EV121WXM-N12 Product Specification			25 OF 33

7.0 Product Label



Label Size: 48mmx12mmx0.075mm, 44-9231007

1. FG-CODE: EV121WXM-N12
2. MDL ID
3. MDL ID对应条形码

BOE MDL ID rule

序列号	1	2	3	4	5	6	7	8	9	10	11	12	13	14	15	16	17
代码	X	X	X	3	X	X	X	3	G	P	0	X	X	X	X	X	X
描述	GBN代码		等级	B3	年	月	日	FG Code后四位				序列号					

PRODUCT GROUP		REV	ISSUE DATE	BOE
TFT- LCD PRODUCT		P0	2020-11-15	
SPEC. NUMBER	SPEC. TITLE			PAGE
S8-*	B3 EV121WXM-N12 Product Specification			26 OF 33

8.0 Handling & Cautions

Please pay attention to the followings when you use this TFT LCD Module.

8.1 Mounting Precautions

- Use finger-stalls with soft gloves in order to keep display clean during the incoming inspection and assembly process.
- You must mount a module using specified mounting holes (Details refer to the drawings).
- You should consider the mounting structure so that uneven force (ex. Twisted stress, Concentrated stress) is not applied to the module. And the case on which a module is mounted should have sufficient strength so that external force is not transmitted directly to the module.
- Do not apply mechanical stress or static pressure on module; Abnormal display cause by pressing some parts of module during assembly process, do not belong to product failure, the press should be agreed by two sides.
- Determine the optimum mounting angle, refer to the viewing angle range in the specification for each model.
- Do not apply mechanical stress or static pressure on module, and avoid impact, vibration and falling.
- Acetic acid type and chlorine type materials for the cover case are not desirable because the former generates corrosive gas of attacking the polarizer at high temperature and the latter causes circuit break by electro-chemical reaction.
- Protection film for polarizer on the module should be slowly peeled off before display.
- Be careful to prevent water & chemicals contact the module surface.
- You should adopt radiation structure to satisfy the temperature specification.
- Do not touch, push or rub the exposed polarizers with glass, tweezers or anything harder than HB pencil lead. And please do not rub with dust clothes with chemical treatment.

Do not touch the surface of polarizer for bare hand or greasy cloth.(Some cosmetics are detrimental to the polarizer.)

PRODUCT GROUP		REV	ISSUE DATE	BOE
TFT- LCD PRODUCT		P0	2020-11-15	
SPEC. NUMBER	SPEC. TITLE			PAGE
S8-*	B3 EV121WXM-N12 Product Specification			27 OF 33

- When the surface becomes dusty, please wipe gently with absorbent cotton or other soft materials like chamois soaks with petroleum benzine. Normal-hexane & alcohol is recommended for cleaning the adhesives used to attach front / rear polarizers. Do not use acetone, toluene , because they cause chemical damage to the polarizer.
- Wipe off saliva or water drops as soon as possible. Their long time contact with polarizer causes deformations and color fading.
- This module has its circuitry PCB' s on the rear side and Driver IC, should be handled carefully in order not to be stressed.
- Avoid impose stress on PCB and Driver IC during assembly process ,Do not drawing, bending, COF package & wire.
- Do not disassemble the module.

8.2 Operating Precautions

- Do not connector or disconnect the cable to/from the Module at the "Power On" Condition.
- When the module is operating, do not lose CLK, ENAB signals. If any one of these signals is lost, the module would be damaged.
- Obey the supply voltage sequence. If wrong sequence is applied, the module would be damaged.
- Do not allow to adjust the adjustable resistance or switch.
- The electrochemical reaction caused by DC voltage will lead to LCD module degradation, so DC drive should be avoided.
- The LCD modules use C-MOS LSI drivers, so customers are recommended that any unused input terminal would be connected to Vdd or Vss, do not input any signals before power is turn on, and ground you body, work/assembly area, assembly equipment to protect against static electricity.
- Do not exceed the absolute maximum rating value. (supply voltage variation, input voltage variation, variation in part contents and environmental temperature, and so on) Otherwise the Module may be damaged.
- Module has high frequency circuits. Sufficient suppression to the electromagnetic interference shall be done by system manufacturers. Grounding and shielding methods may be important to minimized the interference.

PRODUCT GROUP		REV	ISSUE DATE	BOE
TFT- LCD PRODUCT		P0	2020-11-15	
SPEC. NUMBER	SPEC. TITLE			PAGE
S8-*	B3 EV121WXM-N12 Product Specification			28 OF 33

- The cables should be as short as possible between System Board and PCB interface.
- Connectors are precision devices to transmit electrical signals, and operators should plug in parallel.
- Be careful for condensation at sudden temperature change. Condensation makes damage to polarizer or electrical contacted parts. And after fading condensation, smear or spot will occur.

8.3 Electrostatic Discharge Precautions

- Avoid the use work clothing made of synthetic fibers. We recommend cotton clothing or other conductivity-treated fibers.
- Since a module is composed of electronic circuits, it is not strong to electrostatic discharge. Make certain that treatment persons are connected to ground through wrist band etc.
- Do not close to static electricity to avoid product damage.
- Do not touch interface pin directly.

8.4 Precautions for Strong Light Exposure

- Do not leave the module operation or storage in Strong light . Strong light exposure causes degradation of polarizer and color filter.

8.5 Precautions for Storage

A. Atmosphere Requirement

ITEM	UNIT	MIN	MAX
Storage Temperature	(°C)	5	40
Storage Humidity	(%rH)	40	75
Storage Life	6 months		
Storage Condition	<ul style="list-style-type: none"> • The storage room should be equipped with a dark and good ventilation facility. • Prevent products from being exposed to the direct sunlight, moisture and water. • The product need to keep away from organic solvent and corrosive gas. • Be careful for condensation at sudden temperature change. • Storage condition is guaranteed under packing conditions. 		

B. Package Requirement

- The product should be placed in a sealed polythene bag.
- Product Should be placed on the pallet, Which is away from the floor, Be cautions not to pile the product up.
- The polarizer surface should not come in contact with any other object. It is recommended that they be stored in the container in which they were shipped.
- As the original protective film, do not use the adhesive protective film to avoid change of Pol color and characteristic.

8.6 Precautions for protection film

- Remove the protective film slowly, keeping the removing direction approximate 30-degree not vertical from panel surface, If possible, under ESD control device like ion blower, and the humidity of working room should be kept over 50%RH to reduce the risk of static charge.
- People who peeled off the protection film should wear anti-static strap and grounded well.

PRODUCT GROUP		REV	ISSUE DATE	BOE
TFT- LCD PRODUCT		P0	2020-11-15	
SPEC. NUMBER	SPEC. TITLE			PAGE
S8-*	B3 EV121WXM-N12 Product Specification			30 OF 33

8.7 Appropriate Condition for Commercial Display

-Generally large-sized LCD modules are designed for consumer applications . Accordingly, long-term display like in Commercial Display application, can cause uneven display including image sticking. To optimize module's lifetime and function, several operating usages are required.

1. Normal operating condition

- Temperature: 20±15°C
- Operating Ambient Humidity : 55±20%
- Display pattern: dynamic pattern (Real display)
- Well-ventilated place is recommended to set up Commercial Display system

2. Special operating condition

a. Ambient condition

- Well-ventilated place is recommended to set up Commercial Display system.

b. Power and screen save

- Periodical power-off or screen save is needed after long-term display.

c. As the low temperature, the response time is greatly delayed. As the high temperatures (higher than the operating temperature) the LCD module may turn black screen. The above phenomenon cannot explain the failure of the display. When the temperature returns to the normal operating temperature, the LCD module will return to normal display.

d. When expose to drastic fluctuation of temperature (hot to cold or cold to hot) ,the LCD module may be affected; Specifically, drastic temperature fluctuation from cold to hot ,produces dew on the LCD module 's surface which may affect the operation of the polarizer and LCD module .

e. Do not exceed the absolute maximum rating value. (supply voltage variation, input v oltage variation, variation in part contents and environmental temperature, and so on) Otherwise the Module may be damaged.

f. Product reliability and functions are only guaranteed when the product is used under right operation usages. If product will be used in extreme conditions such as high temperature, high humidity, high altitude, special display images, running time, long time operation, outdoor operation, etc. It is strongly recommended to contact BOE for filed application engineering advice. Otherwise, its reliability and function may not be guaranteed. Extreme conditions are commonly found at airports, transit stations, banks, stock market and controlling systems.

PRODUCT GROUP		REV	ISSUE DATE	BOE
TFT- LCD PRODUCT		P0	2020-11-15	
SPEC. NUMBER	SPEC. TITLE			PAGE
S8-*	B3 EV121WXM-N12 Product Specification			31 OF 33

3. Operating usages to protect against image sticking due to long-term static display.
 - a. Suitable operating time: under 20 hours a day.
 - b. Static information display recommended to use with moving image.
 - Cycling display between 5 minutes' information(static) display and 10 seconds' moving image.
 - c. Background and character (image) color change
 - Use different colors for background and character, respectively.
 - Change colors themselves periodically.
 - d. Avoid combination of background and character with large different luminance.
 - 1) Abnormal condition just means conditions except normal condition.
 - 2) Black image or moving image is strongly recommended as a screen save
4. Lifetime in this spec. is guaranteed only when Commercial Display is used according to operating usages.

8.8 Other Precautions

A. LC Leak

- If the liquid crystal material leaks from the panel, it is recommended to wash the LC with acetone or ethanol and then burn it.
- If the liquid crystal material leaks from the panel, it should be kept away from the eyes or mouth. In case of contact with hands, skin or clothes, it has to be washed away thoroughly with soap.
- If LC in mouth, mouth need to be washed, drink plenty of water to induce vomiting and follow medical advice.
- If LC touch eyes, eyes need to be washed with running water at least 15 minutes.

B. Rework

- When returning the module for repair or etc., Please pack the module not to be broken. We recommend to use the original shipping packages.

PRODUCT GROUP		REV	ISSUE DATE	BOE
TFT- LCD PRODUCT		P0	2020-11-15	
SPEC. NUMBER	SPEC. TITLE			PAGE
S8-*	B3 EV121WXM-N12 Product Specification			32 OF 33

9.0 APPENDIX

Mechanical Drawing
Drawing Attachment: Landscape Front View

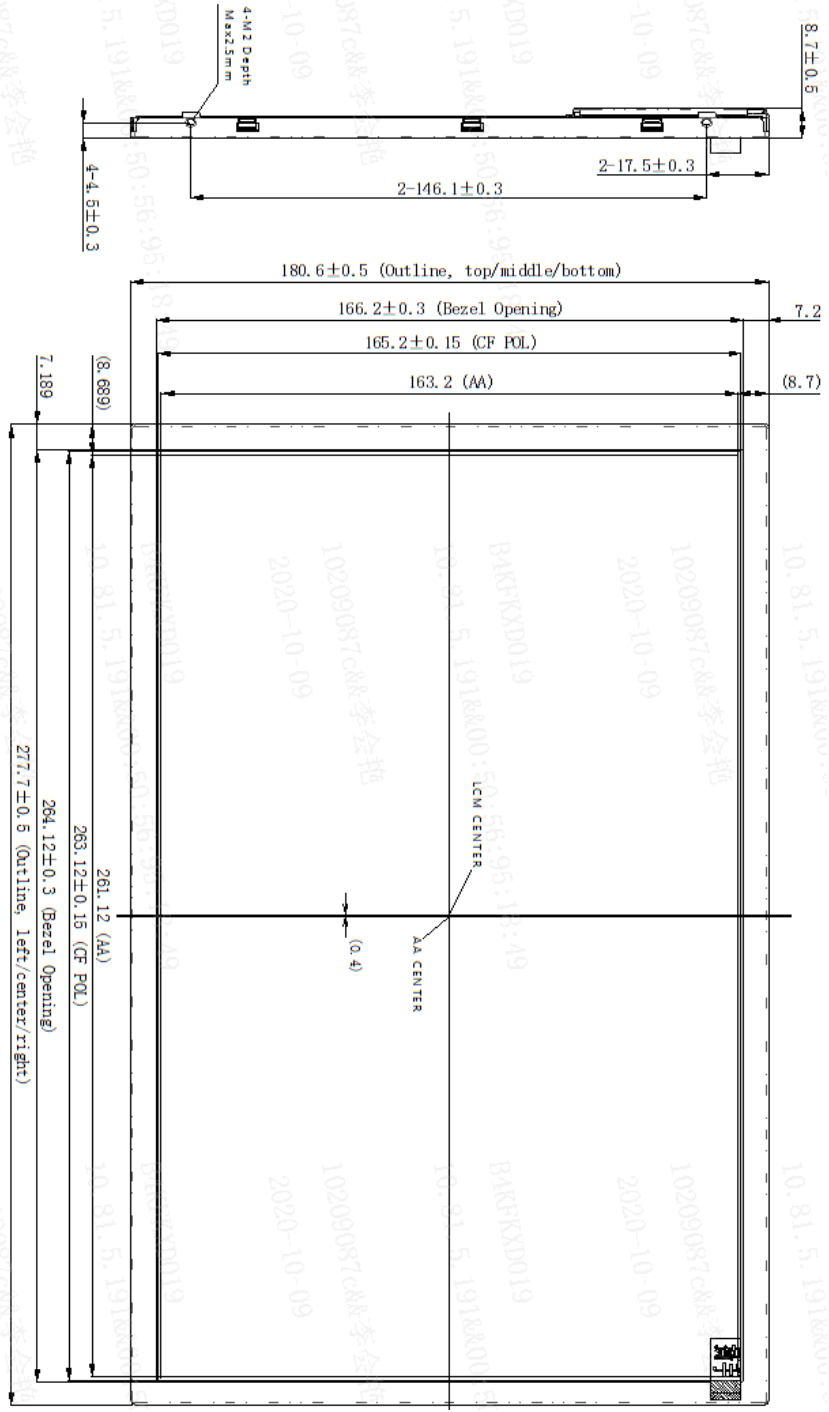

Mechanical Drawing

Drawing Attachment: Landscape Back View

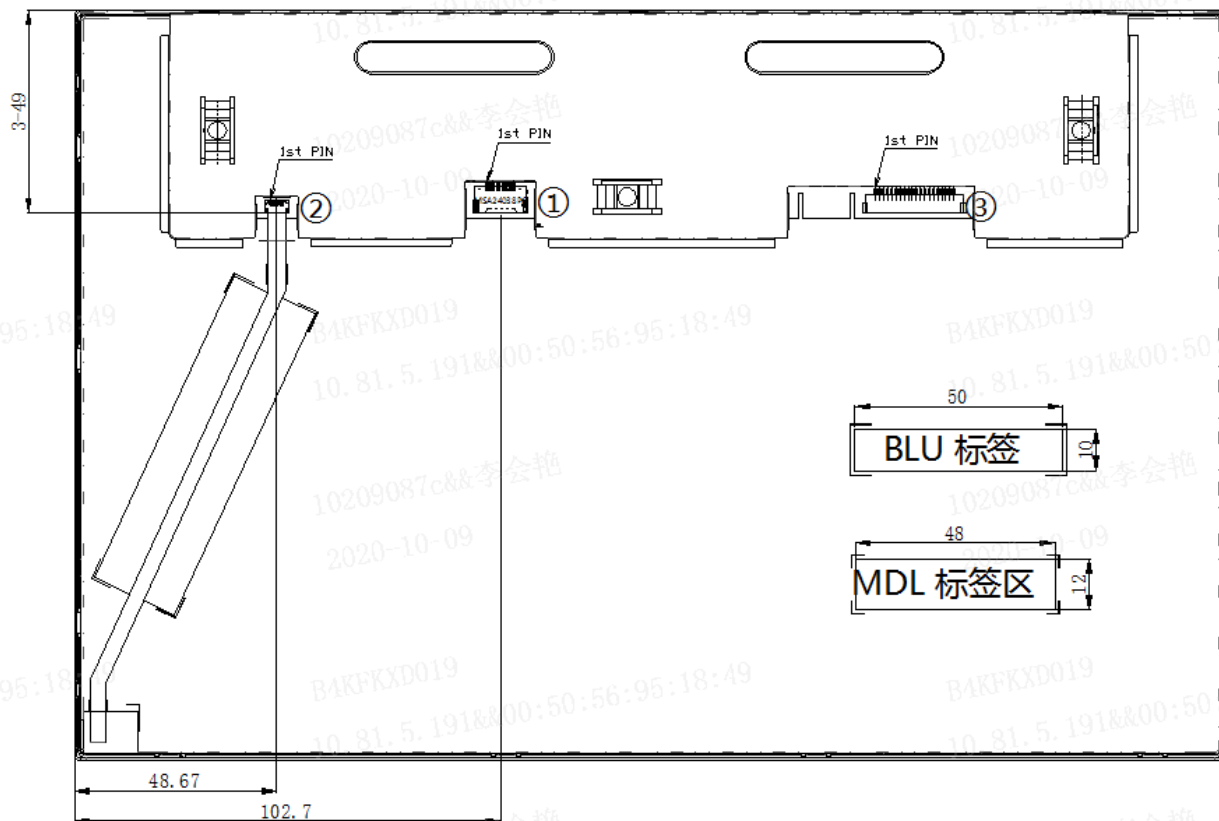

备注：

1. DISPLAY MODE: ADS NB TRANSMISSIVE.
2. OPERATING TEMPERATURE: -20°C TO 70°C.
3. STORAGE TEMPERATURE: -30°C TO 80°C.
4. LCD DRIVER SOURCE IC: EK79202 , 2EA/MDL
5. BACKLIGHT: 48 CHIP WHITE LEDS.
6. LCM BRIGHTNESS: 400CD/M2 MIN, 500CD/M2 TYP.
7. RECOMMEND CONNECTOR:
 - ① 6pin CNT SPEC:MSA24038P6
 - ② 9pin CNT SPEC: PF040-B09B-C09
 - ③ 20pin CNT SPEC:DF19G-20P-1H (54)
8. Calculator Value for reference $I_{LED} \times V_{LED} \times LED \text{ Quantity} = P_{LED}$.