

# Model Name: P290IAN01.0

Issue Date : 2019/04/16

( ) Preliminary Specifications

(\* ) Final Specifications

Customer Signature	Date	AUO	Date
Approved By  _____		Approval By PM Director CT Wu 	
Note		Reviewed By RD Director Jack Hsu 	
		Reviewed By Project Leader Spark Lin 	
		Prepared By PM Lorenz Shiau 	

## Contents

<b>Record of Revision .....</b>	<b>3</b>
<b>1. General Description.....</b>	<b>5</b>
<b>2. Absolute Maximum Ratings.....</b>	<b>10</b>
<b>3. Electrical Specification .....</b>	<b>11</b>
<b>3.1 Power Specification .....</b>	<b>12</b>
<b>3.2 Signal Electrical Characteristics.....</b>	<b>13</b>
<b>3.3 Signal Characteristic .....</b>	<b>14</b>
<b>3.4 Input Data Format .....</b>	<b>17</b>
<b>3.5 Signal Timing Specification .....</b>	<b>18</b>
<b>3.6 Signal Timing Waveforms .....</b>	<b>19</b>
<b>3.7 Power Sequence.....</b>	<b>20</b>
• <b>Power On/Off Sequence of LCD.....</b>	<b>20</b>
<b>4. Backlight Specification .....</b>	<b>21</b>
<b>4.1 Electrical specification .....</b>	<b>21</b>
<b>4.2 Input Pin Assignment .....</b>	<b>22</b>
<b>5. Mechanical Characteristics .....</b>	<b>23</b>
<b>6. Reliability Test Items .....</b>	<b>26</b>
<b>7. International Standard.....</b>	<b>27</b>
7.1 Safety.....	27
7.2 EMC.....	27
<b>8. Packing.....</b>	<b>28</b>
<b>8.1 DEFINITION OF LABEL:.....</b>	<b>28</b>
<b>8.2 Pallet and Shipment Information .....</b>	<b>29</b>
<b>9. PRECAUTIONS .....</b>	<b>30</b>
<b>9.1 MOUNTING PRECAUTIONS .....</b>	<b>30</b>
<b>9.2 OPERATING PRECAUTIONS .....</b>	<b>30</b>
9.3 Operating Condition for Public Information Display.....	31
9.4 Electrostatic Discharge Control.....	31
9.5 Precautions for Strong Light Exposure.....	31
9.6 Storage.....	31
9.7 Handling Precautions for Protection Film .....	32
<b>9.8 Dust Resistance .....</b>	<b>32</b>

## Record of Revision

Version	Date	Page	Description																																									
0.0	2018/02/14	All	First preliminary spec sheet release																																									
0.1	2018/03/29	4	Surface treatment updated (AG 2%)																																									
1.0	2018/08/01	4	Adding the description: "LED driver board is not included"																																									
		8	Absolute Maximum Ratings: panel surface temperature: 70→65 degree																																									
		10~12	Reforming the content of electrical specification: removing LED driver.																																									
		18	Power Sequence: t1 max. value 30→10ms																																									
		20	Backlight Specification update: <table border="1" data-bbox="560 723 1050 817"> <thead> <tr> <th>Item</th> <th>Parameter</th> <th>Symbol</th> <th>Min</th> <th>Spec Typ</th> <th>Max</th> <th>Unit</th> <th>Note</th> </tr> </thead> <tbody> <tr> <td>1</td> <td>Forward Voltage</td> <td>V<sub>f</sub> LED</td> <td>-</td> <td>38.4</td> <td>43.2</td> <td>Volt</td> <td>1</td> </tr> <tr> <td>2</td> <td>LED Forward Current</td> <td>I<sub>f</sub></td> <td>-</td> <td>95</td> <td>-</td> <td>mA</td> <td>1</td> </tr> <tr> <td>3</td> <td>LED Power Consumption (Single light bar)</td> <td>P<sub>LED</sub></td> <td>-</td> <td>30.4</td> <td>37</td> <td>Watt</td> <td>1</td> </tr> <tr> <td>4</td> <td>LED Life Time</td> <td>LTLED</td> <td>50,000</td> <td>-</td> <td>-</td> <td>Hrs</td> <td>1,4</td> </tr> </tbody> </table>	Item	Parameter	Symbol	Min	Spec Typ	Max	Unit	Note	1	Forward Voltage	V <sub>f</sub> LED	-	38.4	43.2	Volt	1	2	LED Forward Current	I <sub>f</sub>	-	95	-	mA	1	3	LED Power Consumption (Single light bar)	P <sub>LED</sub>	-	30.4	37	Watt	1	4	LED Life Time	LTLED	50,000	-	-	Hrs	1,4	
		Item	Parameter	Symbol	Min	Spec Typ	Max	Unit	Note																																			
		1	Forward Voltage	V <sub>f</sub> LED	-	38.4	43.2	Volt	1																																			
		2	LED Forward Current	I <sub>f</sub>	-	95	-	mA	1																																			
		3	LED Power Consumption (Single light bar)	P <sub>LED</sub>	-	30.4	37	Watt	1																																			
		4	LED Life Time	LTLED	50,000	-	-	Hrs	1,4																																			
22~24	Adding the definition of outlines dimension and drawings.																																											
28	Updating the definition of Pallet and Shipment Information																																											
26	Updating the definition of safety.																																											
31	Adding the definition of Dust Resistance																																											
1.1	2018/11/19	9	1. Removing the description of light-bar: 2. Revising the Connector: JAE / SJ11346-FI-RTE51SZ-HF																																									
		12	Revising the connector: <table border="1" data-bbox="560 1178 1235 1299"> <thead> <tr> <th>Connector Name / Designation</th> <th>LED Connector</th> </tr> </thead> <tbody> <tr> <td>Manufacturer</td> <td>JAE</td> </tr> <tr> <td>Type Part Number</td> <td>SJ11346-FI-RTE51SZ-HF or equivalent</td> </tr> <tr> <td>Mating Housing Part Number</td> <td>JAE FI-RE51S-HF or compatible</td> </tr> </tbody> </table>	Connector Name / Designation	LED Connector	Manufacturer	JAE	Type Part Number	SJ11346-FI-RTE51SZ-HF or equivalent	Mating Housing Part Number	JAE FI-RE51S-HF or compatible																																	
		Connector Name / Designation	LED Connector																																									
		Manufacturer	JAE																																									
		Type Part Number	SJ11346-FI-RTE51SZ-HF or equivalent																																									
		Mating Housing Part Number	JAE FI-RE51S-HF or compatible																																									
17	Adding the remark of signal timing specification: Note 1: DE mode only. Note 2: The above is as optimized setting Note 3: Clock min. < Vertical*Horizontal* Frame Rate < Clock max.																																											
19	Revising Power On/Off Sequence of LCD <table border="1" data-bbox="560 1565 1302 1686"> <thead> <tr> <th rowspan="2">Parameter</th> <th colspan="2">Values</th> <th rowspan="2">Unit</th> </tr> <tr> <th>Min</th> <th>Max</th> </tr> </thead> <tbody> <tr> <td>t1</td> <td>0.5</td> <td>30</td> <td>ms</td> </tr> <tr> <td>t2</td> <td>10</td> <td>50</td> <td>ms</td> </tr> </tbody> </table>	Parameter	Values		Unit	Min	Max	t1	0.5	30	ms	t2	10	50	ms																													
Parameter	Values		Unit																																									
	Min	Max																																										
t1	0.5	30	ms																																									
t2	10	50	ms																																									
20	Backlight Specification update: <table border="1" data-bbox="560 1758 1211 1881"> <thead> <tr> <th rowspan="2">Item</th> <th rowspan="2">Parameter</th> <th rowspan="2">Symbol</th> <th colspan="3">Spec</th> <th rowspan="2">Unit</th> <th rowspan="2">Note</th> </tr> <tr> <th>Min</th> <th>Typ</th> <th>Max</th> </tr> </thead> <tbody> <tr> <td>1</td> <td>Forward Voltage</td> <td>V<sub>f</sub> LED</td> <td>-</td> <td>38.4</td> <td>43.2</td> <td>Volt</td> <td>1</td> </tr> <tr> <td>2</td> <td>LED Forward Current</td> <td>I<sub>f</sub></td> <td>-</td> <td>95</td> <td>-</td> <td>mA</td> <td>1</td> </tr> <tr> <td>3</td> <td>LED Power Consumption (Single light bar)</td> <td>P<sub>LED</sub></td> <td>-</td> <td>14.6</td> <td>16.4</td> <td>Watt</td> <td>1</td> </tr> <tr> <td>4</td> <td>LED Life Time</td> <td>LTLED</td> <td>50,000</td> <td>-</td> <td>-</td> <td>Hrs</td> <td>1,4</td> </tr> </tbody> </table>	Item	Parameter	Symbol	Spec			Unit	Note	Min	Typ	Max	1	Forward Voltage	V <sub>f</sub> LED	-	38.4	43.2	Volt	1	2	LED Forward Current	I <sub>f</sub>	-	95	-	mA	1	3	LED Power Consumption (Single light bar)	P <sub>LED</sub>	-	14.6	16.4	Watt	1	4	LED Life Time	LTLED	50,000	-	-	Hrs	1,4
Item	Parameter				Symbol	Spec				Unit	Note																																	
		Min	Typ	Max																																								
1	Forward Voltage	V <sub>f</sub> LED	-	38.4	43.2	Volt	1																																					
2	LED Forward Current	I <sub>f</sub>	-	95	-	mA	1																																					
3	LED Power Consumption (Single light bar)	P <sub>LED</sub>	-	14.6	16.4	Watt	1																																					
4	LED Life Time	LTLED	50,000	-	-	Hrs	1,4																																					
23	Drawings update: removing the "AUO" logo.																																											
1.2	2019/06/26	5-6	Update Special material(s) applied / Display Orientation to Portrait / Landscape enabled and schematic diagram																																									
		13	Pin definition- Pin#7 update: Open/High(3.3V) for NS, Low(GND) for JEIDA																																									

---

		15	Remove 10bit definition(not supported)
		31	Revise operating time from 20 to 24 hours

## 1. General Description

This specification applies to the 29.0 inch Color TFT-LCD Module P290IAN01.0. This LCD module has a TFT active matrix type liquid crystal panel 1,920x540 pixels, and diagonal size of 28.6 inch. This module supports 1,920x540 resolution display. Each pixel is divided into Red, Green and Blue sub-pixels or dots which are arranged in vertical stripes. Gray scale or the brightness of the sub-pixel color is determined with a 8-bit gray scale signal for each dot.

The P290IAN01.0 has been designed to apply the 8-bit 2 channel LVDS interface method. The main feature of P290IAN01.0 would be high brightness, wide viewing angle, and edge LED backlight. High Tni (110°C) liquid crystal also applies on this model.

LED driver board is not included. P290IAN01.0 is designed for industrial display applications.

Special material(s) applied into this model is(are):

1. Liquid crystal: High Tni LC (110°C)

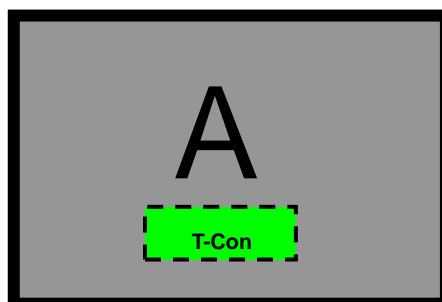
Items	Specification	Unit	Note
Active Screen Size	28.6	Inch	
Display Area	698.400 (H) x 196.425 (V)	mm	
Outline Dimension	731.46(H) x 229.49(V) x 20.34(D)	mm	
Driver Element	a-Si TFT active matrix		
Display Colors	16.7M colors (true 8-bit)	Colors	
Number of Pixels	1,920x540	Pixel	
Pixel Pitch	363.75 (per one triad) x363.75	um	
Pixel Arrangement	RGB vertical stripe		
Display Operation Mode	AHVA Mode, Normally Black		
Display Orientation	Portrait/Landscape Enabled		Note 1
Surface Treatment	Haze 2%, 3H		

Note 1:

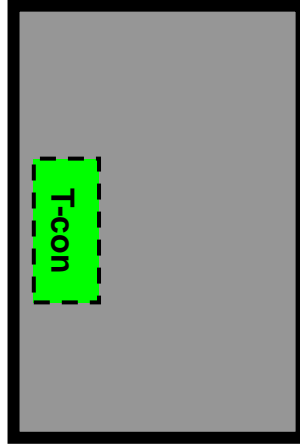
(1) **Landscape Mode:** The default placement is T-Con Side on the upper side and the image is shown upright via viewing from the front.

(2) **Portrait Mode:** The default placement is that T-Con side has to be placed on the right side via viewing from the front.

**Landscape (Front view)**



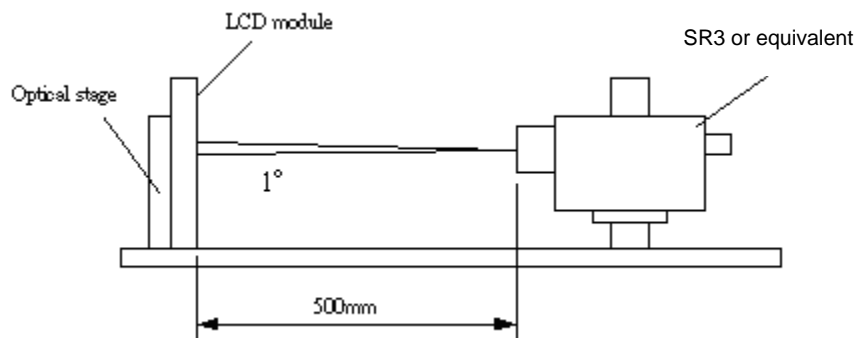
**Portrait (Front view)**



### 1.1 Optical Specification

Optical characteristics are determined after the unit has been 'ON' and stable for approximately 45 minutes in a dark environment at 25°C while panel is placed in the default position. The default position is T-con side as the top side of panel. The value specified is at an approximate distance 50cm from the LCD surface at a viewing angle of  $\phi$  and  $\theta$  equal to 0°.

**Fig.1 presents additional information concerning the measurement equipment and method.**



Parameter	Symbol	Values			Unit	Notes
		Min.	Typ.	Max		
Contrast Ratio	CR	800	1000	--		1
Surface Luminance (White)	L <sub>WH</sub>	560	700	--	cd/m <sup>2</sup>	2
Luminance Variation	$\delta_{\text{WHITE(9P)}}$	--	--	1.33		3
Response Time (G to G)	T <sub>γ</sub>	--	25	--	ms	4
Color Gamut	NTSC		72		%	
Color Coordinates						
Red	R <sub>X</sub>	Typ.-0.05	0.640	Typ.+0.05		
	R <sub>Y</sub>		0.345			
Green	G <sub>X</sub>		0.324			
	G <sub>Y</sub>		0.627			
Blue	B <sub>X</sub>		0.152			
	B <sub>Y</sub>		0.057			
White	W <sub>X</sub>		0.313			
	W <sub>Y</sub>		0.329			
Viewing Angle						
	x axis, right( $\phi=0^\circ$ )	$\theta_r$	75	89	--	degree
	x axis, left( $\phi=180^\circ$ )	$\theta_l$	75	89	--	degree
	y axis, up( $\phi=90^\circ$ )	$\theta_u$	75	89	--	degree
	y axis, down ( $\phi=270^\circ$ )	$\theta_d$	75	89	--	degree

Note:

1. Contrast Ratio (CR) is defined mathematically as:

$$\text{Contrast Ratio} = \frac{\text{Surface Luminance of } L_{on5}}{\text{Surface Luminance of } L_{off5}}$$

2. Surface luminance is luminance value at point 5 across the LCD surface 50cm from the surface with all pixels displaying white. From more information see FIG 2. When lamp current  $I_H = 11\text{mA}$ .  $L_{WH} = L_{on5}$  where  $L_{on5}$  is the luminance with all pixels displaying white at center 5 location.

3. The variation in surface luminance,  $\delta_{WHITE}$  is defined (center of Screen) as:

$$\delta_{WHITE(9P)} = \frac{\text{Maximum}(L_{on1}, L_{on2}, \dots, L_{on9})}{\text{Minimum}(L_{on1}, L_{on2}, \dots, L_{on9})}$$

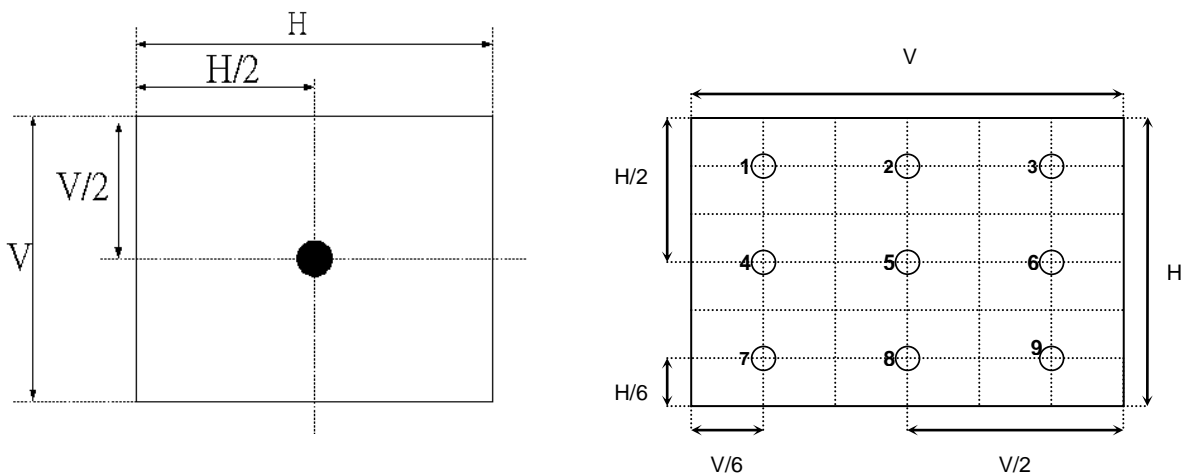
4. Response time  $T_\gamma$  is the average time required for display transition by switching the input signal for five luminance ratio (0%,25%,50%,75%,100% brightness matrix) and is based on  $F_v = 60\text{Hz}$  to optimize.

$T_\gamma$  is determined by 10% to 90% brightness difference of rising or falling period. (As illustrated)

Measured Response Time		Target				
		0%	25%	50%	75%	100%
Start	0%		0% to 25%	0% to 50%	0% to 75%	0% to 100%
	25%	25% to 0%		25% to 50%	25% to 75%	25% to 100%
	50%	50% to 0%	50% to 25%		50% to 75%	50% to 100%
	75%	75% to 0%	75% to 25%	75% to 50%		75% to 100%
	100%	100% to 0%	100% to 25%	100% to 50%	100% to 75%	

5. Viewing angle is the angle at which the contrast ratio is greater than 10. The angles are determined for the horizontal or x axis and the vertical or y axis with respect to the z axis which is normal to the LCD surface. For more information see FIG4.

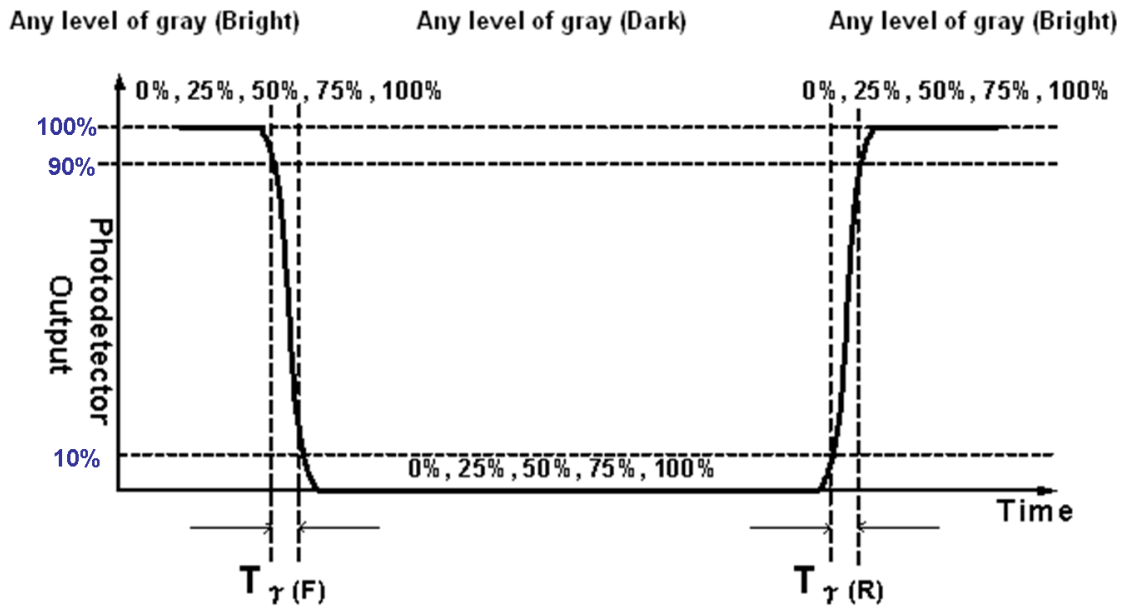
**FIG. 2 Luminance**



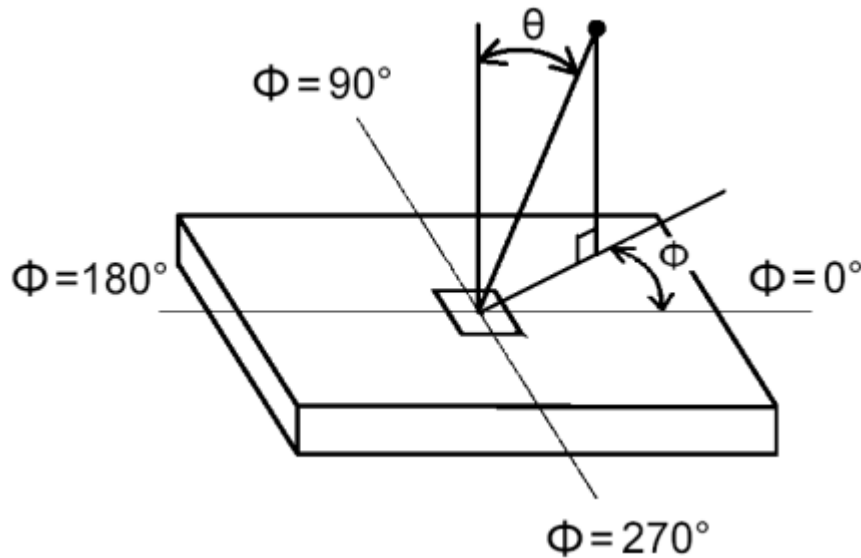


**FIG.3 Response Time**

The response time is defined as the following figure and shall be measured by switching the input signal for “any level of gray(bright)” and “any level of gray(dark)”.



**FIG.4 Viewing Angle**



## 2. Absolute Maximum Ratings

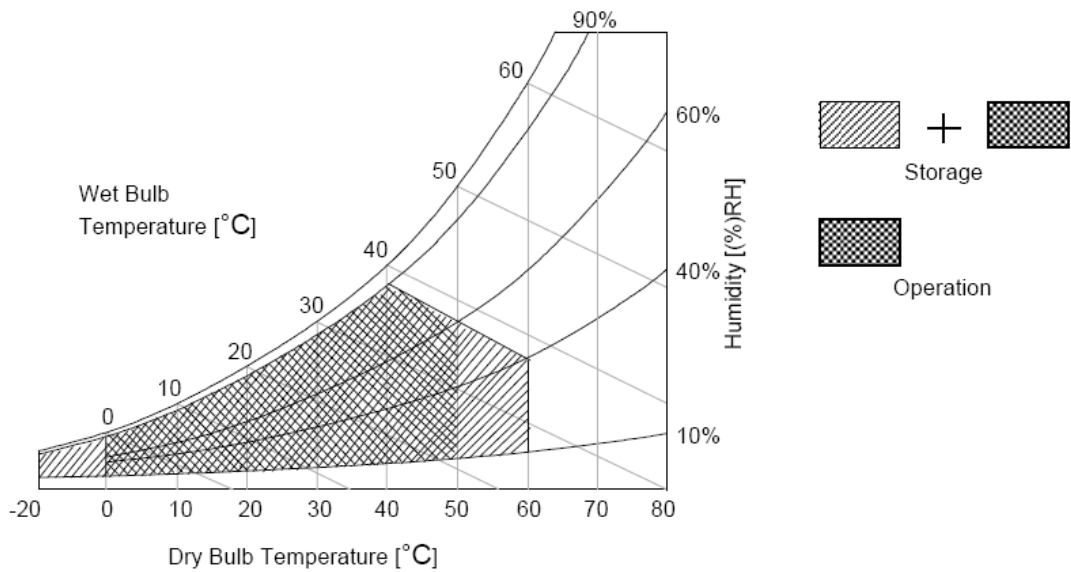
The followings are maximum values which, if exceeded, may cause faulty operation or damage to the unit

Item	Symbol	Min	Max	Unit	Conditions
Operating Temperature	TOP	0	+50	[°C]	Note 2
Operating Humidity	HOP	10	90	[%RH]	Note 2
Storage Temperature	TST	-20	+60	[°C]	Note 2
Storage Humidity	HST	10	90	[%RH]	Note 2
Panel Surface Temperature	PST		65	[°C]	Note 3

Note 1: Duration:50 msec.

Note 2 : Permanent damage to the device may occur if exceeding maximum values

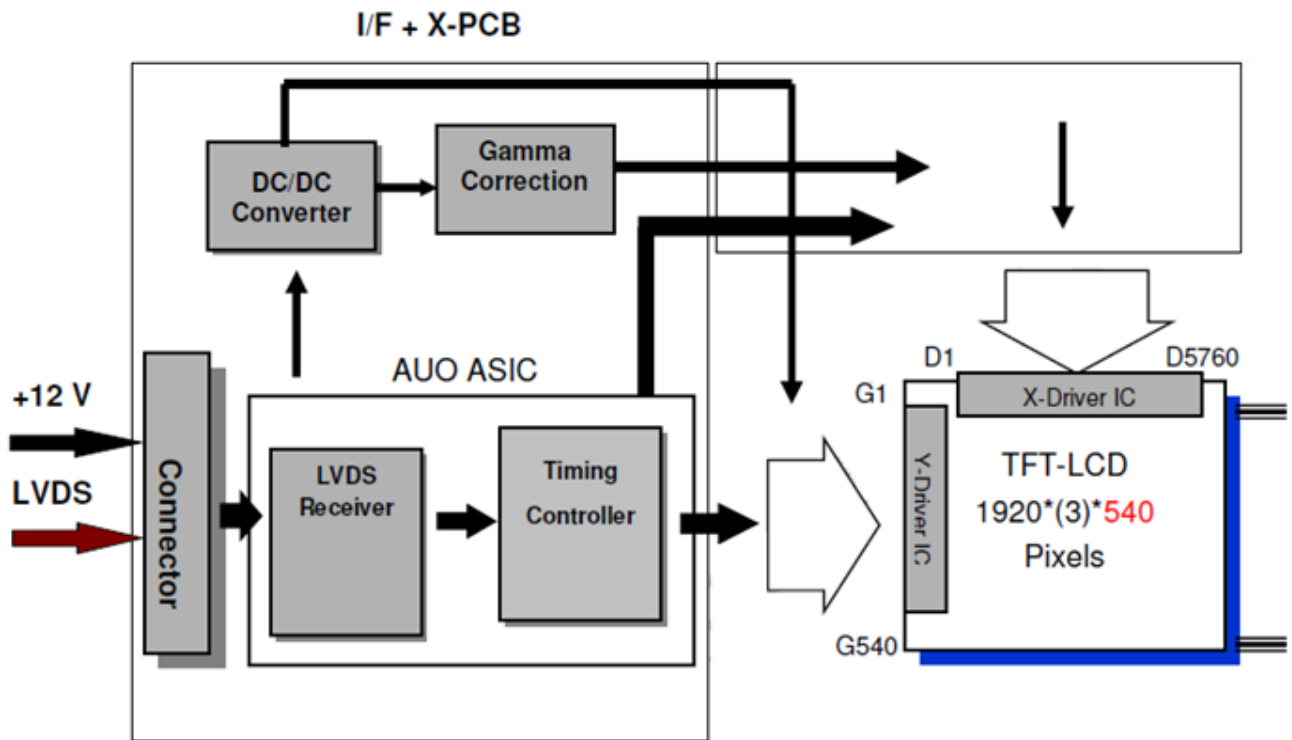
Note 3: Surface temperature is measured at 50°C Dry condition



### 3. Electrical Specification

The P290IAN01.0 requires two power inputs. One is employed to power the LCD electronics and to drive the TFT array and liquid crystal. The second is to power Back Light Unit.

The following diagram shows the functional block of the 28.6 inches wide Color TFT-LCD Module:



Note:

LVDS Connector: [JAE SJ11346-FI-RTE51SZ-HF](#) or equivalent.

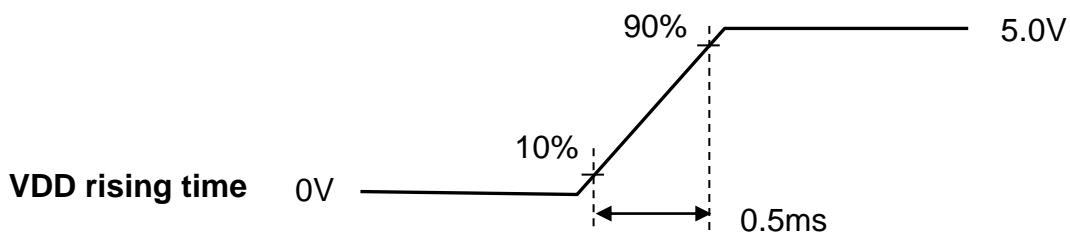
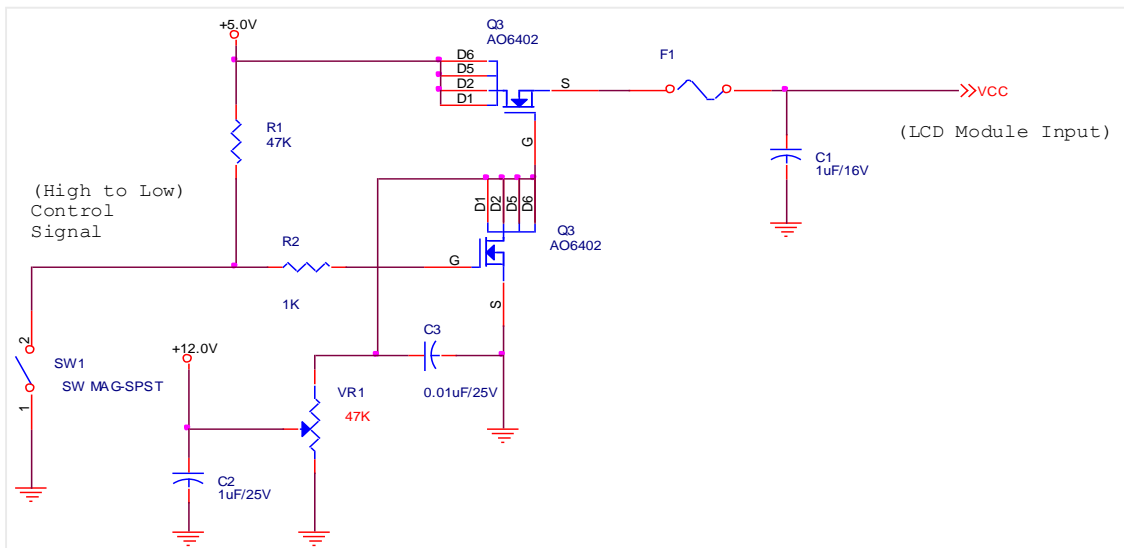
LED light bar Connector: [ENTERY 3707K-S06N-01L](#) or equivalent.

### 3.1 Power Specification

Parameter	Symbol	Value			Unit	Remark
		Min.	Typ.	Max		
Power Supply Input Voltage	V <sub>DD</sub>	10.8	12	13.2	[Volt]	±10%
Power Supply Input Current	I <sub>DD</sub>	--	--	292	[mA]	Note 1
Power Consumption	P <sub>C</sub>	--	--	3.5	[Watt]	Note 2
Inrush Current	I <sub>RUSH</sub>	-	-	3	[A]	Note 1

**Note :**

1. Test Condition:
  - (1) V<sub>DD</sub> = 12.0V
  - (2) F<sub>v</sub> = Type Timing, 60Hz
  - (3) Temperature = 25 °C
  - (4) Test Pattern : White Pattern
  
2. Measurement condition : Rising time = 500us

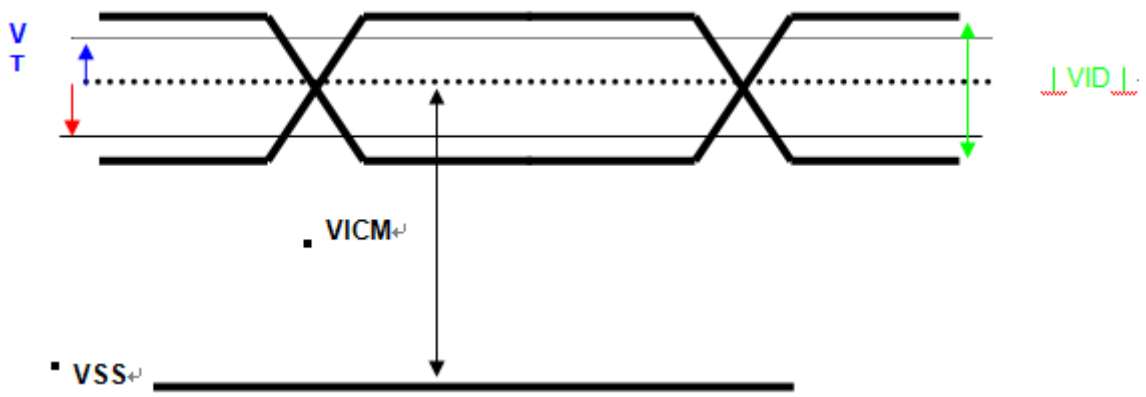


### 3.2 Signal Electrical Characteristics

Input signals shall be low or Hi-Z state when VDD is off.

Parameter	Symbol	Value			Unit	Remark
		Min.	Typ.	Max		
Input Differential Voltage	$ V_{ID} $	100	400	600	mV <sub>DC</sub>	
Differential Input High Threshold	$V_{TH}$		--	+100	mV <sub>DC</sub>	V <sub>CM</sub> =1.2V
Differential Input Low Threshold	$V_{TL}$	-100	--		mV <sub>DC</sub>	V <sub>CM</sub> =1.2V
Differential Input Common Mode Voltage	$V_{ICM}$	1.0	1.2	1.5	V <sub>DC</sub>	V <sub>TH</sub> /V <sub>TL</sub> =±100mV

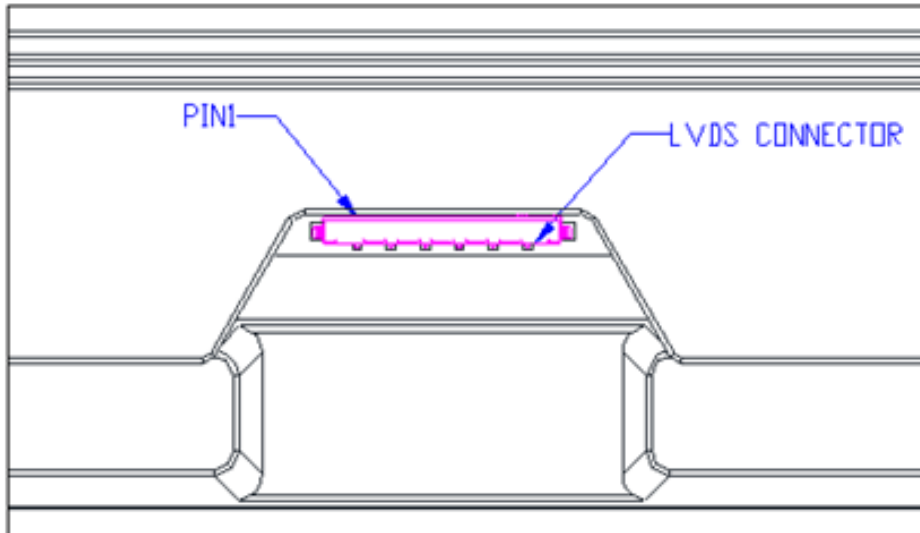
**Note :** LVDS Signal Waveform.



### 3.3 Signal Characteristic

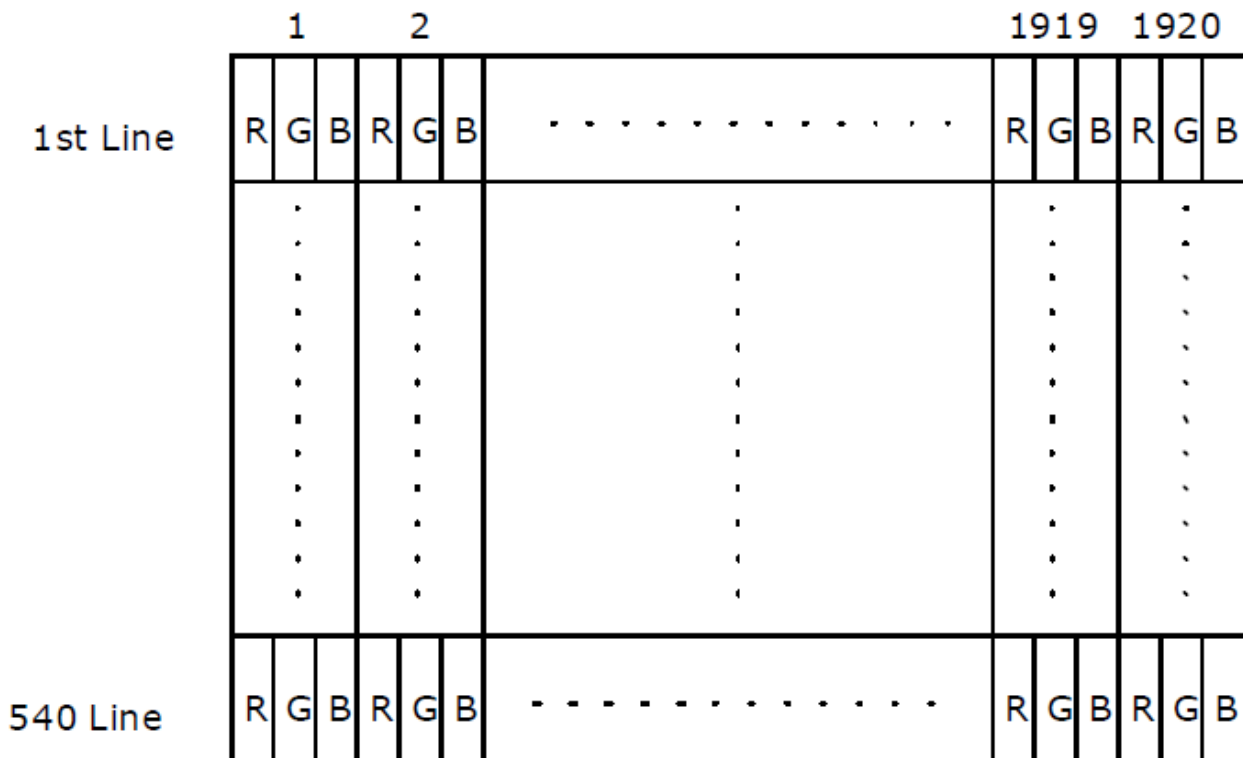
#### 3.3.1 TFT LCD Module: LVDS Connector

Connector Name / Designation	LED Connector
Manufacturer	JAE
Type Part Number	SJ11346-FI-RTE51SZ-HF or equivalent.
Mating Housing Part Number	JAE FI-RE51S-HF or compatible



#### 3.3.2 Pixel Format Image

Following figure shows the relationship of the input signals and LCD pixel format.



### 3.3.3 Interface Connections

The module using a pair of LVDS receiver SN75LVDS82(Texas Instruments) or compatible. LVDS is a differential signal technology for LCD interface and high speed data transfer device. Transmitter shall be SN75LVDS83(negative edge sampling) or compatible. The first LVDS port transmits odd pixels while the second LVDS port transmits even pixels.

PIN #	SIGNAL NAME	DESCRIPTION
1	N.C.	No Connection
2	N.C.	No Connection
3	N.C.	No Connection
4	N.C.	No Connection
5	N.C.	No Connection
6	N.C.	No Connection
7	SELLVDS	Open/High(3.3V) for NS, Low(GND) for JEIDA
8	N.C.	No Connection
9	N.C.	No Connection
10	N.C.	No Connection
11	GND	Power Ground
12	RXinO0-	Negative LVDS differential data input (Odd data)
13	RXinO0+	Positive LVDS differential data input (Odd data)
14	RXinO1-	Negative LVDS differential data input (Odd data)
15	RXinO1+	Positive LVDS differential data input (Odd data)
16	RXinO2-	Negative LVDS differential data input (Odd data, H-Sync, V-Sync, DSPTMG)
17	RXinO2+	Positive LVDS differential data input (Odd data, H-Sync, V-Sync, DSPTMG)
18	GND	Power Ground
19	RxOCLKIN-	Negative LVDS differential clock input (Odd clock)
20	RxOCLKIN+	Positive LVDS differential clock input (Odd clock)
21	GND	
22	RXinO3-	Negative LVDS differential data input (Odd data)
23	RXinO3+	Positive LVDS differential data input (Odd data)
24	N.C.	No contact (For AUO test only)
25	N.C.	No contact (For AUO test only)
26	N.C.	No contact (For AUO test only)
27	N.C.	No contact (For AUO test only)
28	RXinE0-	Negative LVDS differential data input (Even data)
29	RXinE0+	Positive LVDS differential data input (Even data)

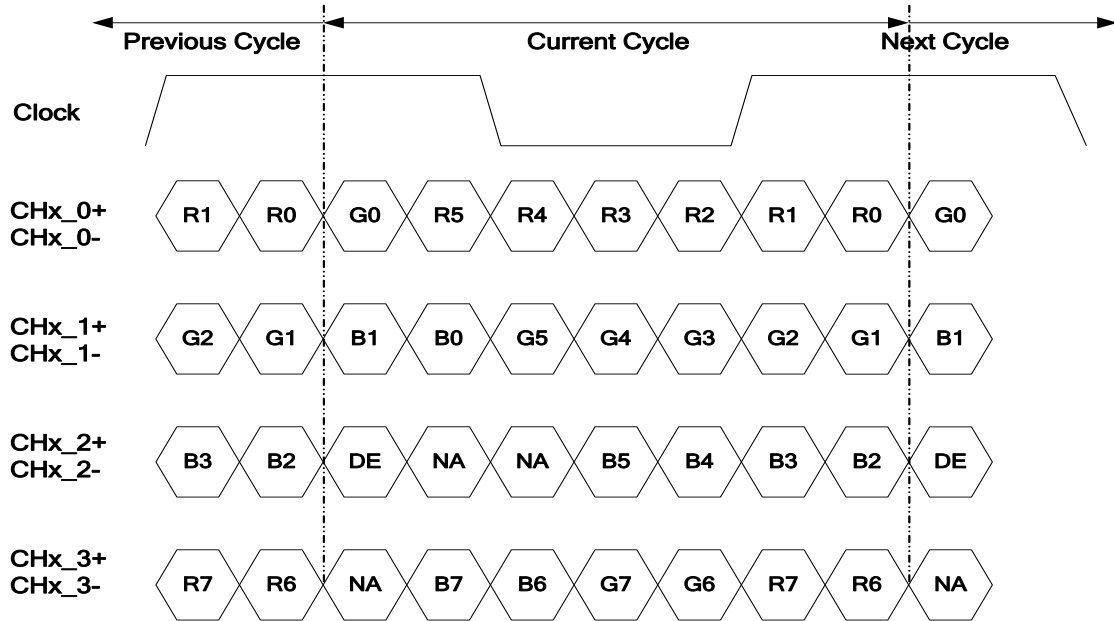
30	RXinE1-	Negative LVDS differential data input (Even data)
31	RXinE1+	Positive LVDS differential data input (Even data)
32	RXinE2-	Negative LVDS differential data input (Even data)
33	RXinE2+	Positive LVDS differential data input (Even data)
34	GND	
35	RxECLKIN-	Negative LVDS differential clock input (Even clock)
36	RxECLKIN+	Positive LVDS differential clock input (Even clock)
37	GND	
38	RXinE3-	Negative LVDS differential data input (Even data)
39	RXinE3+	Positive LVDS differential data input (Even data)
40	N.C.	No Connection
41	N.C.	No Connection
42	GND	Ground
43	GND	Ground
44	GND	Ground
45	GND	Ground
46	GND	Ground
47	N.C.	No Connection
48	VDD	Power +12V
49	VDD	Power +12V
50	VDD	Power +12V
51	VDD	Power +12V

**Note.** Pin number start from the left side as the following figure.



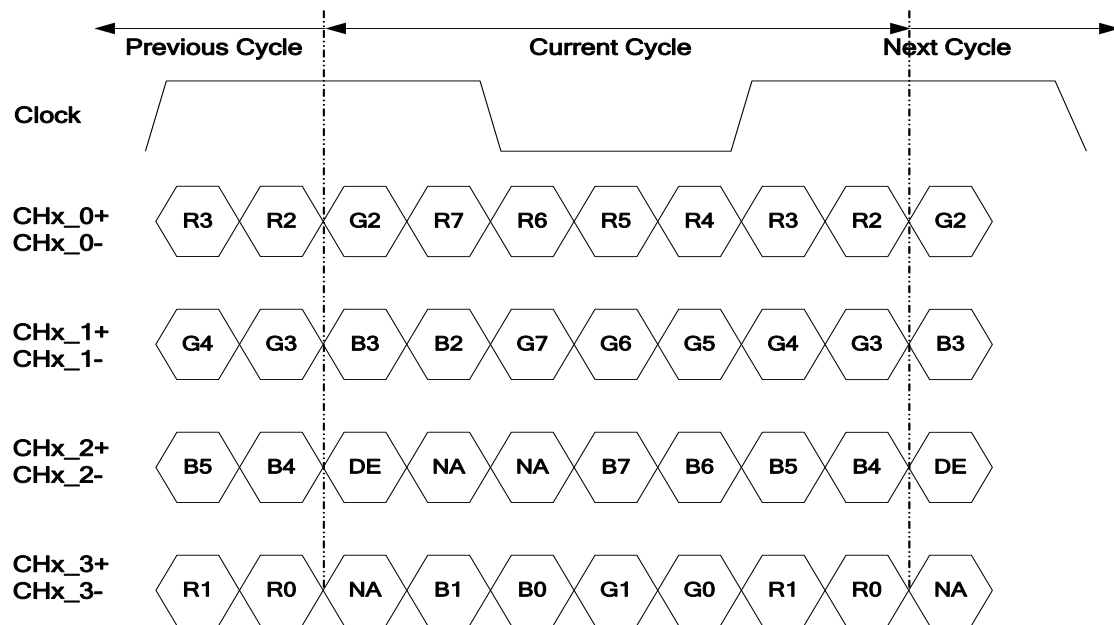
### 3.4 Input Data Format

#### ■ LVDS Option NS



Note: x = 1, 2, 3, 4...

#### ■ LVDS Option JEIDA



Note: x = 1, 2, 3, 4...

### 3.5 Signal Timing Specification

This is the signal timing required at the input of the user connector. All of the interface signal timing should be satisfied with the following specifications for its proper operation.

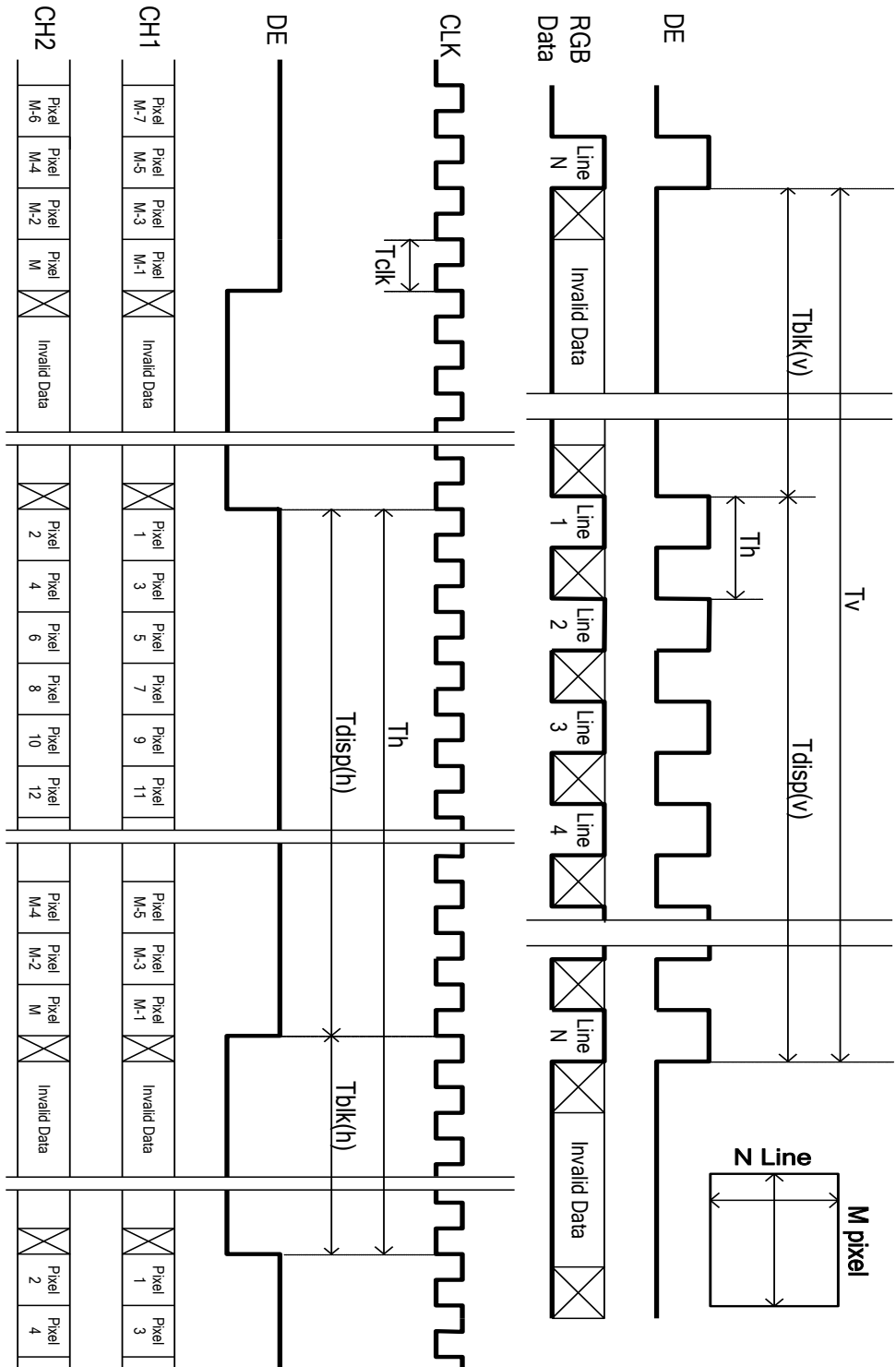
Signal	Item	Symbol	Min.	Typ.	Max	Unit
Clock	Frequency	$F_{\text{Clock}}=1/T_{\text{Clock}}$	42	45	48	MHz
Frame Rate	Frequency	$F_v=1/T_v$	47	60	63	Hz
Vertical Section	Period	$T_v$	560	585	740	T_line
	Active	$T_{vD}$	540			
	Blanking	$T_{vB}$	20	45	200	
Horizontal Section	Period	$T_H$	1030	1283	1325	T_clock
	Active	$T_{HD}$	960			
	Blanking	$T_{HB}$	70	323	365	

**Note 1:** DE mode only.

**Note 2:** The above is as optimized setting

**Note 3:** Clock min. < Vertical\*Horizontal\* Frame Rate < Clock max.

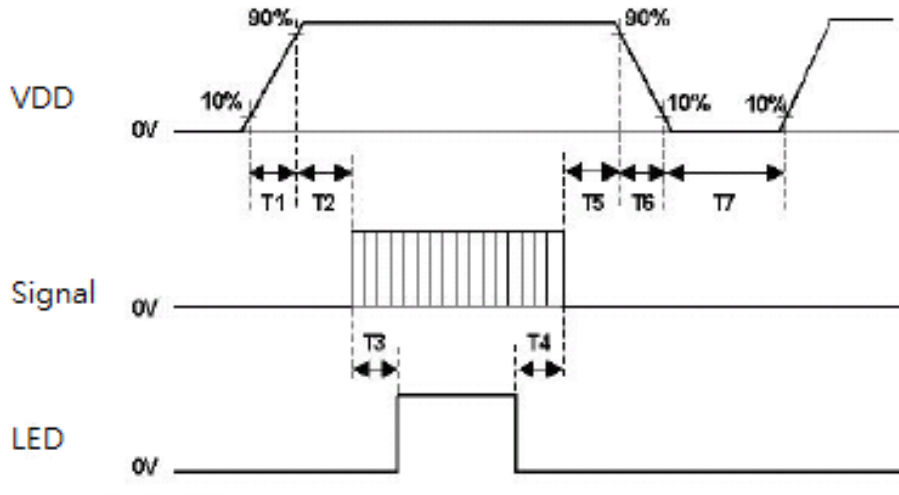
### 3.6 Signal Timing Waveforms



### 3.7 Power Sequence

#### ◆ Power On/Off Sequence of LCD

VDD power on/off sequence is as follows. Interface signals are also shown in the chart. Signals from any system shall be Hi-Z state or low level when VDD is off.



Parameter	Values		Unit
	Min.	Max.	
t1	0.5	30	ms
t2	10	50	ms
t3	200	-	ms
t4	200	-	ms
t5	0	50	ms
t6	0	10	ms
t7	1000	-	ms

Note: The above on/off sequence should be applied to avoid abnormal function in the display. Please make sure to turn off the power when you plug the cable into the input connector or pull the cable out of the connector.

## 4. Backlight Specification

### 4.1 Electrical specification

Item	Parameter	Symbol	Spec			Unit	Note
			Min	Typ	Max		
1	Forward Voltage	V <sub>f</sub> LED		38.4	43.2	Volt	1-
2	LED Forward Current	I <sub>F</sub>	--	95		mA	1
3	LED Power Consumption (Singal light bar)	P <sub>LED</sub>	--	14.6	16.4	Walt	1
4	LED Life Time	LTLED	50,000	--	--	Hrs	1,4

Note 1: V<sub>f</sub> LED=3.2V/pcs LED\*12 pcs/string

Note 2 : P<sub>LED</sub> =38.4V\*0.095A\*4 string =14.6W

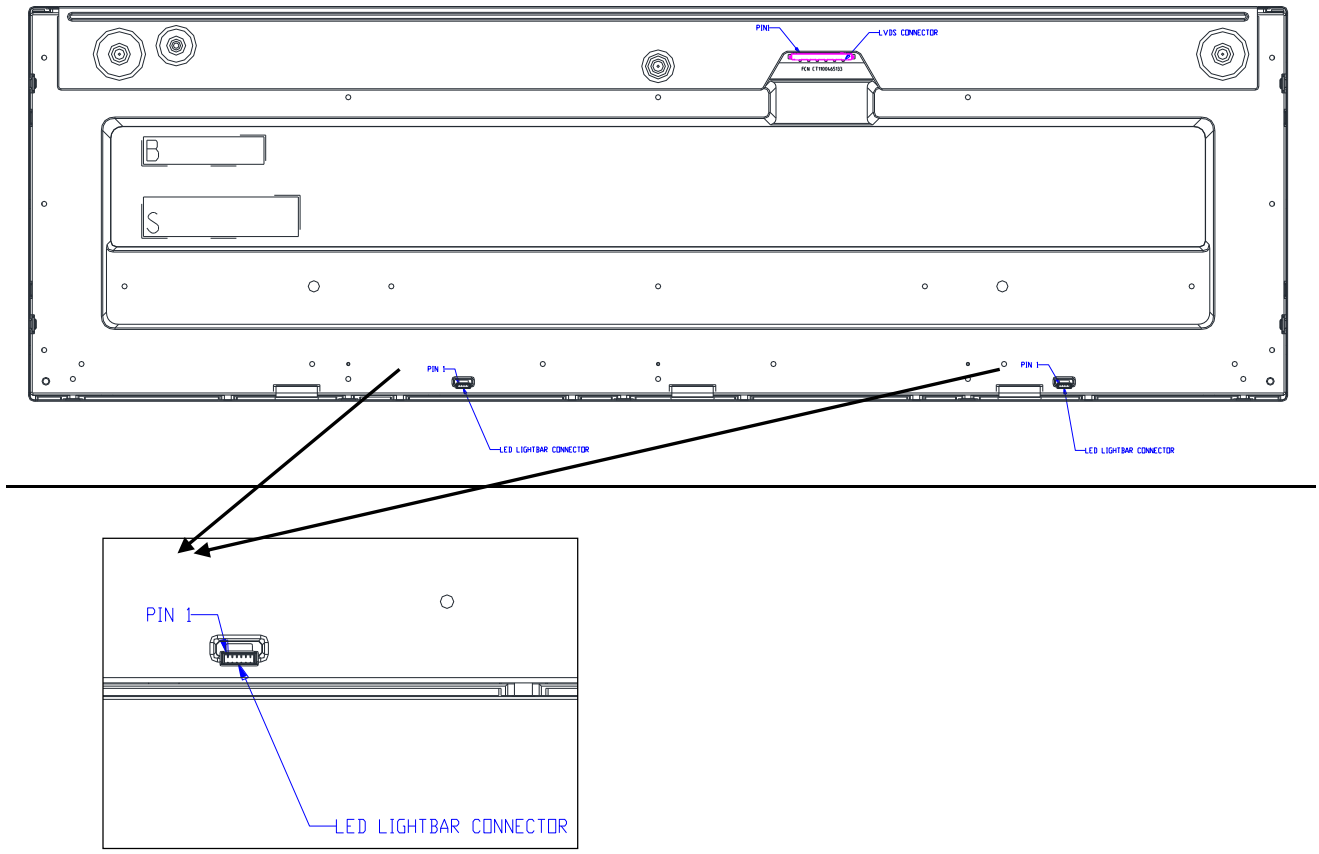
Note 3: Definition of life time: Brightness becomes to 50% of its original value. The minimum life time of LED unit is on the condition of I<sub>F</sub> = 95 mA and 25±2°C (Room Temperature).

Note 4: If module is driven by high current or at high ambient temperature & humidity condition. The operating life will be reduced.

### 4.2 Input Pin Assignment

Connector Name / Designation	LED Connector
Manufacturer	ENTRY
Connector Model Number	ENTRY 3707K-S06N-01L
Mating Housing Part Number	ENTRY H112K-D06N-21B or compatible

PIN #	SIGNAL NAME	DESCRIPTION
1	VLED+	Positive of LED String
2	VLED+	
3	N1	Negative of LED String
4	N2	
5	N3	
6	N4	

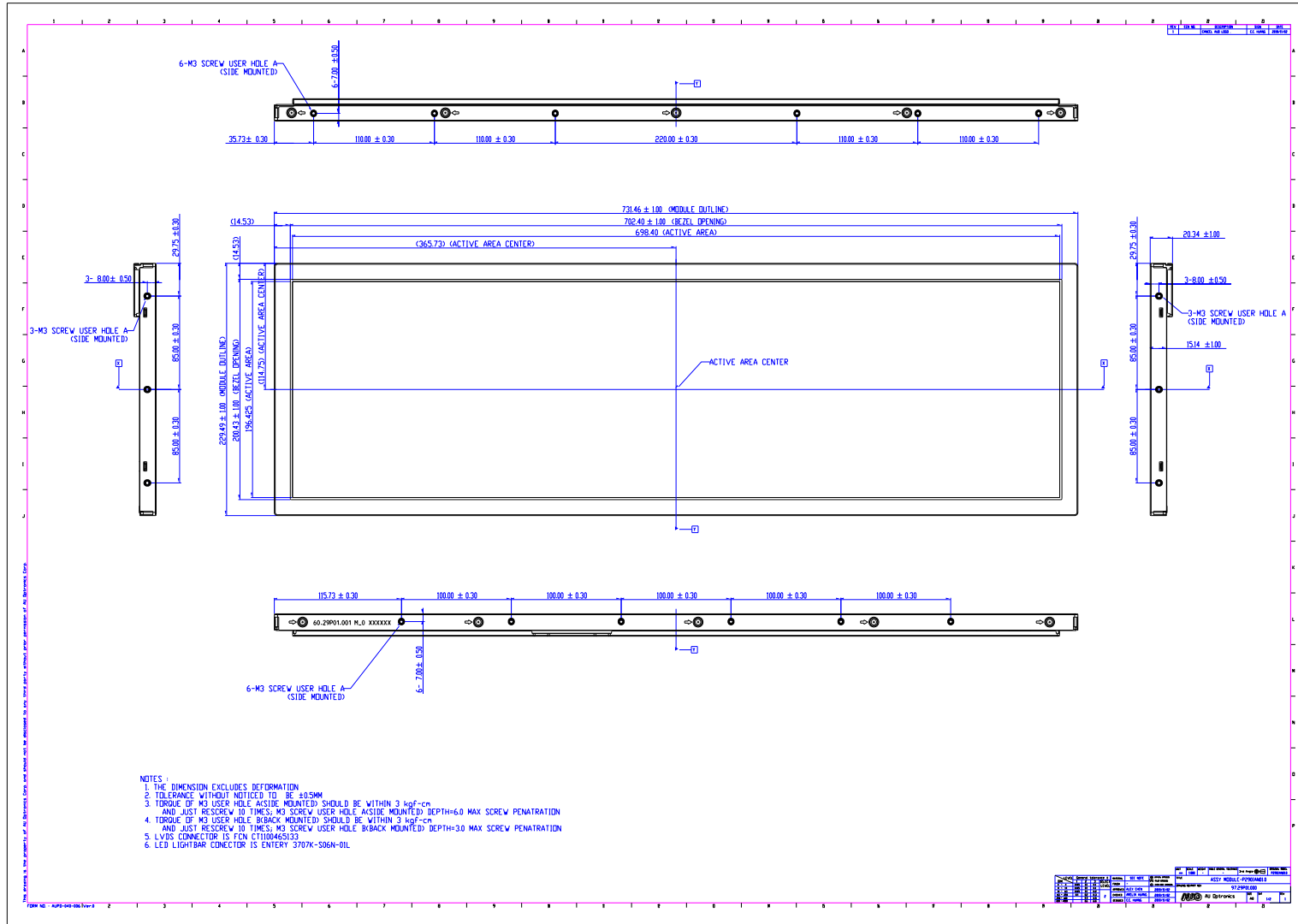


## 5. Mechanical Characteristics

The contents provide general mechanical characteristics for the model P290IAN01.0. In addition the figures in the next page are detailed mechanical drawing of the LCD.

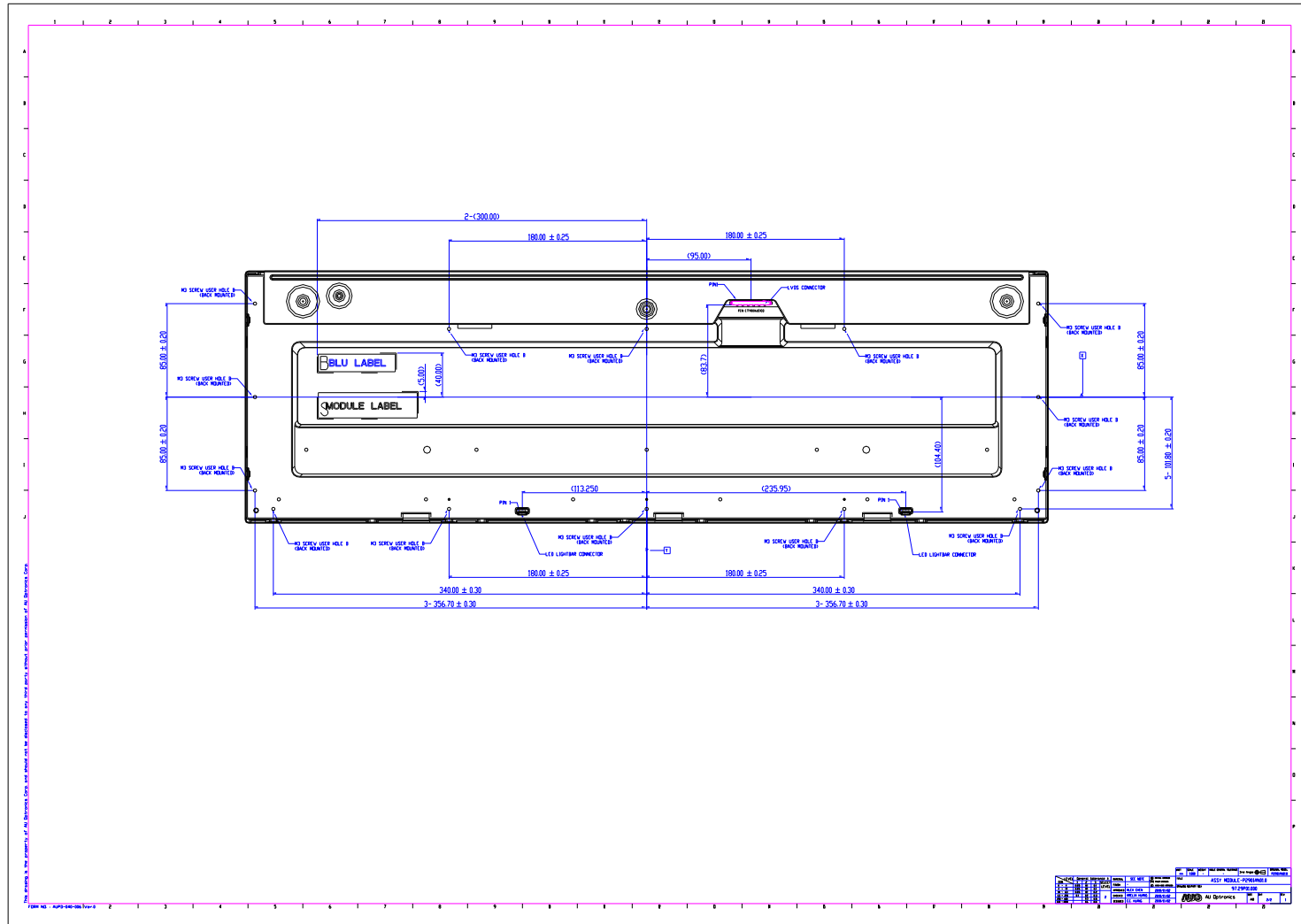
Outline Dimension	Horizontal (typ.)	731.46mm
	Vertical (typ.)	229.49mm
	Depth (min.)	20.34mm
Bezel Opening Area	Horizontal (typ.)	702.4mm
	Vertical (typ.)	200.43 mm
Active Display Area	Horizontal	698.4 mm
	Vertical	196.425 mm
Weight	2,700(g)	

**Front View**





**Rear View**



## 6. Reliability Test Items

	Test Item	Q'ty	Condition
1	High temperature storage test	3	60°C, 500hrs
2	Low temperature storage test	3	-20°C, 500hrs
3	High temperature operation test	3	50°C, 500hrs
4	Low temperature operation test	3	-10°C, 500hrs
5	Vibration test (non-operation)	3	Wave form: random Vibration level: 1.0G RMS Bandwidth: 10-300Hz, Duration: X, Y, Z 10min per axes X,Y,Z : Vertical
6	Shock test (non-operation)	3	Shock level: 50G ( $\pm X$ , $\pm Y$ ) Waveform: half sine wave, 20ms Direction: $\pm X$ , $\pm Y$ , $\pm Z$ , One time each direction
7	Vibration test (With carton)	1 (PKG)	Random wave (1.04G RMS, 2-200Hz) 20 mins per each X,Y,Z axes
8	Drop test (With carton)	1 (PKG)	Drop Height: 61.0 cm, Surround four flats and bottom flat twice (ASTMD5276)

## **7. International Standard**

### **7.1 Safety**

- (1) UL 60950-1 Second Edition, Standard for Safety of Information Technology Equipment Including electrical Business Equipment.
- (2) IEC 60950-1: 2005 + A1: 2009 + A2: 2003, Standard for Safety of International Electro technical Commission.
- (3) EN 60950-1: 2006+A11: 2009 + A1: 2010 + A12: 2011 + A2: 2013, European Committee for Electro technical Standardization (CENELEC), EUROPEAN STANDARD for Safety of Information Technology Equipment Including Electrical Business Equipment

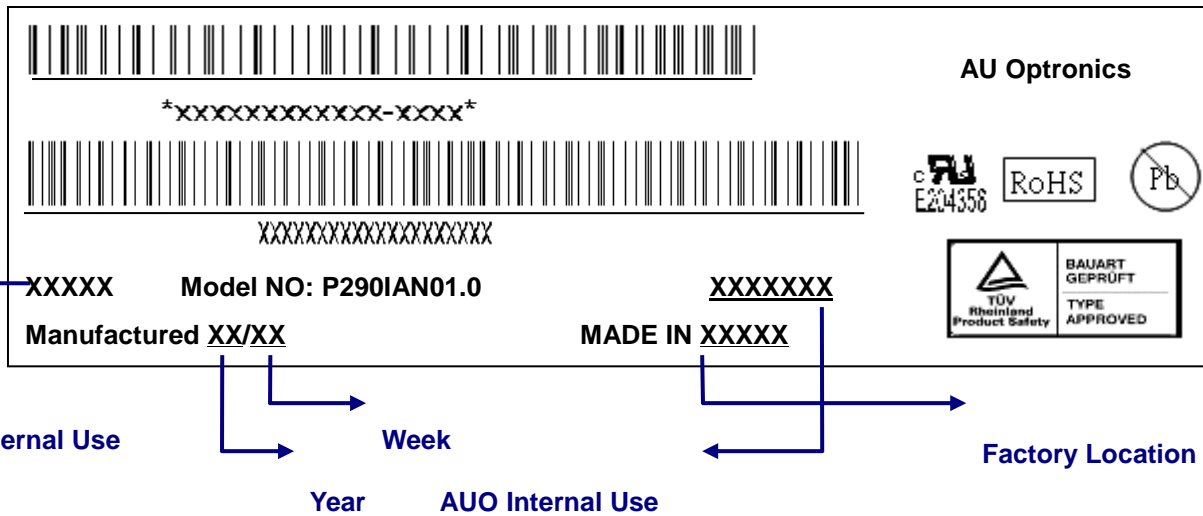
### **7.2 EMC**

- (1) ANSI C63.4 "Methods of Measurement of Radio-Noise Emissions from Low-Voltage Electrical and Electrical Equipment in the Range of 9kHz to 40GHz." American National standards Institute(ANSI), 1992
- (2) C.I.S.P.R "Limits and Methods of Measurement of Radio Interface Characteristics of Information Technology Equipment." International Special committee on Radio Interference.
- (3) EN 55022 "Limits and Methods of Measurement of Radio Interface Characteristics of Information Technology Equipment." European Committee for Electro technical Standardization. (CENELEC), 1998



## 8. Packing

### 8.1 DEFINITION OF LABEL:

#### A. Panel Label:

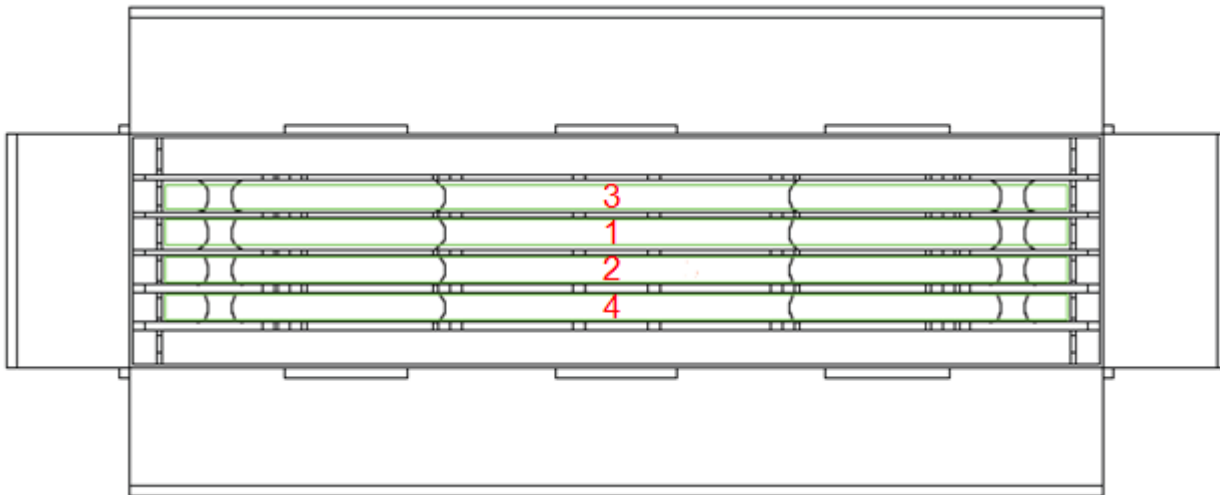


#### Green mark description

- (1) For Pb Free Product, AUO will add  for identification.
  - (2) For RoHs compatible products, AUO will add  for identification.
- Note: The green Mark will be present only when the green documents have been ready by AUO internal green team. (definition of green design follows the AUO green design checklist.)

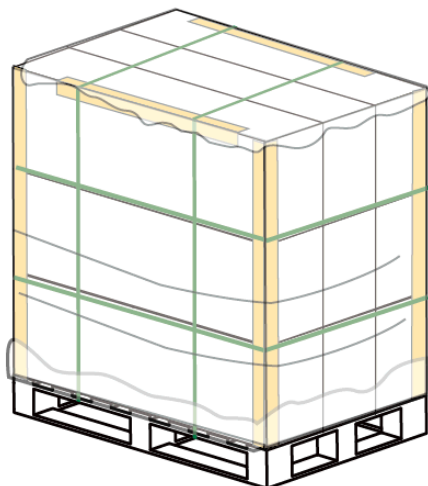
#### B. Carton Package

- (1) The outside dimension of carton is 810 x 210x 430 (mm).
- (2) 4 pieces per carton box.
- (3) 1\*5 boxes per layer. By air, 3 layer / pallet. By sea, refer packing documents. Pallet size (not include carton boxes): 1150 mm \* 840 mm \* 135 mm

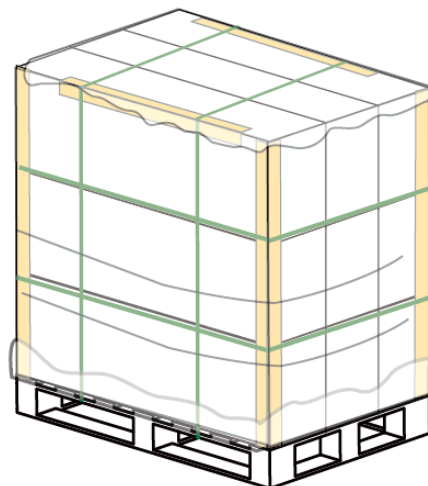


**8.2 Pallet and Shipment Information**

	Item	Specification			Packing Remark
		Qty.	Dimension	Weight (kg)	
1	Packing Box	4pcs/box	806(L)mm*206(W)mm*315(H)mm	13.5	
2	Pallet	1	1150(L)mm*840(W)mm*132(H)mm	15	
3	Boxes per Pallet	20 boxes/Pallet (By Air) ; (20+10) Boxes/Pallet (By Sea)			
4	Panels per Pallet	80 pcs/pallet(By Air) ; 120 pcs/Pallet (By Sea)			
5	Pallet after packing	20(by Air)	1150(L)mm*840(W)mm*1392(H)mm (by Air)	285(by Air)	
		30(by Sea)	1150(L)mm*840(W)mm*2154(H)mm (by Sea)	435(by Sea)	40ft / Double Pallet



Note:For Air Freight



Note:For 20'/40' DC & HQ Container

## 9. PRECAUTIONS

Please pay attention to the followings when you use this TFT LCD module.

### **9.1 MOUNTING PRECAUTIONS**

- (1) You must mount a module using holes arranged in four corners or four sides.
- (2) You should consider the mounting structure so that uneven force (ex. twisted stress) is not applied to module. And the case on which a module is mounted should have sufficient strength so that external force is not transmitted directly to the module.
- (3) Please attach the surface transparent protective plate to the surface in order to protect the polarizer. Transparent protective plate should have sufficient strength in order to resist external force.
- (4) You should adopt radiation structure to satisfy the temperature specification.
- (5) Acetic acid type and chlorine type materials for the cover case are not desirable because the former generates corrosive gas of attacking the polarizer at high temperature and the latter cause circuit broken by electro-chemical reaction.
- (6) Do not touch, push or rub the exposed polarizer with glass, tweezers or anything harder than HB pencil lead. And please do not rub with dust clothes with chemical treatment. Do not touch the surface of polarizer for bare hand or greasy cloth. (Some cosmetics are detrimental to the polarizer.)
- (7) When the surface becomes dusty, please wipe gently with absorbent cotton or other soft materials like chamois soaks with petroleum benzene. Normal-hexane is recommended for cleaning the adhesives used to attach front/ rear polarizer. Do not use acetone, toluene and alcohol because they cause chemical damage to the polarizer.
- (8) Wipe off saliva or water drops as soon as possible. Their long time contact with polarizer causes deformations and color fading.
- (9) Do not open the case because inside circuits do not have sufficient strength.

### **9.2 OPERATING PRECAUTIONS**

- (1) The device listed in the product specification sheets was designed and manufactured for PID application
- (2) The spike noise causes the miss-operation of circuits. It should be lower than following voltage:  
 $V = \pm 200\text{mV}$  (Over and under shoot voltage)
- (3) Response time depends on the temperature. (In lower temperature, it becomes longer..)
- (4) Brightness of LED depends on the temperature. (In lower temperature, it becomes lower.) And in lower temperature, response time (required time that brightness is stable after turned on) becomes longer.
- (5) Be careful for condensation at sudden temperature change. Condensation makes damage to polarizer or electrical contacted parts. And after fading condensation, smear or spot will occur.
- (6) When fixed patterns are displayed for a long time, remnant image is likely to occur.
- (7) Module has high frequency circuits. Sufficient suppression to the electromagnetic interference shall be done by system manufacturers. Grounding and shielding methods may be important to minimize the interface.

### **9.3 Operating Condition for Public Information Display**

The device listed in the product specification is designed and manufactured for PID (Public Information Display) application. To optimize module's lifetime and function, below operating usages are required.

(1) Normal operating condition

1. Operating temperature: 0~50°C
2. Operating humidity: 10~90%
3. Display pattern: dynamic pattern (Real display).

Note) Long-term static display would cause image sticking.

(2) Operation usage to protect against image sticking due to long-term static display.

1. Suitable operating time: 24 hours a day or less.  
(\* The moving picture can be allowed for 24 hours a day)
2. Liquid Crystal refresh time is required. Cycling display between 5 minutes' information (static) display and 10 seconds' moving image.
3. Periodically change background and character (image) color.
4. Avoid combination of background and character with large different luminance.

(3) Periodically adopt one of the following actions after long time display.

1. Running the screen saver (motion picture or black pattern)
2. Power off the system for a while

(4) LCD system is required to place in well-ventilated environment. Adapting active cooling system is highly recommended.

(5) Product reliability and functions are only guaranteed when the product is used under right operation usages. If product will be used in extreme conditions, such as high temperature/ humidity, display stationary patterns, or long operation time etc..., it is strongly recommended to contact AUO for filed application engineering advice. Otherwise, its reliability and function may not be guaranteed. Extreme conditions are commonly found at airports, transit stations, banks, stock market and controlling systems.

### **9.4 Electrostatic Discharge Control**

Since a module is composed of electronic circuits, it is not strong to electrostatic discharge. Make certain that treatment persons are connected to ground through wristband etc. And don't touch interface pin directly.

### **9.5 Precautions for Strong Light Exposure**

Strong light exposure causes degradation of polarizer and color filter.

### **9.6 Storage**

When storing modules as spares for a long time, the following precautions are necessary.

- (1) Store them in a dark place. Do not expose the module to sunlight or fluorescent light. Keep the temperature between 5°C and 35°C at normal humidity.
- (2) The polarizer surface should not come in contact with any other object. It is recommended that they

be stored in the container in which they were shipped.

- (3) Storage condition is guaranteed under packing conditions.
- (4) The phase transition of Liquid Crystal in the condition of the low or high storage temperature will be recovered when the LCD module returns to the normal condition.

**9.7 Handling Precautions for Protection Film**

- (1) The protection film is attached to the bezel with a small masking tape. When the protection film is peeled off, static electricity is generated between the film and polarizer. This should be peeled off slowly and carefully by people who are electrically grounded and with well ion-blown equipment or in such a condition, etc.
- (2) When the module with protection film attached is stored for a long time, sometimes there remains a very small amount of glue still on the bezel after the protection film is peeled off.
- (3) You can remove the glue easily. When the glue remains on the bezel or its vestige is recognized, please wipe them off with absorbent cotton waste or other soft material like chamois soaked with normal-hexane.

**9.8 Dust Resistance**

- (1) AUO module dust test is conducted with marked holes (see Figure) sealed to comply with JIS D0207 .
- (2) Module users should design set with these holes used/sealed(if not used) or covered by set mechanism to prevent dust from entering. The AUO testing procedure cannot replicate all different real world scenarios, module users should apply set dust resistance solution to meet users' requirement.

