



RVT70HSHFWCA0

HB, IPS 7.0" HDMI LCD TFT DATASHEET

Rev.1.6

2022-12-14

| ITEM | CONTENTS | UNIT |
|--------------------------------|---|-------------------|
| LCD Type | TFT/Transmissive/Normally Black/IPS | / |
| Size | 7.0 | Inch |
| Viewing Direction | Free | / |
| Outside Dimensions (W x H x D) | 181.60 x 100.60 x 25.28 | mm |
| Active Area (W x H) | 154.21 x 85.92 | mm |
| Pixel Pitch (W x H) | 0.1506 x 0.1432 | mm |
| Resolution | 1024 (RGB) x 600 | / |
| Brightness | 800 | cd/m ² |
| Color Depth | 16.7 M | / |
| Pixel Arrangement | RGB Vertical Stripe | / |
| Controller of the Main Board | RTD2660H | / |
| Video Interface | HDMI | / |
| With/Without Touch | With Projected Capacitive Touch Panel | / |
| CTP Driver | ILI2132A | / |
| Touch Panel Interface | USB-C | / |
| Power Supply | Power Jack (DC 7.0V - 30.0 V), USB-C | V |
| Weight | 279 | g |

Note 1. RoHS3 compliant

Note 2. LCM weight tolerance: $\pm 5\%$



1. REVISION RECORD

| REV NO. | REV DATE | CONTENTS | REMARKS |
|---------|------------|--|---------|
| 1.0 | 2021-03-10 | Initial Release | |
| 1.1 | 2021-04-16 | HDMI board picture updated | |
| 1.2 | 2021-07-21 | Correction of J5 connector description | |
| 1.3 | 2021-08-05 | Updating new template Correction of external keyboard connector pinout | |
| 1.4 | 2022-01-13 | Updating the dip switches on the drawing. | |
| 1.5 | 2022-02-02 | Correct the description of DC1 from 7.0 V-14.0V to 7.0V- 30.0V | |
| 1.6 | 2022-12-14 | Update 2 parameters of Backlight PWM & power - J5 <ul style="list-style-type: none">• Clarify PWM frequency range: 1kHz-10kHz• Clarify the power input voltage range for pin5, 6 (VDD) Monitor controller is upgraded from RTD2662 to RTD2660H | |



2. CONTENTS

| | | |
|------|---|----|
| 1. | REVISION RECORD..... | 2 |
| 2. | CONTENTS..... | 3 |
| 3. | MODULE CLASSIFICATION INFORMATION..... | 4 |
| 4. | ASSEMBLY GUIDE..... | 5 |
| 4.1 | Mounting frame..... | 5 |
| 5. | MODULE DRAWING..... | 6 |
| 6. | ABSOLUTE MAXIMUM RATINGS..... | 7 |
| 7. | ELECTRICAL CHARACTERISTICS..... | 7 |
| 8. | BACKLIGHT DRIVING CONDITIONS..... | 7 |
| 9. | ELECTRO-OPTICAL CHARACTERISTICS..... | 8 |
| 10. | INTERFACE DESCRIPTION..... | 10 |
| 10.1 | PCB overview..... | 10 |
| 10.2 | Power connector -DC1..... | 11 |
| 10.3 | HDMI connector -JP5..... | 11 |
| 10.4 | Touch panel connector -USB-C..... | 11 |
| 10.5 | Light sensor connector – RT1..... | 12 |
| 10.6 | Backlight PWM &Power -J5..... | 12 |
| 10.7 | UART connector -J2..... | 13 |
| 10.8 | External Keyboard connector - J1..... | 13 |
| 11. | DISPLAY SPECIFICATION..... | 13 |
| 12. | CAPACITIVE TOUCH SCREEN PANLE SPECIFICATIONS..... | 13 |
| 12.1 | Mechanical characteristics..... | 13 |
| 12.2 | Electrical characteristics..... | 14 |
| 13. | INSPECTION..... | 14 |
| 13.1 | Inspection condition..... | 14 |
| 13.2 | Inspection standard..... | 15 |
| 14. | RELIABILITY TEST..... | 16 |
| 15. | LEGAL INFORMATION..... | 17 |



3. MODULE CLASSIFICATION INFORMATION

| RV | T | 70 | H | S | H | F | W | C | A0 |
|----|----|----|----|----|----|----|----|----|-----|
| 1. | 2. | 3. | 4. | 5. | 6. | 7. | 8. | 9. | 10. |

| NO. | PARAMETER | SYMBOL |
|-----|------------------|---------------------------------|
| 1. | BRAND | RV – Riverdi |
| 2. | PRODUCT TYPE | T – TFT Standard |
| 3. | DISPLAY SIZE | 70 – 7.0” |
| 4. | MODEL SERIAL NO. | H – High Brightness, IPS |
| 5. | RESOLUTION | S – 1024 x 600 px |
| 6. | INTERFACE | H – HDMI |
| 7. | FRAME | F – With Mounting Metal Frame |
| 8. | BACKLIGHT TYPE | W – LED White |
| 9. | TOUCH PANEL | C – With Capacitive Touch Panel |
| 10. | VERSION | A0 – aTouch |

4. ASSEMBLY GUIDE

4.1 Mounting frame

For dimensions 3.5", 4.3", 5.0", 7.0" and 10.1", the product with mounting frame version is available. Thanks to the four catches attached to the side, frame provides strong assembly to the surface by mounting element (like the screw, see Figure 1). The frames are specially designed to fit Riverdi products perfectly. The diameter of the mounting hole is 3.5mm.

Figure 1. Mounting frame

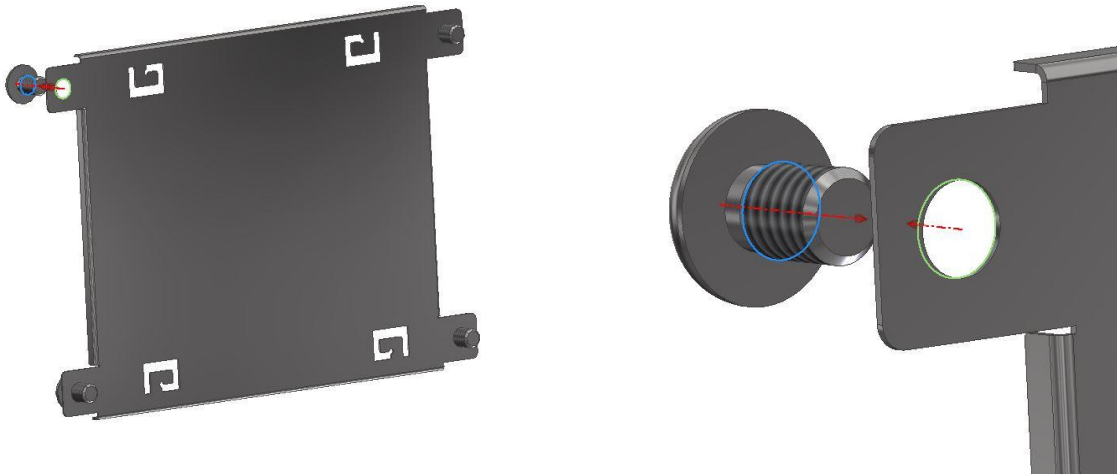

| Revision: | Changes: | Date: |
|-----------|---|------------|
| 1.0 | Initial Case | 2021.03.08 |
| 1.1 | Adding Inch Unit | 2021.08.25 |
| 1.2 | PCB Update-Change the touch ZIF connector | 2021.08.26 |
| 1.3 | PCB Update And Dimensions Overhaul | 2021.01.05 |

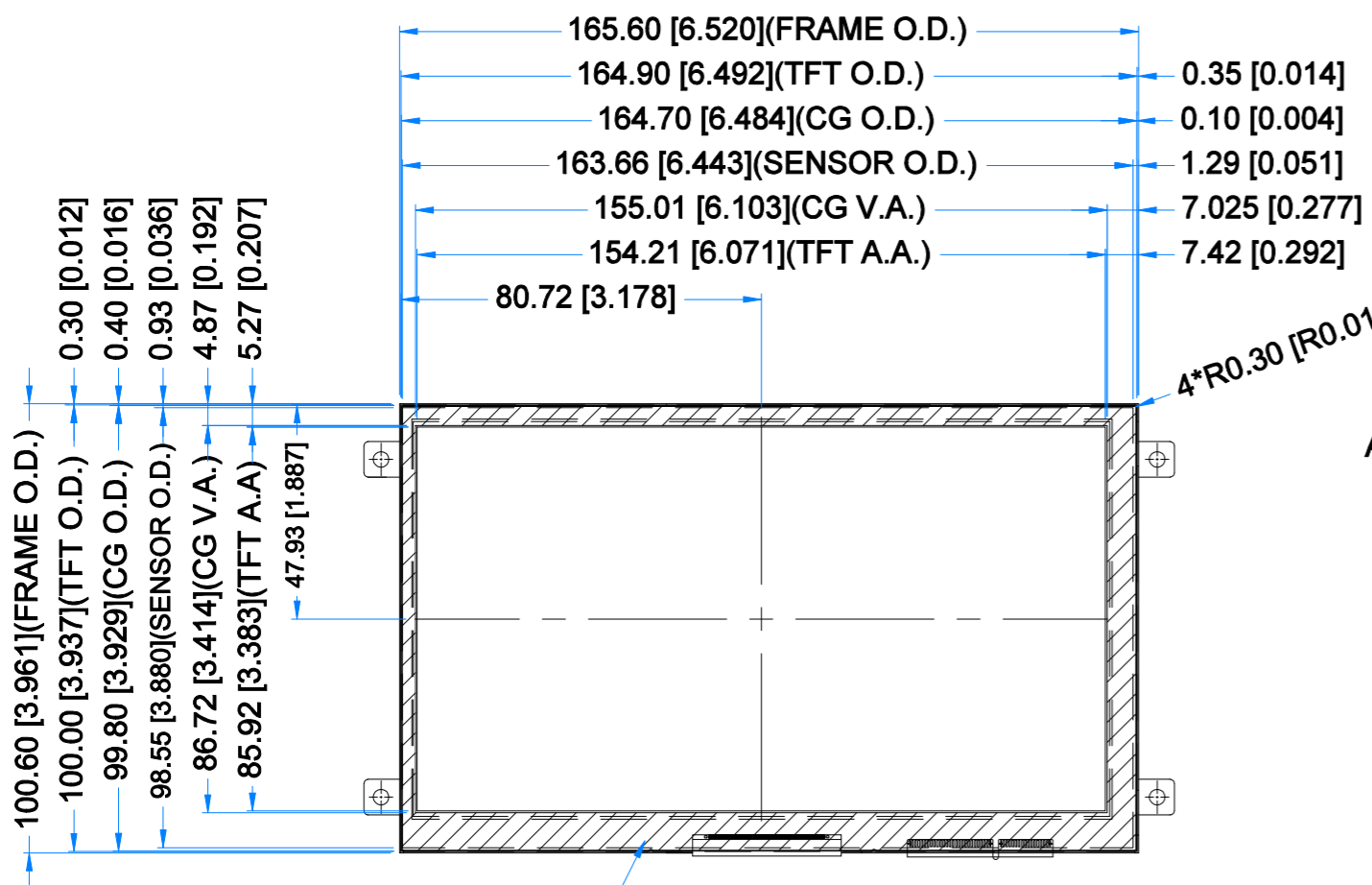

BLACK MASK PRINTING
RAL9005

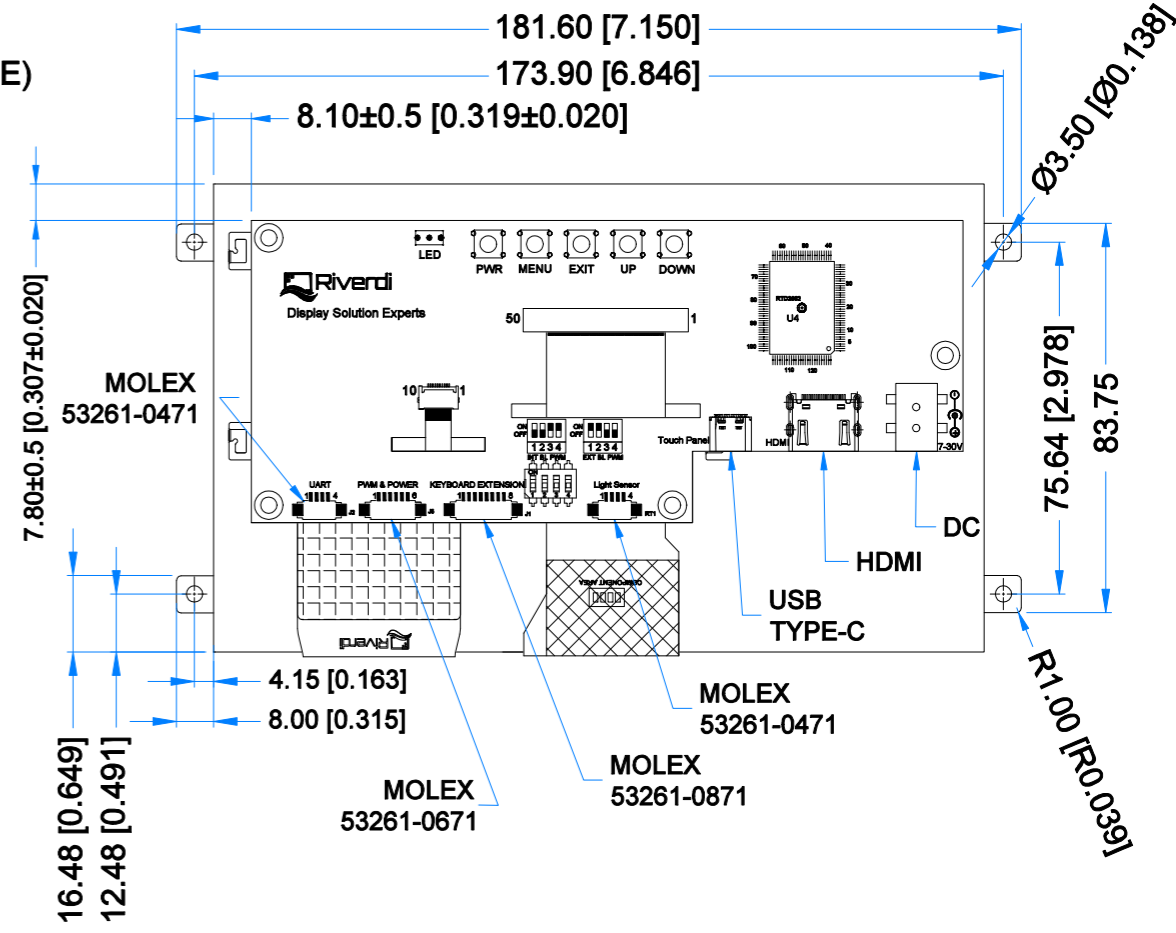
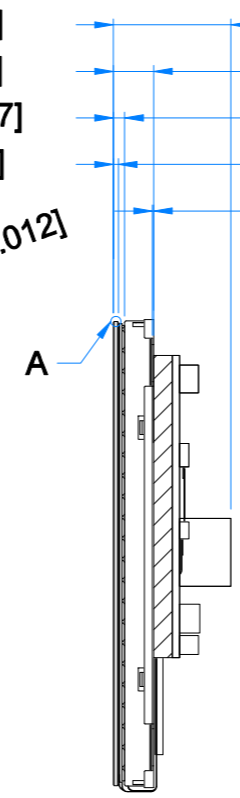

DETAIL A
SCALE 4:1

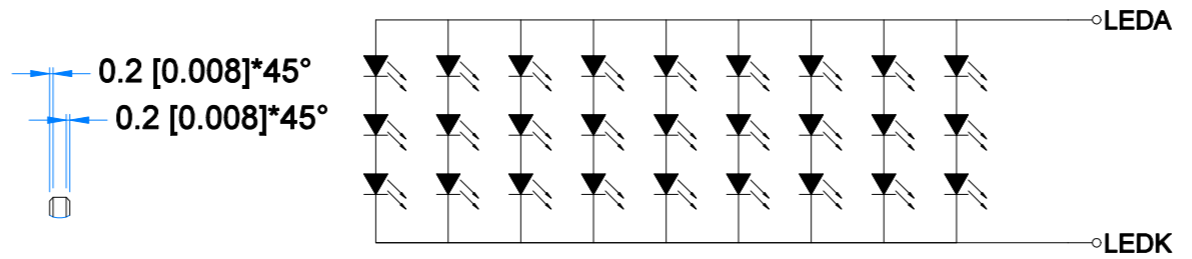

LED Diagram Circuit

LCM NOTES:
1. LCD TYPE: TRANSMISSIVE, NORMALLY BLACK, IPS
2. RESOLUTION: 1024x600
3. VIEWING ANGLE: FREE
4. MODULE SURFACE LUMINANCE: MAX. 800 cd/m²
5. CONTROLLER IC OF MAIN BOARD: RTD2662
6. VIDEO INTERFACE: HDMI
7. POWER SUPPLY: POWER JACK (7.0-30.0V); USB-C

TP NOTES:
1. TP STRUCTURE: G+G
2. CG THICKNESS: 1.10 mm
3. DRIVER IC: ILI2132A
4. TOUCH PANEL INTERFACE: USB-C

GENERAL NOTES:
1. OPERATING TEMPERATURE: -20°C ~ 70°C
2. STORAGE TEMPERATURE: -30°C ~ 80°C
3. WITHOUT INDIVIDUAL TOLERANCE: ±0.3mm
4. RoHS3 COMPLIANT

| | | | |
|--------------------|------------|--------|--|
| PN: RVT70HSHFWCA0 | | | |
| SN: | | | |
| DRAWN: M.Natywa | 2022.01.05 | 1:1.63 | |
| CHECKED: Carol Gao | 2022.01.13 | [mm] | |
| APPR: | | ISO A3 | |



6. ABSOLUTE MAXIMUM RATINGS

| PARAMETER | SYMBOL | MIN | MAX | UNIT |
|---|-----------------|-----|------|------|
| Supply Voltage for Module | VDD | 7.0 | 30.0 | V |
| Operating Temperature | T _{OP} | -20 | 70 | °C |
| Storage Temperature | T _{ST} | -30 | 80 | °C |
| Storage Humidity (@ 25 ± 5°C) | H _{ST} | 10 | 90 | % RH |
| Operating Ambient Humidity (@ 25 ± 5°C) | H _{OP} | 10 | 90 | % RH |

Note. Exceeding maximum values may cause operation or damage to the unit.

7. ELECTRICAL CHARACTERISTICS

| PARAMETER | SYMBOL | MIN | TYP | MAX | UNIT | NOTE |
|---------------------------|--------|-----|------|------|------|------|
| Supply Voltage for Module | VDD | 7.0 | 12.0 | 30.0 | V | |

| PARAMETER | SYMBOL | BL 0% | BL 50% | BL 100% | UNIT | NOTE |
|-------------------------------|--------------------|-------|--------|---------|------|-----------|
| Current Drawn from VDD@7.0V | I _{VDD} | 291 | 496 | 748 | mA | Note 1 |
| Current Drawn from VDD@12.0V | | 172 | 289 | 428 | | |
| Current Drawn from VDD @24.0V | | 93 | 152 | 220 | | |
| Current Drawn from VDD @30.0V | | 74 | 124 | 178 | | |
| Current drawn from USB-C | I _{USB-C} | 366 | 692 | 1156 | | Note 1, 2 |

Note 1. BL 0% Current was measured with BL brightness set to 0%,
 BL 50% current was measured with BL brightness set to 50%,
 BL 100% current was measured with BL brightness set to 100%.
 Test condition: Ambient temp 25 °C PCAP is on Active mode

Note 2. USB-C interface can be used as a power supply for all modules with or without touch panels. If DC1 power jack is used, the power from the USB-C connector is not drawn, as the onboard MOSFET key cuts it off.

8. BACKLIGHT DRIVING CONDITIONS

| PARAMETER | SYMBOL | MIN | TYP | MAX | UNIT | NOTE |
|-----------------------------|-----------------|-----|--------|-----|-------|----------------|
| Backlight Power Consumption | W _{BL} | - | 2592 | - | mW | 100% backlight |
| Lifetime | - | - | 50,000 | - | hours | Note |

Note. Operating life means the period in which the LED brightness goes down to 50% of the initial brightness. Typical operating lifetime is the estimated parameter.



9. ELECTRO-OPTICAL CHARACTERISTICS

Optical characteristics are determined after the unit has been 'ON' and stable for approximately 30 minutes in a dark environment at 25 °C. The values specified are at an approximate distance 500mm from the LCD surface at a viewing angle of Φ and θ equal to 0°.

| ITEM | SYMBOL | CONDITION | MIN | TYP | MAX | UNIT | RMK | NOTE |
|----------------------------|-------------------|--|-------|-------|-------|-------------------|--------|------|
| Response Time | Tr+Tf | $\theta=0^\circ$ $\phi=0^\circ$ Ta=25 °C | - | 35 | - | ms | FIG 2. | 4 |
| Contrast Ratio | Cr | | - | 800 | - | --- | FIG 3. | 1 |
| Luminance Uniformity | δ WHITE | | - | 75 | - | % | | 3 |
| Surface Luminance | Lv | | - | 800 | - | cd/m ² | | 2 |
| Viewing Angle Range | θ | $\phi = 90^\circ$ | - | 85 | - | deg | FIG 4. | 6 |
| | | $\phi = 270^\circ$ | - | 85 | - | deg | | |
| | | $\phi = 0^\circ$ | - | 85 | - | deg | | |
| | | $\phi = 180^\circ$ | - | 85 | - | deg | | |
| CIE (x, y) Chromaticity | Rx | $\theta=0^\circ$ $\phi=0^\circ$ Ta=25 °C | 0.578 | 0.618 | 0.658 | - | FIG 3. | 5 |
| | Ry | | 0.489 | 0.329 | 0.369 | - | | |
| | Gx | | 0.376 | 0.416 | 0.456 | - | | |
| | Gy | | 0.493 | 0.533 | 0.573 | - | | |
| | Bx | | 0.071 | 0.111 | 0.151 | - | | |
| | By | | 0.108 | 0.148 | 0.188 | - | | |
| | Wx | | 0.270 | 0.310 | 0.350 | - | | |
| | Wy | | 0.290 | 0.330 | 0.370 | - | | |

Note 1. Contrast Ratio (CR) is defined mathematically as below, for more information see Figure 3.

$$\text{Contrast Ratio} = \frac{\text{Average Surface Luminance with all white pixels (P1, P2, P3, P4, P5)}}{\text{Average Surface Luminance with all black pixels (P1, P2, P3, P4, P5)}}$$

Note 2. Surface luminance is the LCD surface from the surface with all pixels displaying white at 100% backlight. For more information see Figure 3.

$$Lv = \text{Average Surface Luminance with all white pixels (P1, P2, P3, P4, P5)}$$

Note 3. The uniformity in surface luminance δ WHITE is determined by measuring luminance at each test position 1 through 5, and then dividing the minimum luminance of 5 points luminance by maximum luminance of 5 points luminance. For more information see Figure 3.

$$\delta \text{ WHITE} = \frac{\text{Minimum Surface Luminance with all white pixels (P1, P2, P3, P4, P5)}}{\text{Maximum Surface Luminance with all white pixels (P1, P2, P3, P4, P5)}}$$

Note 4. Response time is the time required for the display to transition from white to black (Rise Time, Tr) and from black to white (Decay Time, Tf). For additional information see Figure 2. The test equipment is BM-7A.

Note 5. CIE (x, y) chromaticity, the x, y value is determined by measuring luminance at each test position 1 through 5, and then calculating the average value.

Note 6. For TFT module the contrast ratio is greater than 10. The angles are determined for the horizontal or x axis and the vertical or y axis with respect to the z axis which is normal to LCD surface. For more information see Figure 4.

Note 7. Viewing angle is measured at the center point of the LCD by CONOSCOPE (ergo-80). For response time testing, the testing data is based on BM-7A. Instruments for Contrast Ratio, Surface Luminance, Luminance Uniformity, Chromaticity the test data is based on SR-3A.

Figure 2. The definition of response time

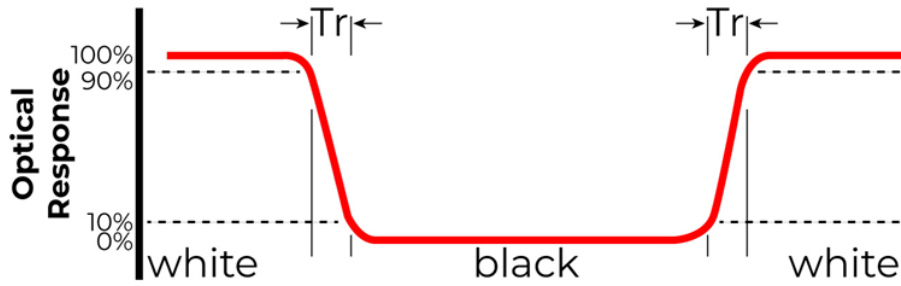

Figure 3. Measuring method for Contrast ratio, surface luminance, Luminance uniformity, CIE (x, y) chromaticity

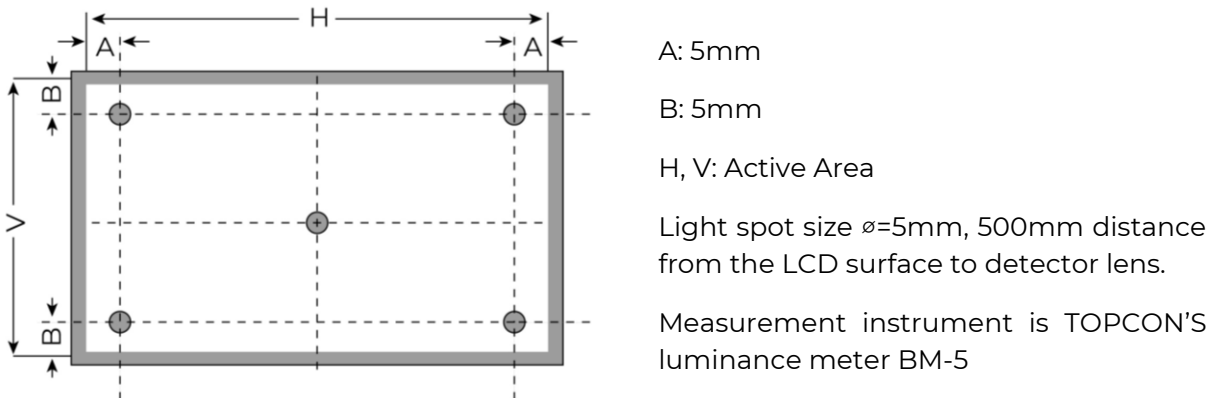
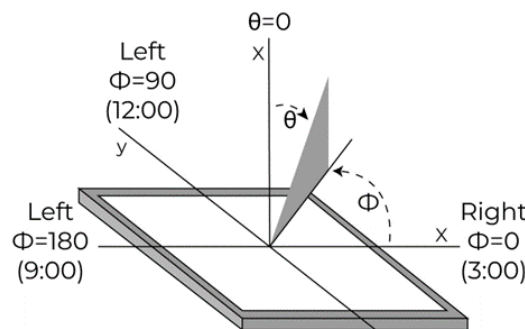

Figure 4. The definition of viewing angle



10. INTERFACE DESCRIPTION

10.1 PCB overview

Picture below shows the connectors exact placement and their descriptions.

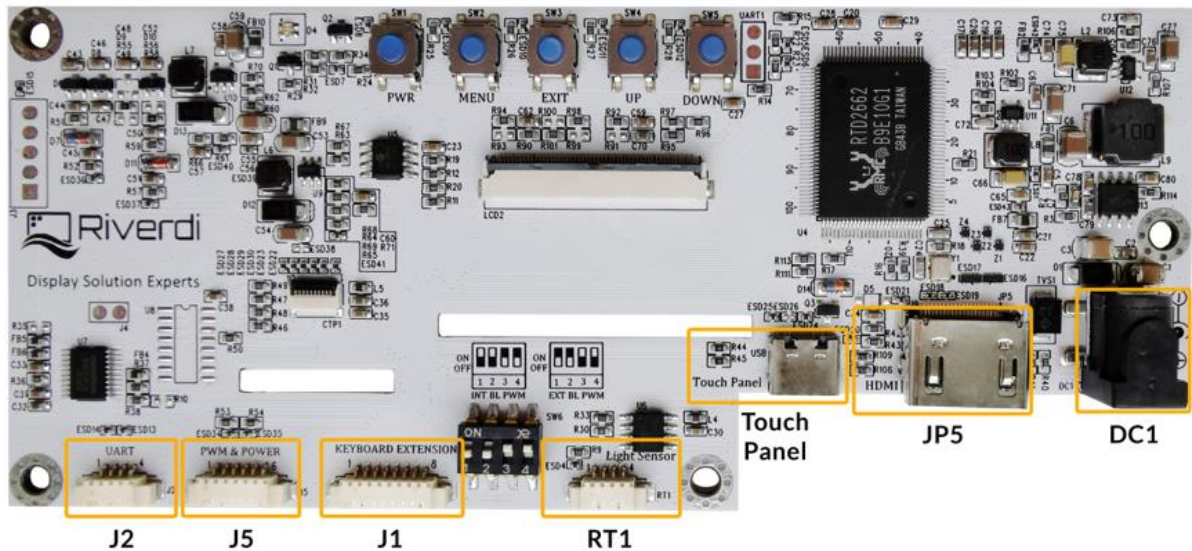

| NAME | CONNECTOR | DESCRIPTION | NOTE |
|-------------|-----------------------------|--|--------|
| DC1 | Power Jack | DC jack, (5.5 mm OD; 2.1mm ID) This is the connector to power on the TFT module. It allows DC for voltage range from 7.0V to 30.0V | |
| JP5 | HDMI connector | This is the connector to which you can connect the HDMI signal source to the module. | |
| Touch Panel | USB-C | Touch panel interface for module with touch panel. Also, the USB-C can be used as a power supply for all modules with or without touch panels. | |
| J1 | External keyboard connector | Molex 53261-0871 or alternative; Horizontal, 1.25mm pitch; 8 pins. The connector is reserved for external keyboard. Performs the same functions: PWR, MENU, EXIT, UP, DOWN as the pushbuttons on PCB. | Note 1 |
| J5 | Backlight PWM & Power | Molex 53261-0671 or alternative; Horizontal, 1.25mm pitch; 6 pins. The unit realizes the function of digital dimming. This connector enables to control backlight PWM externally. | Note 2 |
| J2 | UART | Molex 53261-0471 or alternative; Horizontal, 1.25mm pitch; 4 pins. It supports asynchronous serial communication UART port. | Note 3 |
| RT1 | Light sensor | Molex 53261-0471 or alternative; Horizontal, 1.25mmpitch; 4 pins. To connect external light sensor | Note 1 |



Note 1. Light sensor and external keyboard are optional, not included in the standard kit.

Note 2. 4 position-DIP onboard switch SW6 is used to choose the power to backlight. The settings are:

INTERNAL BL PWM: Set 1&2 to OFF, and 3&4 to ON,

EXTERNAL BL PWM: Set 1&2 to ON, and 3&4 to OFF.

Note 3. UART functionality is under development process.

10.2 Power connector -DC1

| PIN NO. | SYMBOL | DESCRIPTION |
|---------|--------|-----------------|
| 1 | VDD | Power supply DC |
| 2 | GND | GND |

10.3 HDMI connector -JP5

| PIN NO. | SYMBOL | DESCRIPTION |
|---------|--------------------|---------------------------------|
| 1 | TMDS Data 2+ | TMDS differential signal 2+ |
| 2 | TMDS Data2 Shield | Data2 shielding ground |
| 3 | TMDS Data 2- | TMDS differential signal 2- |
| 4 | TMDS Data 1+ | TMDS differential signal 1+ |
| 5 | TMDS Data1 Shield | Data1 shielding ground |
| 6 | TMDS Data 1- | TMDS differential signal 1- |
| 7 | TMDS Data 0+ | TMDS differential signal 0+ |
| 8 | TMDS Data 0 Shield | Data0 shielding ground |
| 9 | TMDS Data 0- | TMDS differential signal 0- |
| 10 | TMDS Data Clock+ | TMDS differential signal Clock+ |
| 11 | TMDS Data Shield | Clock shielding ground |
| 12 | TMDS Data Clock- | TMDS differential signal Clock- |
| 13 | CEC | Electronic protocol CEC |
| 14 | NC | No Connection |
| 15 | SCL | I ² C clock Line |
| 16 | SDA | I ² C data Line |
| 17 | DDC/CEC GND | Data display channel |
| 18 | +5V | HDMI 5V |
| 19 | Hot Plug Detect | Hot plug Detect |

Note 1. Matched Riverdi 4K HDMI cable accessory: 4K HDMI CABLE

10.4 Touch panel connector -USB-C

| PIN NO. | SYMBOL | DESCRIPTION |
|---------|---------|---|
| A1 | USB_GND | USB_ Ground |
| B12 | USB_GND | USB_ Ground |
| A4 | V_BUS | V_Bus Power; 5V |
| B9 | V_BUS | V_Bus Power; 5V |
| A5 | CC1 | Configuration channel |
| A6 | DPI | USB differential pair, position 1, positive |
| A7 | DN1 | USB differential pair, position 1, negative |



| | | |
|-----|---------|---|
| A8 | SBU1 | Sideband use |
| B5 | CC2 | Configuration channel |
| B6 | DP2 | USB differential pair, position 2, positive |
| B7 | DN2 | USB differential pair, position 2, negative |
| B8 | SBU2 | Configuration channel |
| A9 | V_BUS | V_Bus Power; 5V |
| B4 | V_BUS | V_Bus Power; 5V |
| A12 | USB_GND | USB_Ground |
| B1 | USB_GND | USB_Ground |

Note 1. All the signals in Touch panel connector are in accordance with USB-C standard.

Note 2. Matched Riverdi cable accessory: USB-A 2.0 TO USB-C CABLE

10.5 Light sensor connector – RTI

| PIN NO. | SYMBOL | DESCRIPTION | NOTE |
|---------|------------------|--|--------|
| 1 | GND | Ground | |
| 2 | ADC_IN | ADC Input from Light sensor; Maximum input 3.3V | |
| 3 | NC | No connection | |
| 4 | Light sensor VDD | Light sensor VDD | Note 1 |

Note 1. The output voltage ranges from 3.0 V to 3.6 V. The maximum current is 50mA.

Note 2. Matched Riverdi cable accessory: RVA-0104M-1.25FF

10.6 Backlight PWM &Power -J5

| PIN NO. | SYMBOL | DESCRIPTION | NOTE |
|---------|--------|----------------------------|--------|
| 1 | GND | Ground | |
| 2 | GND | Ground | |
| 3 | EN | Backlight enable, active H | |
| 4 | PWM | PWM input; 3.3V | Note 1 |
| 5 | VDD | Power supply 7.0V - 30.0V | Note 2 |
| 6 | VDD | Power supply 7.0V - 30.0V | |

Note 1. PWM frequency range: 1kHz - 10kHz

Note 2. Pin 5&6 are internally connected with power connector(DC), VDD.

So, the voltage range is the same as power connector(DC)

Note 3. 4 position-DIP onboard switch **SW6** is used to choose the power source to backlight. The settings are:

- INTERNAL BL PWM: Set 1&2 to OFF, and 3&4 to ON,
- EXTERNAL BL PWM: Set 1&2 to ON, and 3&4 to OFF.

Note 4. Matched Riverdi cable accessory: RVA-0106M-1.25FF-1



10.7 UART connector -J2

| PIN NO. | SYMBOL | DESCRIPTION | NOTE |
|---------|----------|---------------|--------|
| 1 | GND | Ground | |
| 2 | RXD | Receive Data | |
| 3 | TXD | Transmit Data | |
| 4 | VDD_UART | UART VDD | Note 2 |

Note 1. UART functionality is under development process.

Note 2. The output voltage ranges from 3.0 V to 3.6 V. The maximum current is 50mA.

Note 3. Matched Riverdi cable accessory: RVA-0104M-1.25FF

10.8 External Keyboard connector - J1

| PIN NO. | SYMBOL | DESCRIPTION |
|---------|--------------|--------------------------------|
| 1 | Down | Page down |
| 2 | Up | Page up |
| 3 | Exit | Exit |
| 4 | Menu | Menu |
| 5 | PWR | Power on/off |
| 6 | LED_EN | LED Enable; Output signal 3.3V |
| 7 | GND | Ground |
| 8 | Keyboard VDD | Keyboard VDD; Output 3.3V |

Note 1. Matched Riverdi cable accessory: RVA-0108M-1.25FF

11. DISPLAY SPECIFICATION

The TFT of the module applies Riverdi high brightness, IPS, 7.0" RGB: RVT70HSTFWCA0

The supported resolution of the display in this module is 1024*600.

For detailed information, please refer to datasheet of display.

12. CAPACITIVE TOUCH SCREEN PANLE SPECIFICATIONS

12.1 Mechanical characteristics

| DESCRIPTION | SPECIFICATION | REMARK |
|--------------------------|----------------------|--------|
| Touch Panel Size | 7.0 inch | aTouch |
| Outline Dimension of CTP | 164.70 mm x 99.80 mm | |
| Product Thickness | 2.45 mm | |
| Glass Thickness | 1.1 mm | |
| CTP View Area | 155.01 mm x 86.72 mm | |
| Sensor Active Area | 156.08 mm x 88.42 mm | |
| Structure type | Glass + Glass | |
| Surface Hardness | 7H | |

12.2 Electrical characteristics

| PARAMETER | | SPECIFICATION | REMARK |
|-------------------|-------------|---------------|--------|
| Power | Active Mode | 90 mA | aTouch |
| Consumption (IDD) | Sleep Mode | 10 mA | |
| Linearity | | +/-1.5mm | |
| Controller | | ILI2132A | |
| Resolution | | 1024 x 600 | |

13.INSPECTION

Standard acceptance/rejection criteria for TFT module

13.1 Inspection condition

Ambient conditions:

- Temperature: $25 \pm 2^{\circ}\text{C}$
- Humidity: $(60 \pm 10) \%RH$
- Illumination: Single fluorescent lamp non-directive (300 to 700 lux)

Viewing distance: $35 \pm 5\text{cm}$ between inspector bare eye and LCD.

Viewing Angle: U/D: $45^{\circ}/45^{\circ}$, L/R: $45^{\circ}/45^{\circ}$

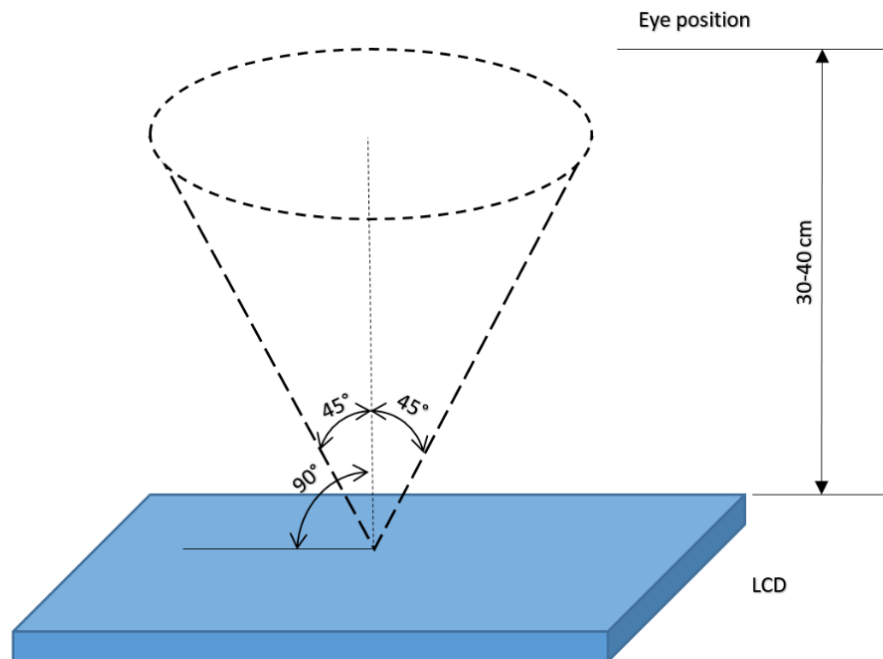



13.2 Inspection standard

| ITEM | | CRITERION | | |
|--|--|--|---------------------|---------------|
| Black spots, white spots, light leakage, Foreign Particle (round Type) | <p>$D=(x+y)/2$ Spots density: 10 mm</p> | Size = 7" | | |
| | | Average Diameter | Qualified Qty | |
| | | $D \leq 0.2 \text{ mm}$ | Ignored | |
| | | $0.2 \text{ mm} < D \leq 0.3 \text{ mm}$ | N≤3 | |
| | | $0.5\text{mm} < D$ | Not allowed | |
| LCD black spots, white spots, light leakage (line Type) | | Size = 7" | | |
| | | Length | Width | Qualified Qty |
| | | - | $W \leq 0.05$ | Ignored |
| | | $L \leq 5.0$ | $0.05 < W \leq 0.1$ | 3 |
| | | $5.0 < L$ | $0.1 < W$ | Not allowed |
| Bright/Dark Dots | Size = 7" | | | |
| | Item | Qualified Qty | | |
| | Bright dots | N≤2 | | |
| | Dark dots | N≤3 | | |
| Total bright and dark dots | | N≤4 | | |
| Clear spots | Size ≥ 5" | | | |
| | Average Diameter | Qualified Qty | | |
| | $D < 0.2 \text{ mm}$ | Ignored | | |
| | $0.2 \text{ mm} < D < 0.3 \text{ mm}$ | 4 | | |
| | $0.3 \text{ mm} < D < 0.5 \text{ mm}$ | 2 | | |
| $0.5 \text{ mm} < D$ | | 0 | | |
| Polarizer bubbles | Size = 7" | | | |
| | Average Diameter | Qualified Qty | | |
| | $D \leq 0.2 \text{ mm}$ | Ignored | | |
| | $0.2 \text{ mm} < D \leq 0.5 \text{ mm}$ | 2 | | |
| $0.5 \text{ mm} < D$ | | 1 | | |
| Touch panel spot | Size ≥ 5" | | | |
| | Average Diameter | Qualified Qty | | |
| | $D < 0.25 \text{ mm}$ | Ignored | | |
| | $0.25 \text{ mm} < D < 0.5 \text{ mm}$ | 4 | | |
| $0.5 \text{ mm} < D$ | | 0 | | |
| Size ≥ 5" | | | | |



| | | | |
|--------------------------------------|-----------|-------------------|---------------|
| Touch panel White line Scratch | Length | Width | Qualified Qty |
| | - | $W < 0.03$ | Ignored |
| | $L < 5.0$ | $0.03 < W < 0.05$ | 2 |
| | - | $0.05 < W$ | 0 |

14. RELIABILITY TEST

| NO. | TEST ITEM | TEST CONDITION |
|-----|-------------------------------------|--|
| 1 | High Temperature Storage | 80°C/120 hours |
| 2 | Low Temperature Storage | -30°C/120 hours |
| 3 | High Temperature Operating | 70 °C /120 hours |
| 4 | Low Temperature Operating | -20°C/120 hours |
| 5 | High Temperature and High Humidity | Humidity 40°C, 90%RH, 120Hrs |
| 6 | Thermal Cycling Test (No operation) | -20°C for 30min, 70°C for 30 min. 100 cycles. Then test at room temperature after 1 hour |
| 7 | Vibration Test | Frequency: 10 ÷ 55 Hz. Stroke: 1.5 mm. Sweep: 10Hz ÷ 55Hz ÷ 10 Hz. 2 hours for each direction of X, Y, Z (Total 6 hours) |

Note 1. Sample quantity for each test item is 5 ÷ 10 pcs.

Note 2. Before cosmetic and function test, the product must have enough recovery time, at least 2 hours at room temperature.



15. LEGAL INFORMATION

CE marking is usually obligatory only for a complete end product. Riverdi display modules are semi-finished goods which are used as inputs to become part of the finished products.

Therefore, Riverdi display modules are not CE marked.

Riverdi grants the guarantee for the proper operation of the goods for a period of 12 months from the date of possession of the goods. If in a consequence of this guaranteed execution the customer has received the defects-free item as replacement for the defective item, the effectiveness period of this guarantee shall start anew from the moment the customer receives the defects-free item.

Information about device is the property of Riverdi and may be the subject of patents pending or granted. It is not allowed to copy or disclosed this document without prior written permission.

Riverdi endeavors to ensure that all contained information in this document is correct but does not accept liability for any error or omission. Riverdi products are in developing process and published information may be not up to date. Riverdi reserves the right to update and makes changes to Specifications or written material without prior notice at any time. It is important to check the current position with Riverdi.

Images and graphics used in this document are only for illustrative the purpose. All images and graphics are possible to be displayed on the range products of Riverdi, however the quality may vary. Riverdi is no liable to the buyer or to any third party for any indirect, incidental, special, consequential, punitive, or exemplary damages (including without limitation lost profits, lost savings, or loss of business opportunity) relating to any product, service provided or to be provided by Riverdi, or the use or inability to use the same, even if Riverdi has been advised of the possibility of such damages.

Riverdi products are not fault tolerant nor designed, manufactured or intended for use or resale as on line control equipment in hazardous environments requiring fail-safe performance, such as in the operation of nuclear facilities, aircraft navigation or communication systems, air traffic control, direct life support machines or weapons systems in which the failure of the product could lead directly to death, personal injury or severe physical or environmental damage ('High-Risk Activities'). Riverdi and its suppliers specifically disclaim any expressed or implied warranty of fitness for High-Risk Activities. Using Riverdi products and devices in 'High-Risk Activities' and in any other application is entirely at the buyer's risk, and the buyer agrees to defend, indemnify, and hold harmless Riverdi from all damages, claims or expenses resulting from such use. No licenses are conveyed, implicitly or otherwise, under any Riverdi intellectual property rights.



Hi, I am here to help you!
If you have any additional questions, please contact our support via email:
contact@riverdi.com

