



## RVT70HSSNWC00

## STM32 EMBEDDED 7.0" DISPLAY DATASHEET

Rev.1.1  
2022-12-15

ITEM	CONTENTS	UNIT
LCD Type	TFT/Transmissive/Normally Black/IPS	/
Size	7.0	Inch
Viewing Direction	Free	/
Outside Dimensions (W x H x D)	179.96 x 119.00 x 21.07	mm
Active Area (W x H)	154.21 x 85.92	mm
Pixel Pitch (W x H)	0.1506 x 0.1432	mm
Resolution	1024 x 600	/
Brightness	800	cd/m <sup>2</sup>
Color Depth	16.7 M	/
Pixel Arrangement	RGB Vertical Stripe	/
Driver MCU of Board	STM32H757XIH6	/
External SDRAM	64Mbit (32-bit access)	/
External Flash Memory	512Mbit	/
Supply Voltage for Module	6.0 - 48.0	V
With/Without Touch	With Projected Capacitive Touch Panel	/
CTP Driver	ILI2132A	/
Weight	295	g

**Note 1.** RoHS3 compliant

**Note 2.** LCM weight tolerance:  $\pm 5\%$



## 1. REVISION RECORD

REV NO.	REV DATE	CONTENTS	REMARKS
0.1	2022-03-28	Preliminary version	
1.0	2022-07-07	Initial Release <ul style="list-style-type: none"><li>• Update the measurement data of electrical parameters</li><li>• Update drawing with adding heatsink</li><li>• Adding photos of PCB board</li></ul>	
1.1	2022-12-15	New PCB version: 70STM32H7_Rev1.1 <ul style="list-style-type: none"><li>• MCU is switched from STM32H747XIH6 to STM32H757XIH6</li><li>• The maximum supply voltage is increased to 48.0V</li><li>• Coin cell holder for CR1220 is added</li><li>• New method to set BLVDD SELECTOR</li></ul>	



## 2. CONTENTS

1.	REVISION RECORD.....	2
2.	CONTENTS.....	3
3.	MODULE CLASSIFICATION INFORMATION.....	4
4.	uxTouch ASSEMBLY GUIDE.....	5
5.	MODULE DRAWING.....	6
6.	ABSOLUTE MAXIMUM RATINGS.....	7
7.	ELECTRICAL CHARACTERISTICS.....	7
8.	BACKLIGHT ELECTRICAL CHARACTERISTICS.....	7
9.	ELECTRO-OPTICAL CHARACTERISTICS.....	8
10.	BOARD INTERFACES AND CONNECTORS.....	10
10.1	Power input connector.....	10
10.2	USB interface.....	11
10.3	RS485 interface.....	11
10.4	RS232 interface.....	11
10.5	2 x CAN FD interfaces.....	12
10.6	Haptic feedback connector.....	12
10.7	SWD (Serial Wire Debug) connector.....	12
10.8	RiBUS.....	13
10.9	Expansion connector.....	15
10.10	Micro SD card slot.....	16
10.11	2 x 20-pin, 1.27 mm pin sockets for POE Add-on Board.....	16
10.12	Battery coin cell holder.....	16
11.	USER INTERFACES.....	17
11.1	3 x push buttons.....	17
11.2	3 x LEDs.....	17
12.	DISPLAY SPECIFICATION.....	18
12.1	Full TFT specification.....	18
13.	CAPACITIVE TOUCH SCREEN PANEL SPECIFICATIONS.....	18
13.1	Mechanical characteristics.....	18
13.2	Electrical characteristics.....	18
14.	INSPECTION.....	19
14.1	Inspection condition.....	19
14.2	Inspection standard.....	20
15.	RELIABILITY TEST.....	21
16.	LEGAL INFORMATION.....	22



### 3. MODULE CLASSIFICATION INFORMATION

RV	T	70	H	S	S	N	W	C	00
1.	2.	3.	4.	5.	6.	7.	8.	9.	10.

NO.	PARAMETER	SYMBOL
1.	BRAND	RV – Riverdi
2.	PRODUCT TYPE	T – TFT Standard
3.	DISPLAY SIZE	70 – 7.0"
4.	MODEL SERIAL NO.	H – High Brightness, IPS TFT
5.	RESOLUTION	S – 1024 x 600 px
6.	LCD+CONTROL BOARD	S – STM32 Embedded Display MCU STM32H757XIH6
7.	FRAME	N – Without Mounting Metal Frame
8.	BACKLIGHT TYPE	W – LED White
9.	TOUCH PANEL	C – With Capacitive Touch Panel
10.	VERSION	00 – (00-99)

#### 4. uxTouch ASSEMBLY GUIDE

uxTouch are LCD TFT displays with specially designed projected capacitive touch panels. uxTouch display can be mounted without any holes in the housing. Our standard uxTouch displays include double-sided adhesive tape (DST) to stick TFT easily to the housing. Basic series include 4.3", 5.0", 7.0" and 10.1" display sizes.

uxTouch models with double-side adhesive tape can be mounted by connecting the glass to the housing. Riverdi recommends using support brackets assembled to display's back. An additional support will stiffen the whole structure and minimize the influence of external factors such as vibration. Figure 1 below shows examples of using support elements.

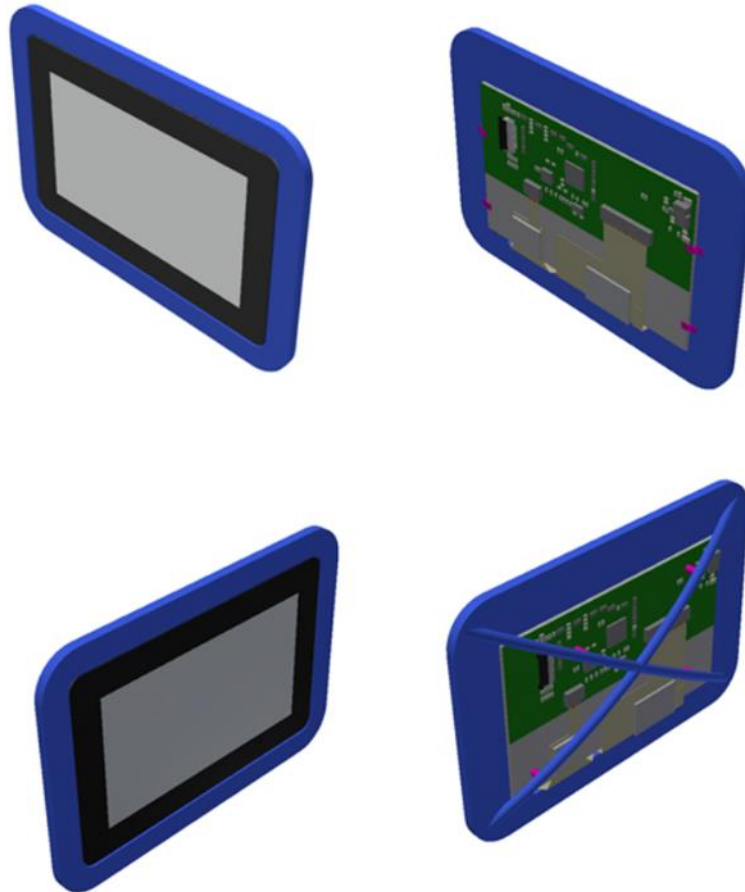
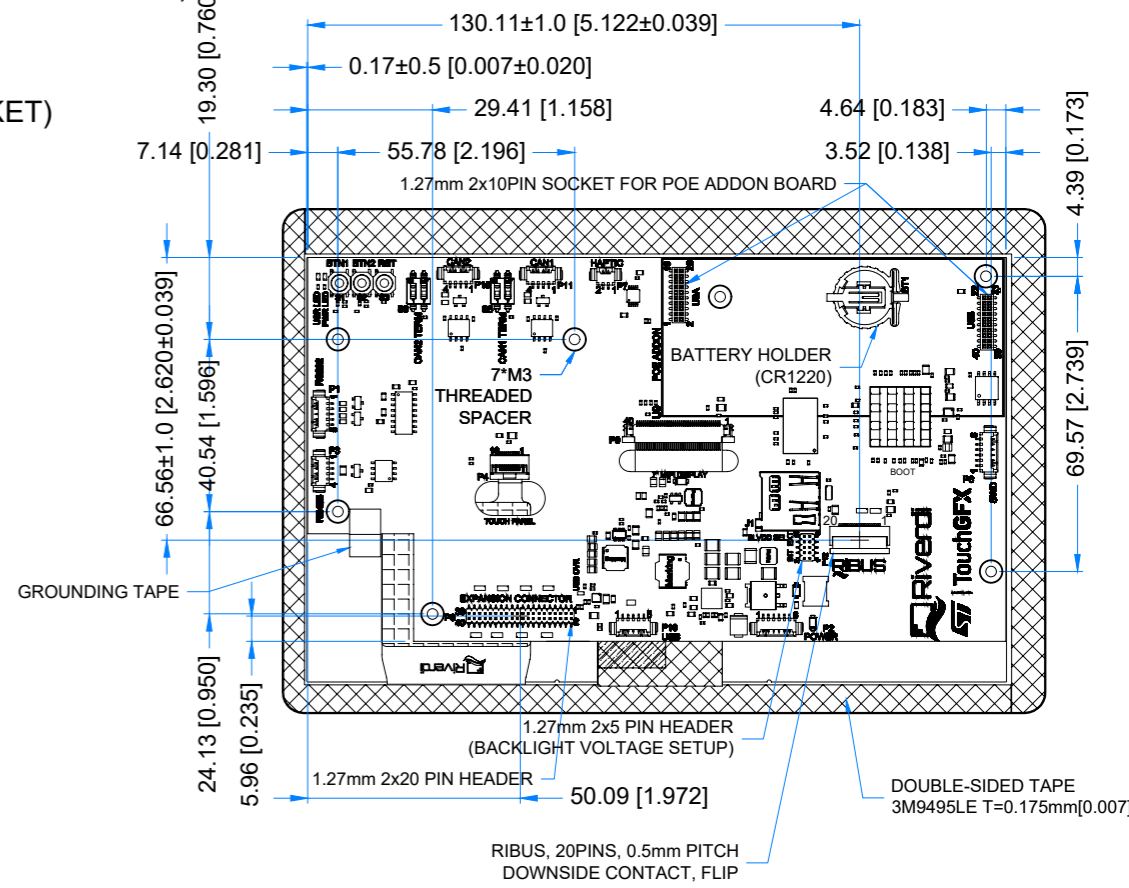
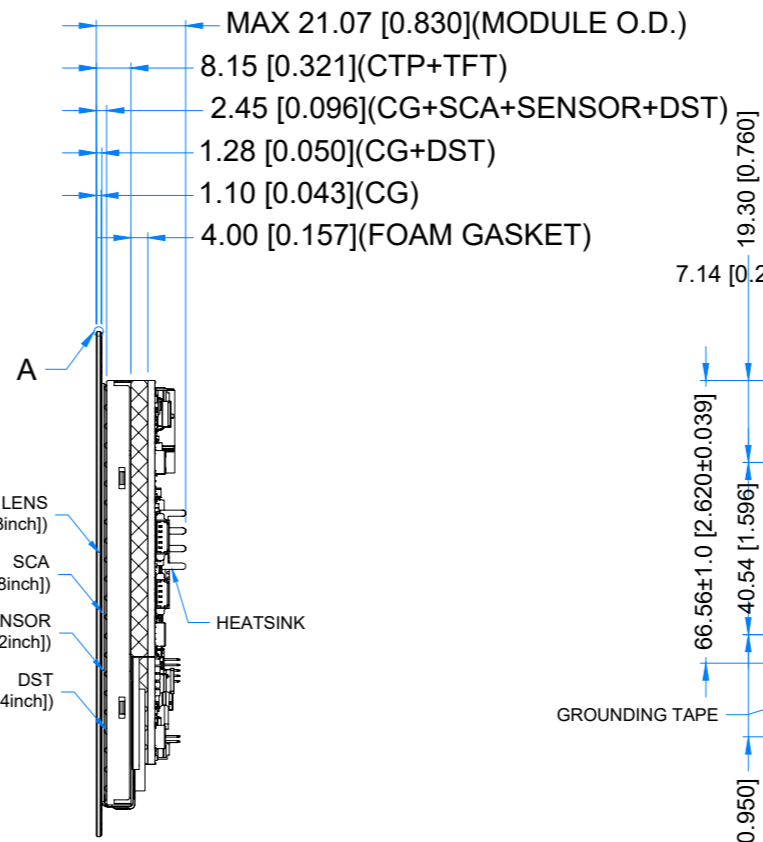
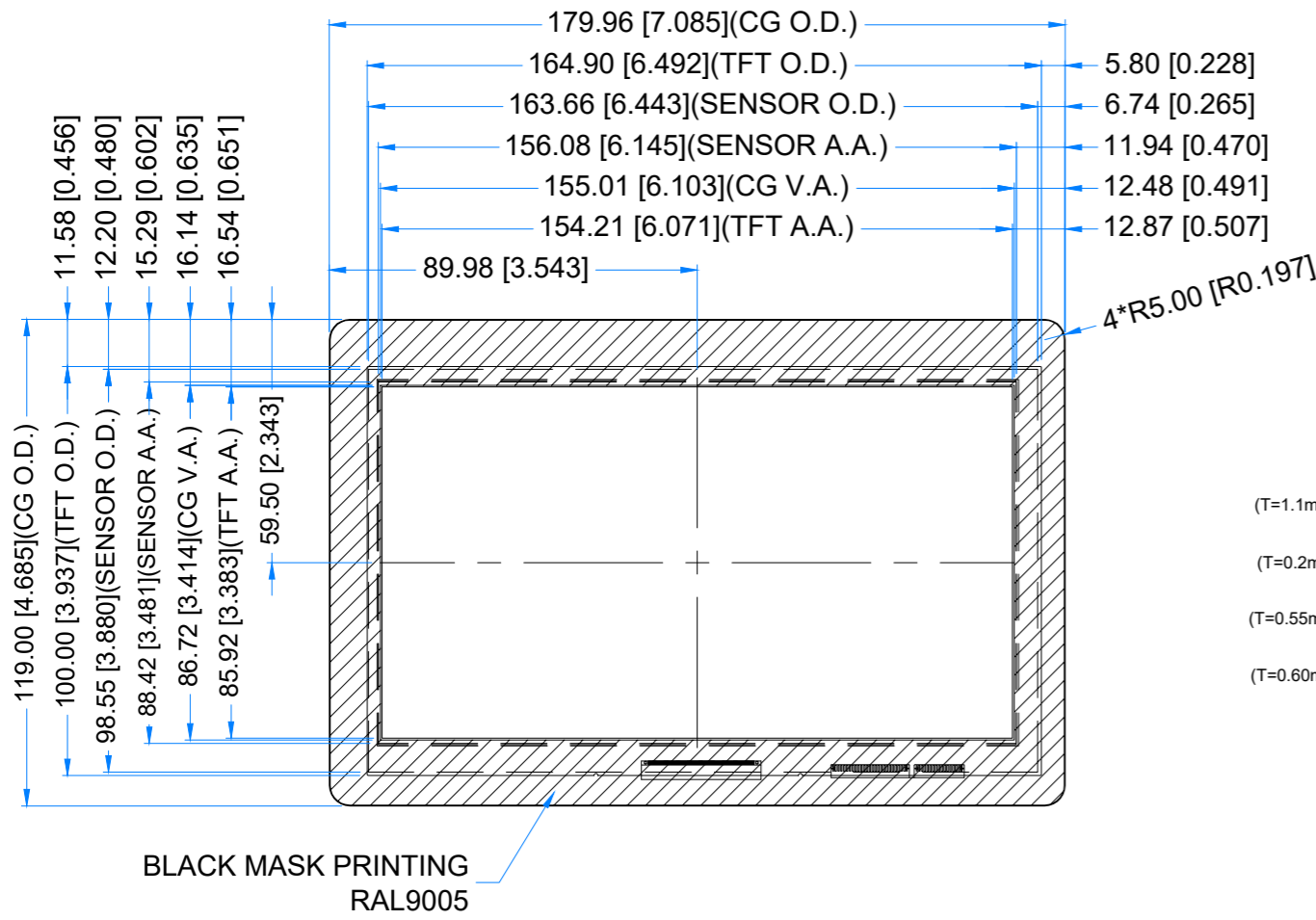
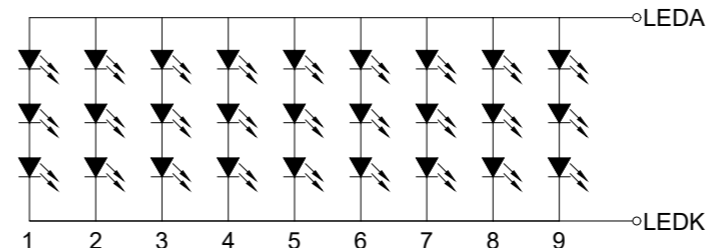
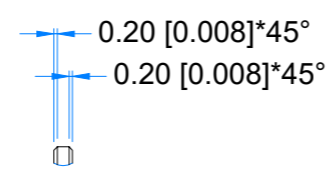

Figure 1. Example of using support brackets

Revision:	Changes:	Date:
1.0	Initial Case	2022.04.08
1.1	Added Heatsink And Dimensions Overhaul	2022.07.12
1.2	PCB Update - 70STM32H7_Rev1.2	2022.10.28



DETAIL A  
SCALE 4:1



LED Diagram Circuit

1.27MM PIN HEADER AND SOCKET		
NO.	TYPE	MATE WITH
P8	CH51402M100-0P	CBC1402D100 OR CBC1402M100-2P
U9a & U9b	PBHTD20SPP	CH51202V100 OR CH51202M100-0P
P12	62131021021	62200213421 (JUMPER)

1.25 MM MOLEX CONNECTORS		
NO.	TYPE	MATE WITH
P1 (RS232)	53261-0571	51021-0500
P2 (POWER)	53261-0671	51021-0600
P3 (RS485)	53261-0471	51021-0400
P6 (SWD)	53261-0671	51021-0600
P7 (HAPTIC)	53261-0271	51021-0200
P10 (USB)	53261-0571	51021-0500
P11 (CAN1)	53261-0471	51021-0400
P15 (CAN2)	53261-0471	51021-0400

**TFT NOTES:**  
1. DISPLAY TYPE: TRANSMISSIVE, NORMALLY BLACK, IPS  
2. RESOLUTION: 1024x600  
3. VIEWING ANGLE: FREE  
4. SURFACE LUMINANCE: 800 cd/m<sup>2</sup>  
5. MCU ON THE BOARD: STM32H757XIH6  
6. EXTERNAL FLASH MEMORY SIZE: 512Mbit  
7. EXTERNAL SDRAM SIZE: 64Mbit (32-bit access)  
8. SUPPLY VOLTAGE FOR MODULE: 6.0V - 48.0V

**TP NOTES:**  
1. TP STRUCTURE: G+G  
2. CG THICKNESS: 1.10mm[0.043inch]  
3. SURFACE HARDNESS: 7H  
4. DRIVER IC: ILI2132A  
5. INTERFACE: CONNECTED TO MCU VIA I2C

**GENERAL NOTES:**  
1. AIR BONDING  
2. OPERATING TEMPERATURE: -20°C ~ 70°C  
3. STORAGE TEMPERATURE: -30°C ~ 80°C  
4. WITHOUT INDIVIDUAL TOLERANCE: ±0.3mm[0.012inch]  
5. TOLERANCE OF PCB PLACEMENT: ±0.5mm[0.020inch]  
6. RoHS3 COMPLIANT

PN: RVT70HSSNWC00
SN:
DRAWN: M.Natywa
CHECKED: Carol Gao
APPR:

**Riverdi**

2022.10.28	1:1.78	
2022.11.07	[mm]	
ISO A3	P. 1 of 1	



## 6. ABSOLUTE MAXIMUM RATINGS

PARAMETER	SYMBOL	MIN	MAX	UNIT	NOTE
Supply Voltage for Module	VDD_IN	0.0	60.0	V	Note 1
Digital I/O signals Voltage	-	-0.5	3.3		Note 1,2
Operating Temperature	T <sub>OP</sub>	-20	70	°C	
Storage Temperature	T <sub>ST</sub>	-30	80	°C	
Storage Humidity (@ 25 ± 5°C)	H <sub>ST</sub>	10	-	% RH	
Operating Ambient Humidity (@ 25 ± 5°C)	H <sub>OP</sub>	10	-	% RH	

**Note 1.** Exceeding maximum values may cause improper operation or permanent damage to the unit.

**Note 2.** Most of the GPIOs have the 5.0 V tolerant input voltage, please refer to the datasheet of STM32H757XIH6 for more details.

## 7. ELECTRICAL CHARACTERISTICS

PARAMETER	SYMBOL	MIN	TYP	MAX	UNIT
Supply Voltage for Module	VDD_IN	6.0	12.0	48.0	V
Power Enable Voltage	VEN	0	-	VDD_IN	V
Input Voltage "H" Level	V <sub>IH</sub>	2.0	-	3.3	V
Input Voltage "L" Level	V <sub>IL</sub>	0	-	0.8	V

PARAMETER	CONDITION	SYMBOL	MIN	TYP	MAX	UNIT
Current Drawn from VDD_IN @6.0V	POWER 'ENABLE' = '0'	I <sub>VDD_IN</sub>	-	60	-	uA
Current Drawn from VDD_IN @12.0V			-	150	-	uA
Current Drawn from VDD_IN @24.0V			-	390	-	uA
Current Drawn from VDD_IN @36.0V			-	630	-	uA
Current Drawn from VDD_IN @48.0V			-	880	-	uA
Current Drawn from VDD_IN @6.0V	POWER 'ENABLE' = '1'	I <sub>VDD_IN</sub>	-	850	-	mA
Current Drawn from VDD_IN @12.0V			-	420	-	mA
Current Drawn from VDD_IN @24.0V			-	220	-	mA
Current Drawn from VDD_IN @36.0V			-	160	-	mA
Current Drawn from VDD_IN @48.0V			-	128	-	mA

**Note.** POWER 'ENABLE' refers to pin 4, 'ENABLE' of the power input connector(P2).

POWER 'ENABLE' = '1' is when EN pin is floating or shorted to VDD\_IN.

POWER 'ENABLE' = '0' is when EN pin is shorted to GND.

By default, POWER 'ENABLE' is set to "1".

## 8. BACKLIGHT ELECTRICAL CHARACTERISTICS

PARAMETER	SYMBOL	MIN	TYP	MAX	UNIT	NOTE
Lifetime	-	-	50,000	-	hours	Note 1

**Note 1.** Operating life means the period in which the LED brightness goes down to 50% of the initial brightness. Typical operating lifetime is the estimated parameter.



## 9. ELECTRO-OPTICAL CHARACTERISTICS

ITEM	SYMBOL	CONDITION	MIN	TYP	MAX	UNIT	RMK	NOTE
Response Time	Tr+Tf	$\theta=0^\circ$ $\varnothing=0^\circ$ Ta=25 °C	-	35	-	ms	FIG 2.	4
Contrast Ratio	Cr		800	1000	-	---	FIG 3.	1
Luminance Uniformity	$\delta$ WHITE		-	75	-	%		3
Surface Luminance	Lv		-	800	-	cd/m <sup>2</sup>		2
Viewing Angle Range	$\theta$	$\varnothing = 90^\circ$	75	85	-	deg	FIG 4.	6
		$\varnothing = 270^\circ$	75	85	-	deg		
		$\varnothing = 0^\circ$	75	85	-	deg		
		$\varnothing = 180^\circ$	75	85	-	deg		
CIE (x, y) Chromaticity	Rx	$\theta=0^\circ$ $\varnothing=0^\circ$ Ta=25 °C	0.578	0.618	0.658	-	FIG 3.	5
	Ry		0.489	0.329	0.369	-		
	Gx		0.376	0.416	0.456	-		
	Gy		0.493	0.533	0.573	-		
	Bx		0.071	0.111	0.151	-		
	By		0.108	0.148	0.188	-		
	Wx		0.270	0.310	0.350	-		
	Wy		0.290	0.330	0.370	-		

**Note 1.** Contrast Ratio (CR) is defined mathematically as below, for more information see Figure 3.

$$\text{Contrast Ratio} = \frac{\text{Average Surface Luminance with all white pixels (P1, P2, P3, P4, P5)}}{\text{Average Surface Luminance with all black pixels (P1, P2, P3, P4, P5)}}$$

**Note 2.** Surface luminance is the LCD surface from the surface with all pixels displaying white. For more information see Figure 3.

$$L_v = \text{Average Surface Luminance with all white pixels (P1, P2, P3, P4, P5)}$$

**Note 3.** The uniformity in surface luminance  $\delta$  WHITE is determined by measuring luminance at each test position 1 through 5, and then dividing the minimum luminance of 5 points luminance by maximum luminance of 5 points luminance. For more information see Figure 3.

$$\delta \text{ WHITE} = \frac{\text{Minimum Surface Luminance with all white pixels (P1, P2, P3, P4, P5)}}{\text{Maximum Surface Luminance with all white pixels (P1, P2, P3, P4, P5)}}$$

**Note 4.** Response time is the time required for the display to transition from white to black (Rise Time, Tr) and from black to white (Decay Time, Tf). For additional information see Figure 2. The test equipment is BM-7A.

**Note 5.** CIE (x, y) chromaticity, the x, y value is determined by measuring luminance at each test position 1 through 5, and then calculating the average value.

**Note 6.** For TFT module the contrast ratio is greater than 10. The angles are determined for the horizontal or x axis and the vertical or y axis with respect to the z axis which is normal to LCD surface. For more information see Figure 4.



**Note 7.** Viewing angle is measured at the center point of the LCD by CONOSCOPE (ergo-80). For response time testing, the testing data is based on BM-7A. Instruments for Contrast Ratio, Surface Luminance, Luminance Uniformity, Chromaticity the test data is based on SR-3A.

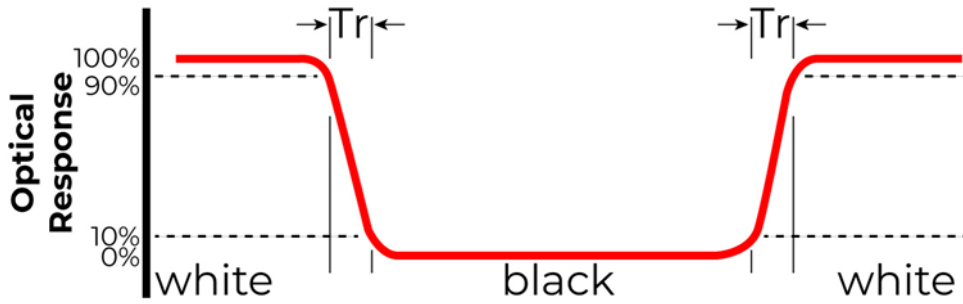

Figure 2. The definition of response time

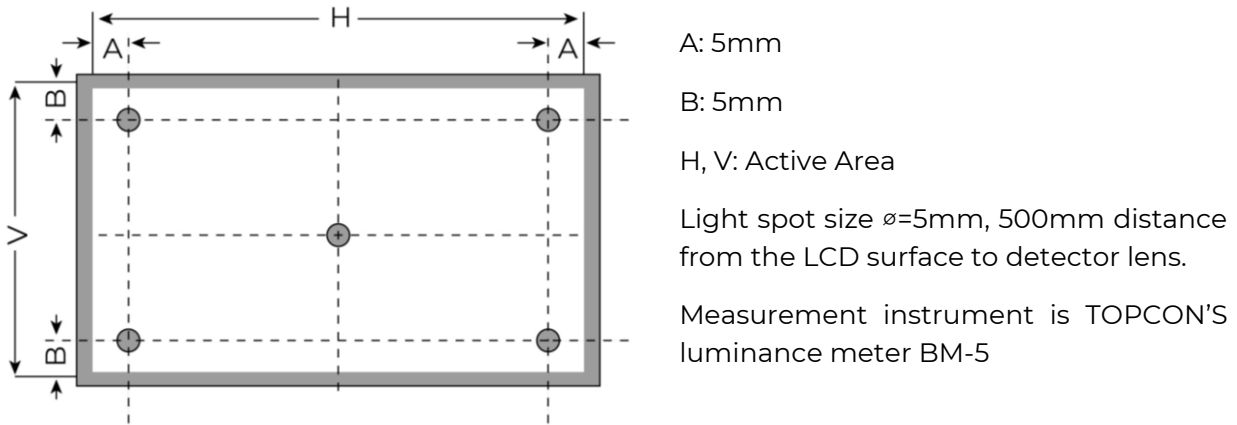

Figure 3. Measuring method for Contrast ratio, surface luminance, Luminance uniformity, CIE (x, y) chromaticity

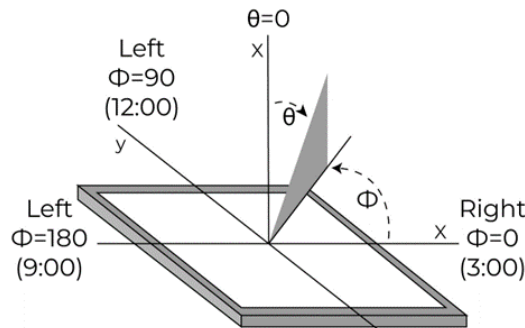
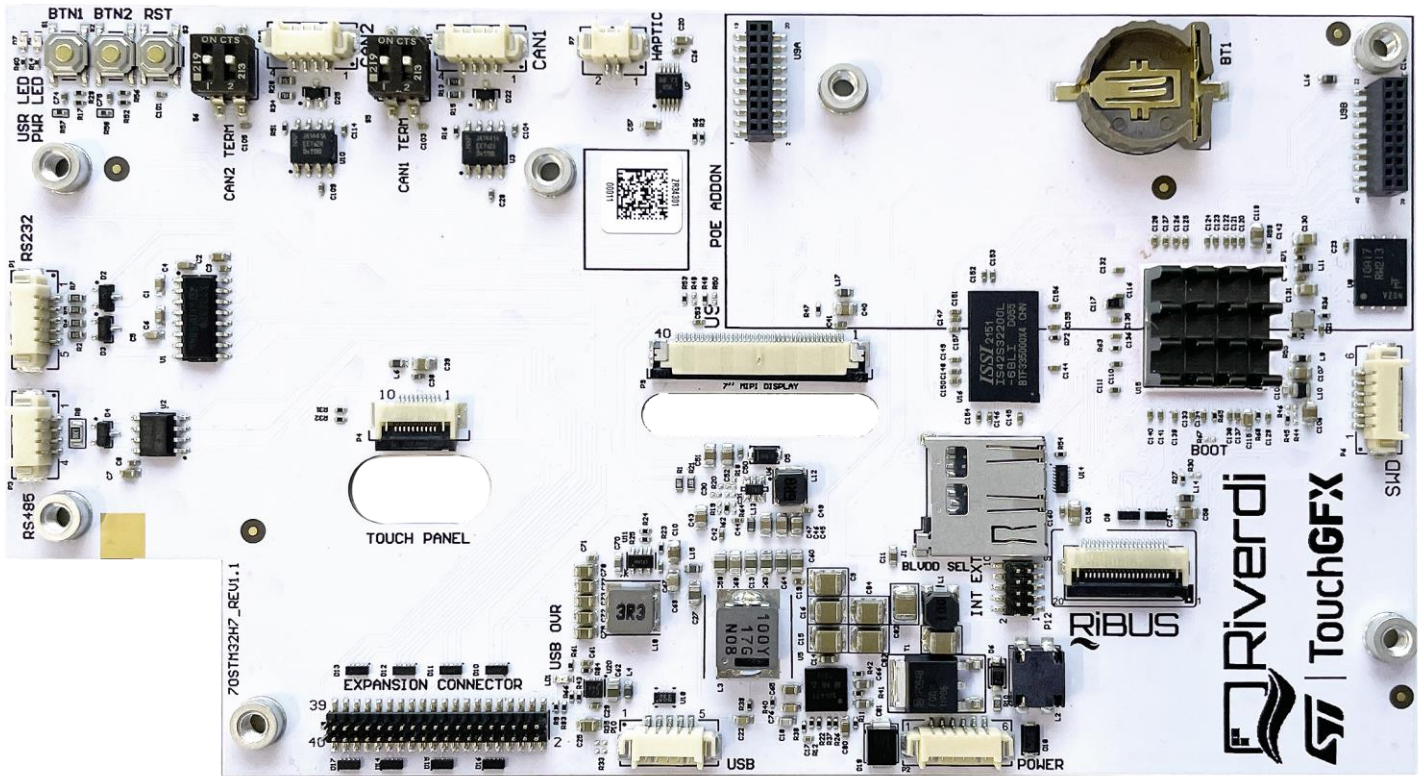

Figure 4. The definition of viewing angle

## 10. BOARD INTERFACES AND CONNECTORS



### 10.1 Power input connector

The 1.25mm, 6-pin Molex connector labeled as “POWER’ (P2) is power input connector.

There is an internal reverse polarity protection which ensures that the device is not damaged if the power supply polarity is reversed.

NO.	PIN	DESCRIPTION	NOTE
1	VDD_IN	Power supply input; 6.0-48.0V	Note 1
2	VDD_IN	Power supply input; 6.0-48.0V	
3	VDD_IN	Power supply input; 6.0-48.0V	
4	ENABLE	Enable/Disable power supply	Note 2
5	GND	Ground	
6	GND	Ground	

**Note 1.** STM32 Embedded Display allows to directly connect one additional display to the system. There is RiBUS connector on the board where you can connect any of intelligent display from Riverdi based on EVE4 (BT817Q). However, please note that it may change power supply requirement as below:

The power supply voltage ranges between 6.0 V- 48.0V if any of Riverdi EVE4 3.5”,4.3”,5.0” and 7.0” series display is connected through RiBUS. At the same time, jumper P12 shall be configured according to subchapter 10.8, Table 1.

The power supply voltage must range between 7.0V- 14.0 V (TYP. 9.0 V), if Riverdi EVE4 10.1” series display is connected through RiBUS. At the same time, jumper P12 shall be configured according to subchapter 10.8, Table 2.



**Note 2.** Pin “ENABLE” is internally pulled up to VDD\_IN. To enable the device, please keep EN pin floating or short it to pin” VDD\_IN”. To disable the device, short EN pin to GND.

**Note 3.** Matched Riverdi power supply cable: RVA-0106M-1.25FF-1.

## 10.2 USB interface

The 1.25mm, 5-pin Molex connector labeled as “USB’ (P10) is USB interface.

NO.	PIN	DESCRIPTION	NOTE
1	VCC_USB	Power supply	Note 1
2	D-	USB data-	
3	D+	USB data+	
4	ID	USB OTG ID; Host /Device detect	Note 2
5	GND	Ground	

**Note 1.** The maximum current drawn from VCC\_USB is 500mA.

**Note 2.** Configuration of the USB Host/Device mode:

**Host Mode:** Pin 4 (ID) should be connected to GND.

In this mode, it can provide +5V output voltage to the connected USB device and Max output current 500 mA.

**Device Mode:** Pin 4 (ID) should be not connected (floating).

**Note 3.** Matched Riverdi cable accessory: RVA-0105M-1.25FF

## 10.3 RS485 interface

The 1.25mm, 4-pin Molex connector labeled as “RS485’ (P3) is RS485 interface.

NO.	PIN	DESCRIPTION	NOTE
1	VDD_IN	Power supply input; 6.0-48.0V	
2	A	Non-inverting receiver input and non-inverting driver output	
3	B	Inverting receiver input and inverting driver output	
4	GND	Ground	

**Note.** Matched Riverdi cable accessory: RVA-0104M-1.25FF

## 10.4 RS232 interface

The 1.25mm, 5-pin Molex connector labeled as “RS232’ (P1) is RS232 interface.

NO.	PIN	DESCRIPTION	NOTE
1	RTS	Request to send	
2	CTS	Clear to send	
3	TXD	Transmit Data	
4	RXD	Receive Data	
5	GND	Ground	

**Note.** Matched Riverdi cable accessory: RVA-0105M-1.25FF



## 10.5 2 x CAN FD interfaces

The main board supports 2 channels of the CANFD (Control Area Network Flexible Data-Rate) communication bus, based on the high-speed (2.5-8.0Mbps) CAN transceiver.

2 pcs of 1.25mm, 4-pin Molex connectors labeled as "CAN1" (P11) and "CAN2" (P15) are respectively interfaces of CAN FD1 and CAN FD2.

NO.	PIN	DESCRIPTION	NOTE
1	GND	Ground	
2	CAN_L	CAN Low-Level Voltage	
3	CAN_H	CAN High-Level Voltage	
4	VDD_IN	Power supply input; 6.0 – 48.0 V	

**Note.** Matched Riverdi cable accessory: RVA-0104M-1.25FF

## 10.6 Haptic feedback connector

The 1.25mm, 2-pin Molex connector labeled as "HAPTIC" (P7) is haptic feedback connector.

Haptic feedback P7 is used to connect with the haptic motor directly.

NO.	PIN	DESCRIPTION	NOTE
1	OUT-	Negative haptic driver differential output	Note 1
2	OUT+	Positive haptic driver differential output	

**Note 1.** The haptic driver DRV2605L is controlled directly by I2C protocol.

**Note 2.** Matched Riverdi cable accessory: RVA-0102M-1.25FF

## 10.7 SWD (Serial Wire Debug) connector

The 1.25mm, 6-pin Molex connector labeled as 'SWD' (P6) is SWD interface, which is used for programing the MCU on board.

NO.	PIN	DESCRIPTION	NOTE
1	VCC_+3.3V	Power input	
2	SW_CLK	Serial wire clock	
3	GND	Ground	
4	SW_DIO	Serial wire debug data input/output	
5	RST	Reset; Active low	
6	SWO	Serial wire trace output	Note 2

**Note 1.** Riverdi ST-LINK/V2 SWD programing cable: RVA-SWD-06M-C100

**Note 2.** SWO is muxed with SPI\_SCLK of RiBUS. By default, SWO is disconnected.

To enable it, please remove R27 and short R30.



## 10.8 RiBUS

Any size of the Riverdi EVE4 series display can be connected through RiBUS to act as a slave module to the mainboard.

NO.	PIN	DESCRIPTION	NOTE
1	VCC_+3.3V	Supply voltage for module; TYP3.3V	
2	GND	Ground	
3	SPI_SCLK	SPI SCK signal	
4	MISO/ IO.1	SPI MISO signal / SPI Quad mode: SPI data line 1	
5	MOSI/ IO.0	SPI MOSI signal / SPI Quad mode: SPI data line 0	
6	CS	SPI chips select signal	
7	INT	Interrupt signal from device to the system, Active Low	
8	RST/PD	Reset / Power down signal, Active Low,	
9	GPIO.0	GPIO.0	
10	DISP_AUDIO	Display audio in/out	
11	GPIO.1/IO.2	SPI Single/Dual mode: General purpose IO0. QSPI mode: SPI data line 2	
12	GPIO.2/IO.3	SPI Single/Dual mode: General purpose IO1. QSPI mode: SPI data line 3	
13	NC	Not connected	
14	NC	Not connected	
15	NC	Not connected	
16	NC	Not connected	
17	BLVDD	Supply voltage for backlight	Note 2
18	BLVDD	Supply voltage for backlight	
19	BLGND	Backlight Ground, internally connected to GND	
20	BLGND	Backlight Ground, internally connected to GND	

**Note 1.** Matched Riverdi FFC accessory: FFC0520150

**Note 2.** For Riverdi EVE4 series display ranging from sizes of 3.5" to 7.0", the backlight voltage (BLVDD) shall be 5.0V.

For Riverdi EVE4 10.1" series displays, the backlight voltage (BLVDD) must range between 7.0 - 14.0V (TYP. 9V).

Backlight jumper selectors, P12, labeled as "BLVDD SEL EXT INT" is used to configure the backlight voltage range.

Table 1 and 2 show how to configure internal backlight voltage and external backlight voltage.

**Warning!** Jumper configuration shall be done when module is not powered.

**DO NOT change ANY jumpers while the module has power.** Improper operation might cause permanent damage to the unit.

Please pay special attention to not misplace the jumpers. **Incorrect jumpers setting may lead to damage to the module as well.**

The P12 jumper setting is shown below.

Table 1. Internal backlight selector setting: 5.0V (default) backlight voltage

SETTING	PIN 1 & 2	PIN 3 & 4	PIN5 – PIN10
5.0 V	Short	Short	Open

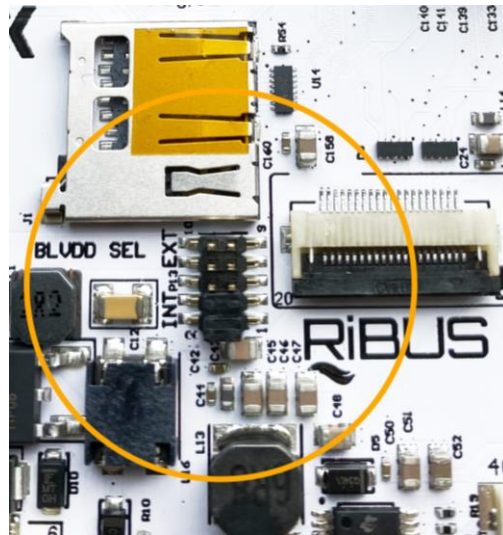

Figure 5. Internal backlight jumper setting

Table 2. External backlight selector setting: 7.0V-14.0V backlight voltage

SETTING	PIN1 – PIN6	PIN 7&8	PIN 9 & 10
7.0V - 14.0 V	Open	Short	Short

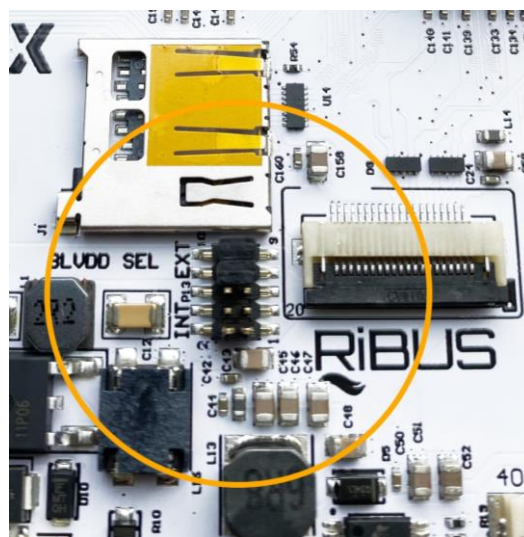

Figure 6. External backlight jumper setting



### 10.9 Expansion connector

The main board has one 1.27mm, 40-pin expansion pin header which is labeled as “EXPANSION CONNECTOR’ (P8).

It provides direct access to below GPIOs of MCU STM32H757XIH6, which make it possible to easily extend a daughterboard for a specific application.

- 2 x I<sup>2</sup>C
- 1 x UART
- 1 x USART
- 1 x SPI
- 1 x USB
- 7 x PWMs
- 2 x DACs (Digital-to-analog)
- 2 x ADCs (Analog-to-digital)

Each of the GPIO pins can be configured by software as output (push-pull or open-drain, with or without pull-up or pull-down), as input (floating, with or without pull-up or pull-down) or as peripheral alternate function. Most of the GPIO pins are shared with digital or analog alternate functions. Please refer to the datasheet of STM32H757XIH6 for more details.

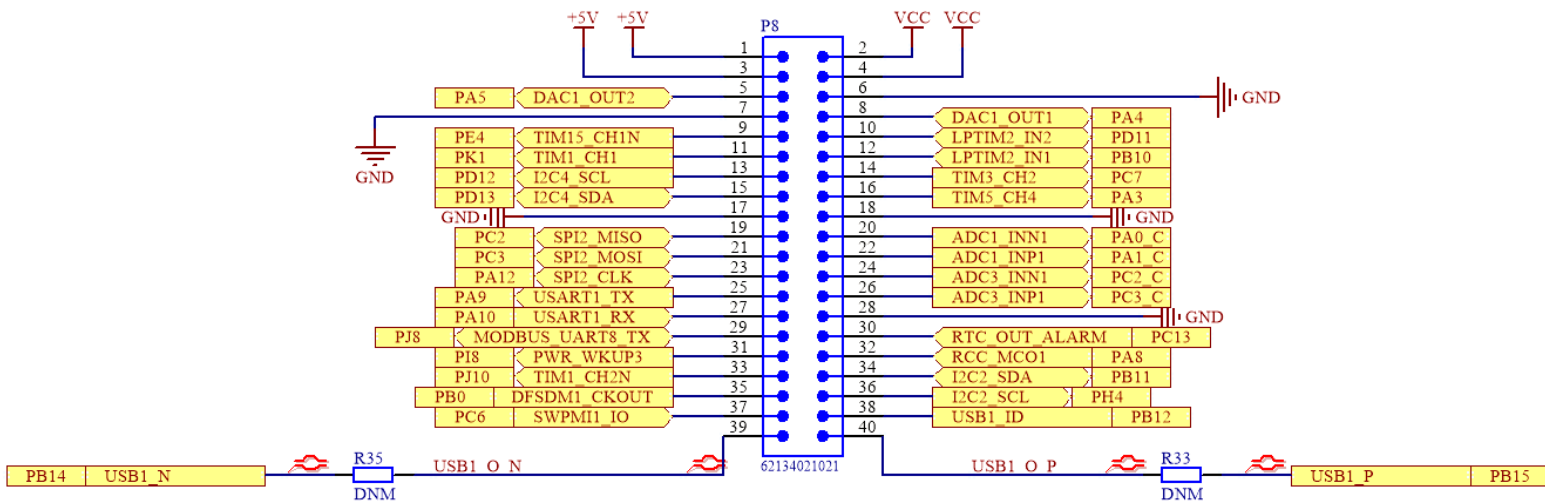

I/O/P	PIN NAME	NO.	NO.	PIN NAME	I/O/P
P	VCC_+5V	1	2	VCC_+3.3V	P
P	VCC_+5V	3	4	VCC_+3.3V	P
I/O	PA5	5	6	GND	P
P	GND	7	8	PA4	I/O
I/O	PE4	9	10	PD11	I/O
I/O	PK1	11	12	PB10	I/O
I/O	PD12	13	14	PC7	I/O
I/O	PD13	15	16	PA3	I/O
P	GND	17	18	GND	P
I/O	PC2	19	20	PA0_C	I/O



I/O	PC3	21	22	PA1_C	I/O
I/O	PA12	23	24	PC2_C	I/O
I/O	PA9	25	26	PC3_C	I/O
I/O	PA10	27	28	GND	P
I/O	PJ8	29	30	PC13	I/O
I/O	P18	31	32	PA8	I/O
I/O	PJ10	33	34	PB11	I/O
I/O	PB0	35	36	PH4	I/O
I/O	PC6	37	38	PB12	I/O
I/O	PB14	39	40	PB15	I/O

**Note 1.** The total output current  $I@5.0V$  from pin 1 and pin3 is maximum 1A.

The total output current  $I@3.3V$  from pin 2 and pin 4 is maximum 500mA.

**Note 2.** The 'USR LED' is connected to pin 33, PJ10, of the expansion connector.

By default, the resistor R60, (0402, 1k ohms) is soldered. Please remove R60 to use GPIO channel PJ10.

**Note 3.** Push button BTN2(S2) is connected to pin 35, PB0. Push button BTN1(S1) is connected to pin 37, PC6. To use GPIO channel PB0 and PC6, R57 and R58 should be removed. Please refer to the schematic of subchapter 11.1.

### 10.10 Micro SD card slot

The mainboard is equipped with Micro-SD slot, which supports all types of Micro SD cards.

### 10.11 2 x 20-pin, 1.27 mm pin sockets for POE Add-on Board

The 2 x 20-pin, 1.27 mm, pin sockets, labeled as U9a and U9b, are used to connect the Riverdi POE Add-on Board.

The Riverdi POE Add-on Board features 10/100M Ethernet Port with Power-Over-Ethernet enabled. It allows you to power the module through the Ethernet port.

**Note.** The Riverdi POE Add-on Board is offered as an accessory.

### 10.12 Battery coin cell holder

The battery coin cell, labeled as BT1, is suitable for CR1220 (Ø12.5 x 2.0mm) Coin Cell Batteries.

The BT1 is connected to the VBAT pin of STM32H757XIH6, which allows to retain the content of the backup registers, SDRAM, and to keep running RTC when the VDD\_IN is turned off and unplugged.



## 11. USER INTERFACES

### 11.1 3 x push buttons

Push button labeled as “RST” is used to “RESET” the module.

Another 2 push buttons labeled as BTN1, BTN2 are for user’s development.

- BTN1(S1) is connected to pin 37, PC6, of the expansion connector.
- BTN2(S2) is connected to pin 35, PB0, of the expansion connector.

By default, pushbuttons BTN1(S1), BTN2(S2) are enabled. To use GPIO channel PC6 and PB0, R57 (0402, 0 ohm) and R58 (0402, 0 ohm) should be removed.

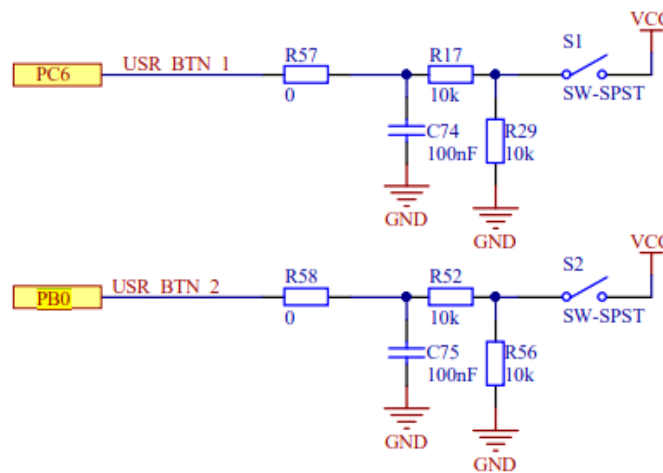

### 11.2 3 x LEDs

1 x LED, labeled as ‘PWR LED’, emits green light when the modules is powered.

1 x LED, labeled as ‘USB OVR’, emits red light when VCC\_USB pin overcurrent occurs.

1 x LED, labeled as ‘USR LED’, is for user’s development.

- The ‘USR LED’ is connected to pin 33, PJ10, of the expansion connector.

By default, the resistor R60, (0402, 1k ohms) is soldered. Please remove R60 to use GPIO channel PJ10.

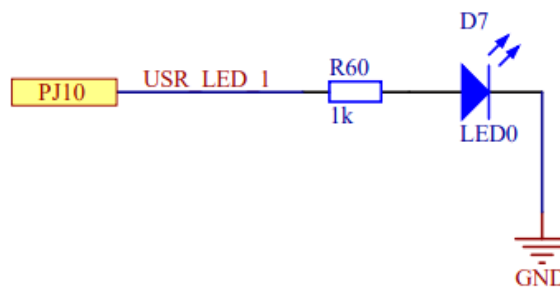



## 12.DISPLAY SEPCIFICATION

### 12.1 Full TFT specification

The TFT of the module applies Riverdi high brightness, IPS, 7.0" MIPI TFT: RVT70HSMNWC00

For detailed information on the display, please refer to datasheet of display.

## 13.CAPACITIVE TOUCH SCREEN PANEL SPECIFICATIONS

### 13.1 Mechanical characteristics

DESCRIPTION	SPECIFICATION	REMARK
Touch Panel Size	7.0 inch	uxTouch
Outline Dimension of CTP	179.96 mm x 119.00 mm	
Product Thickness	2.45 mm	
Glass Thickness	1.1 mm	
CTP View Area	155.01 mm x 86.72 mm	
Sensor Active Area	156.08 mm x 88.42 mm	
Surface Hardness	7H	

### 13.2 Electrical characteristics

DESCRIPTION		SPECIFICATION	REMARK
Power Consumption (IDD)	Active Mode	90 mA	
	Sleep Mode	10 mA	
Linearity		+/- 1.5mm	
Controller		ILI2132A	
Resolution		1024 x 600	

## 14. INSPECTION

Standard acceptance/rejection criteria for TFT module

### 14.1 Inspection condition

Ambient conditions:

- Temperature:  $25 \pm 2^\circ\text{C}$
- Humidity:  $(60 \pm 10) \%RH$
- Illumination: Single fluorescent lamp non-directive (300 to 700 lux)

Viewing distance:  $35 \pm 5\text{cm}$  between inspector bare eye and LCD.

Viewing Angle: U/D:  $45^\circ/45^\circ$ , L/R:  $45^\circ/45^\circ$

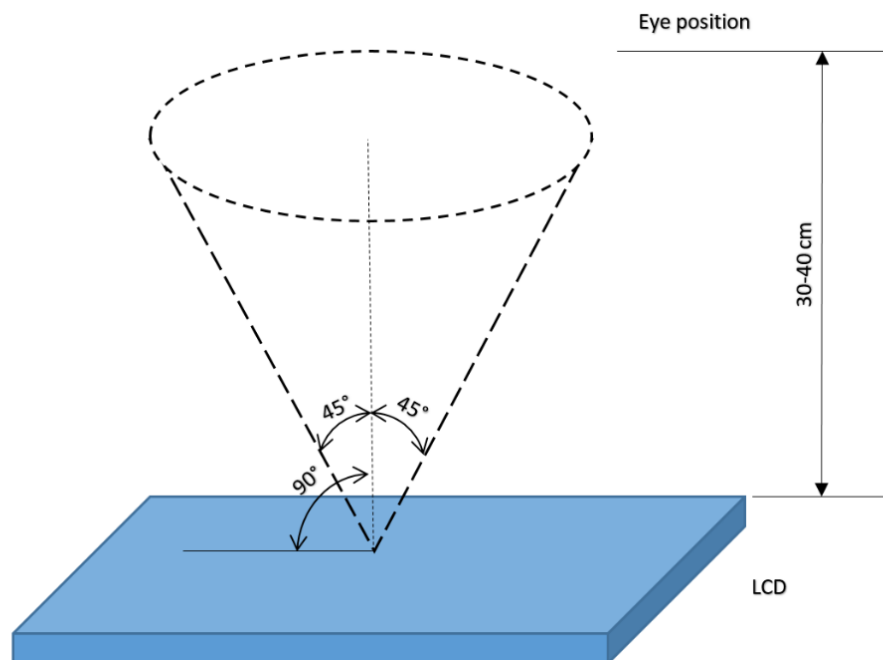

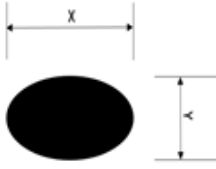
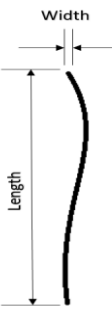

14.2 Inspection standard

ITEM		CRITERION		
Black spots, white spots, light leakage, Foreign Particle (round Type)	 <p><math>D=(x+y)/2</math> Spot's density: 10 mm</p>	Size = 7"		
		Average Diameter	Qualified Qty	
		$D \leq 0.2 \text{ mm}$	Ignored	
		$0.2 \text{ mm} < D \leq 0.3 \text{ mm}$	N≤3	
		$0.5\text{mm} < D$	Not allowed	
LCD black spots, white spots, light leakage (line Type)		Size = 7"		
		Length	Width	Qualified Qty
		-	$W \leq 0.05$	Ignored
		$L \leq 5.0$	$0.05 < W \leq 0.1$	3
Bright/Dark Dots	Size = 7"			
	Item	Qualified Qty		
	Bright dots	N≤2		
	Dark dots	N≤3		
Clear spots	Size = 7"			
	Average Diameter	Qualified Qty		
	$D < 0.2 \text{ mm}$	Ignored		
	$0.2 \text{ mm} < D < 0.3 \text{ mm}$	4		
	$0.3 \text{ mm} < D < 0.5 \text{ mm}$	2		
Polarizer bubbles	Size = 7"			
	Average Diameter	Qualified Qty		
	$D \leq 0.2 \text{ mm}$	Ignored		
	$0.2 \text{ mm} < D \leq 0.5 \text{ mm}$	4		
Touch panel spot	Size ≥ 5"			
	Average Diameter	Qualified Qty		
	$D < 0.25 \text{ mm}$	Ignored		
	$0.25 \text{ mm} < D < 0.5 \text{ mm}$	4		
Touch panel White line Scratch	Size ≥ 5"			
	Length	Width	Qualified Qty	
	-	$W < 0.03$	Ignored	
	$L < 5.0$	$0.03 < W < 0.05$	2	
-	$0.05 < W$	0		



## 15. RELIABILITY TEST

NO.	TEST ITEM	TEST CONDITION	NOTE
1	High Temperature Storage	80°C/120 hours	Note 1
2	Low Temperature Storage	-30°C/120 hours	
3	High Temperature Operating	70 °C /120 hours	
4	Low Temperature Operating	-20°C/120 hours	
5	High Temperature and High Humidity	Humidity 40°C, 90%RH, 120Hrs	
6	Thermal Cycling Test (No operation)	-20°C for 30mins, 70°C for 30 mins. 100 cycles. Then test at room temperature after 1 hour	Note 2
7	Vibration Test	Frequency: 10 ÷ 55 Hz. Stroke: 1.5 mm. Sweep: 10Hz ÷ 55Hz ÷ 10 Hz. 2 hours for each direction of X, Y, Z (Total 6 hours)	
8	Package Drop Test	Height: 60 cm 1 corner, 3 edges, 6 surfaces	

**Note 1.** Sample quantity for each test item is 5 ÷ 10 pcs.

**Note 2.** Before cosmetic and function test, the product must have enough recovery time, at least 2 hours at room temperature.



## 16.LEGAL INFORMATION

CE marking is usually obligatory only for a complete end product. Riverdi display modules are semi-finished goods which are used as inputs to become part of the finished products.

Therefore, Riverdi display modules are not CE marked.

Riverdi grants the guarantee for the proper operation of the goods for a period of 12 months from the date of possession of the goods. If in a consequence of this guaranteed execution the customer has received the defects-free item as replacement for the defective item, the effectiveness period of this guarantee shall start anew from the moment the customer receives the defects-free item.

Information about device is the property of Riverdi and may be the subject of patents pending or granted. It is not allowed to copy or disclosed this document without prior written permission.

Riverdi endeavors to ensure that all contained information in this document is correct but does not accept liability for any error or omission. Riverdi products are in developing process and published information may be not up to date. Riverdi reserves the right to update and makes changes to Specifications or written material without prior notice at any time. It is important to check the current position with Riverdi.

Images and graphics used in this document are only for illustrative the purpose. All images and graphics are possible to be displayed on the range products of Riverdi, however the quality may vary. Riverdi is no liable to the buyer or to any third party for any indirect, incidental, special, consequential, punitive, or exemplary damages (including without limitation lost profits, lost savings, or loss of business opportunity) relating to any product, service provided or to be provided by Riverdi, or the use or inability to use the same, even if Riverdi has been advised of the possibility of such damages.

Riverdi products are not fault tolerant nor designed, manufactured or intended for use or resale as on line control equipment in hazardous environments requiring fail-safe performance, such as in the operation of nuclear facilities, aircraft navigation or communication systems, air traffic control, direct life support machines or weapons systems in which the failure of the product could lead directly to death, personal injury or severe physical or environmental damage ('High-Risk Activities'). Riverdi and its suppliers specifically disclaim any expressed or implied warranty of fitness for High-Risk Activities. Using Riverdi products and devices in 'High-Risk Activities' and in any other application is entirely at the buyer's risk, and the buyer agrees to defend, indemnify, and hold harmless Riverdi from all damages, claims or expenses resulting from such use. No licenses are conveyed, implicitly or otherwise, under any Riverdi intellectual property rights.



Hi, I am here to help you!  
If you have any additional  
questions, please contact  
our support via email:  
[contact@riverdi.com](mailto:contact@riverdi.com)

