



WINSTAR Display Co.,Ltd.
華凌光電股份有限公司



Winstar Display Co., LTD

華凌光電股份有限公司



WEB: <https://www.winstar.com.tw> E-mail: sales@winstar.com.tw

SPECIFICATION

CUSTOMER : _____

MODULE NO.: WF101GTYAPLNNO#

| | |
|---|--|
| <p>APPROVED BY:</p> <p>(FOR CUSTOMER USE ONLY)</p> | <p>PCB VERSION: _____</p> <p>DATA: _____</p> |
|---|--|

| SALES BY | APPROVED BY | CHECKED BY | PREPARED BY |
|--------------------------------|-------------|------------|-------------|
| | | | 周园园 |
| ISSUED DATE: 2019/01/18 | | | |



RECORDS OF REVISION

DOC. FIRST ISSUE

| VERSION | DATE | REVISED PAGE NO. | SUMMARY |
|---------|------------|------------------|---|
| 0 | 2017/11/24 | | First issue |
| A | 2018/08/29 | | Add Uniformity Modify Current Consumption & Power Sequence |
| B | 2019/01/18 | | Modify contour drawing |

WINSTAR DISPLAY CO., LTD.

Contents

- 1.Module Classification Information
- 2.Summary
- 3.General Specification
- 4.Absolute Maximum Ratings
- 5.Electrical Characteristics
- 6.Interface Timing Characteristics
- 7.Optical Characteristics
- 8.Interface
- 9.Reliability
- 10.Contour Drawing
- 11.Other

WINSTAR DISPLAY Co., Ltd.

1.Module Classification Information

W F 101 G T Y A P L N N 0 #
 ① ② ③ ④ ⑤ ⑥ ⑦ ⑧ ⑨ ⑩ ⑪ ⑫ ⑬

| | | | | | | | | | | | | |
|---|---|---|--|---------|---|--|----|------------------------------------|---------------|--------------------------------|---|---------|
| ① | Brand : WINSTAR DISPLAY CORPORATION | | | | | | | | | | | |
| ② | Display Type : F→TFT Type, J→Custom TFT | | | | | | | | | | | |
| ③ | Display Size : 10.1” TFT | | | | | | | | | | | |
| ④ | Model serials no. | | | | | | | | | | | |
| ⑤ | Backlight Type : | F→CCFL, White S→LED, High Light White | | | | T→LED, White Z→Nichia LED, White | | | | | | |
| ⑥ | LCD Polarize Type/ Temperature range/ Gray Scale Inversion Direction | A→Transmissive, N.T, IPS TFT C→Transmissive, N. T, 6:00 ; F→Transmissive, N.T,12:00 ; I→Transmissive, W. T, 6:00 K→Transflective, W.T,12:00 L→Transmissive, W.T,12:00 N→Transmissive, Super W.T, 6:00 | | | | Q→Transmissive, Super W.T, 12:00 R→Transmissive, Super W.T, O-TFT V→Transmissive, Super W.T, VA TFT W→Transmissive, Super W.T, IPS TFT X→Transmissive, W.T, VA TFT Y→Transmissive, W.T, IPS TFT Z→Transmissive, W.T, O-TFT | | | | | | |
| ⑦ | A : TFT LCD B : TFT+SCREW HOLES+CONTROL BOARD C : TFT+ SCREW HOLES +A/D BOARD D : TFT+ SCREW HOLES +A/D BOARD+CONTROL BOARD E : TFT+ SCREW HOLES +POWER BOARD | | | | F : TFT+CONTROL BOARD G : TFT+ SCREW HOLES H : TFT+D/V BOARD I : TFT+ SCREW HOLES +D/V BOARD J : TFT+POWER BD | | | | | | | |
| ⑧ | Resolution: | | | | | | | | | | | |
| | A | 128160 | B | 320234 | C | 320240 | D | 480234 | E | 480272 | F | 640480 |
| | G | 800480 | H | 1024600 | I | 320480 | J | 240320 | K | 800600 | L | 240400 |
| | M | 1024768 | N | 128128 | P | 1280800 | Q | 480800 | R | 640320 | S | 480128 |
| | T | 800320 | U | 8001280 | V | 176220 | W | 1280398 | X | 1024250 | Y | 1920720 |
| | Z | 800200 | 2 | 1024324 | 3 | 7201280 | 4 | 19201200 | 5 | 1366768 | 6 | 1280320 |
| ⑨ | D: Digital L : LVDS M:MIPI | | | | | | | | | | | |
| ⑩ | Interface: | | | | | | | | | | | |
| | N | Without control board | | | A | 8Bit | | B | 16Bit | | H | HDMI |
| | I | I2C Interface | | | R | RS232 | | S | SPI Interface | | U | USB |
| ⑪ | TS: | | | | | | | | | | | |
| | N | Without TS | | | T | Resistive touch panel | | | C | Capacitive touch panel (G-F-F) | | |
| | G | Capacitive touch panel (G-G) | | | | | C1 | Capacitive touch panel (G-F-F)+OCA | | | | |
| | C2 | Capacitive touch panel (G-F-F)+OCR | | | | | G1 | Capacitive touch panel (G-G)+OCA | | | | |
| | G2 | Capacitive touch panel (G-G)+OCR | | | | | B | CTP+GG+USB | | | | |
| ⑫ | Version: X:Raspberry pi | | | | | | | | | | | |
| ⑬ | Special Code | | #:Fit in with ROHS directive regulations | | | | | | | | | |

| | | |
|--|--|--|
| | | |
|--|--|--|

WINSTAR DISPLAY Co., Ltd.

2.Summary

TFT 10.1” is a IPS transmissive type color active matrix TFT liquid crystal display . In-Plane Switching (IPS) was one of the first refinements to produce significant gains in the light-transmissive characteristics of TFT panels. It is a technology that addresses the two main issues of a standard twisted nematic (TN) TFT display: colour and viewing angle.

WINSTAR DISPLAY Co., Ltd.

3. General Specifications

| Item | Dimension | Unit |
|------------------------------|------------------------|-------------|
| Screen Diagonal | 10.1 | inch |
| Number of Pixels | 1280 x 3(R GB) x 800 | dots |
| Module dimension | 229.34 x 148.98 x 2.5 | mm |
| Active area | 216.96 (H) x 135.6(V) | mm |
| Pixel pitch | 0.1695 x 0.1695 | mm |
| Display Mode | Normally Black | |
| Pixel Arrangement | R.G.B. Vertical Stripe | |
| Backlight Type | LED, Normally White | |
| Aspect Ratio | 16:9 | |
| Electrical Interface (Logic) | LVDS | |
| With /Without TP | Without TP | |
| Surface | Glare | |

*Color tone slight changed by temperature and driving voltage.

4. Absolute Maximum Ratings

| Item | Symbol | Min | Typ | Max | Unit |
|-----------------------|--------|-----|-----|-----|------|
| Operating Temperature | TOP | -20 | — | +70 | °C |
| Storage Temperature | TST | -20 | — | +70 | °C |

Note: Device is subject to be damaged permanently if stresses beyond those absolute maximum ratings listed above

1. Temp. $\leq 60^{\circ}\text{C}$, 90% RH MAX. Temp. $> 60^{\circ}\text{C}$, Absolute humidity shall be less than 90% RH at 60°C

WINSTAR DISPLAY Co., Ltd.

5. Electrical Characteristics

5.1. Typical Operation Conditions

(Note 1)

| Item | Symbol | Values | | | Unit | Remark |
|----------------------|--------|--------|------|------|------|--------|
| | | Min. | Typ. | MAX. | | |
| Power voltage | VDD | 2.3 | 2.5 | 2.7 | V | |
| | AVDD | 8.0 | 8.2 | 8.4 | V | |
| | VGH | 21.7 | 22 | 22.3 | V | |
| | VGL | -7.3 | -7 | -6.7 | V | |
| Input signal voltage | VCOM | 2.7 | 3.0 | 3.3 | V | Note 2 |

Note 1: Be sure to apply VDD and VGL to the LCD first, and then apply VGH.

Note 2: Typical VCOM is only a reference value, it must be optimized according to each LCM. Be sure to use VR.

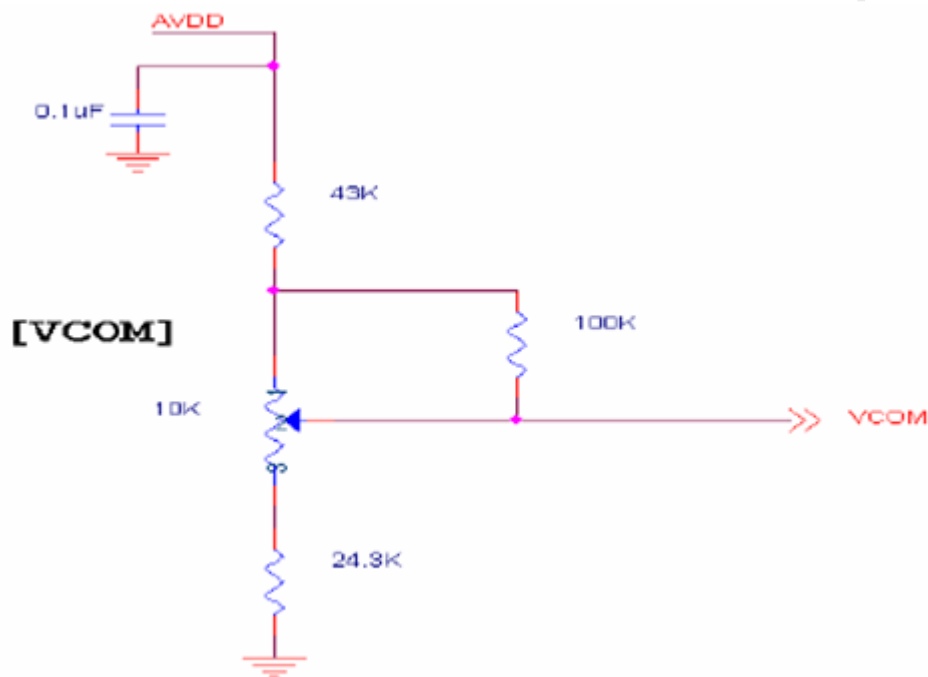

5.2. Current Consumption

| Item | Symbol | Values | | | Unit | Remark |
|--------------------|--------|--------|------|------|------|-----------|
| | | Min. | Typ. | MAX. | | |
| Current for Driver | IGH | 300 | 705 | 1000 | uA | VGH =22V |
| | IGL | 300 | 705 | 1000 | uA | VGL = -7V |
| | IVDD | 50 | 95 | 120 | mA | VDD =2.5V |
| | IAVDD | 8 | 45 | 70 | mA | AVDD=8.2V |

5.3. Power Sequence

a. Power on:

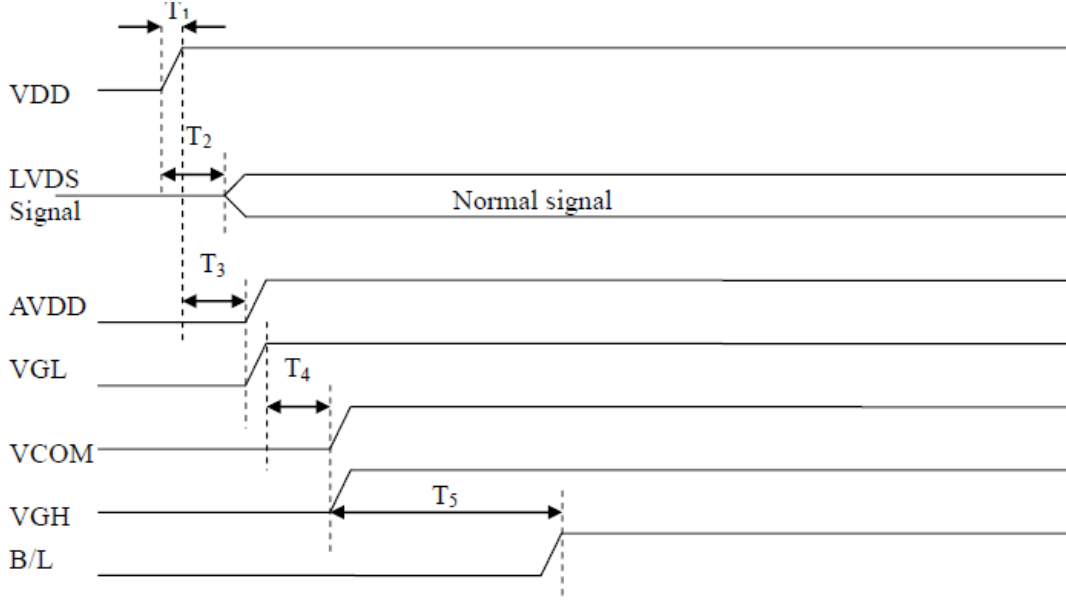

| Item | Values | | | Unit |
|------|--------|------|------|------|
| | Min. | Typ. | MAX. | |
| T1 | 0.5 | 2 | 10 | ms |
| T2 | 0 | 5 | 50 | ms |
| T3 | 0 | 5 | 50 | ms |
| T4 | 0 | 6 | 100 | ms |
| T5 | 120 | 130 | 200 | ms |

b. Power off:

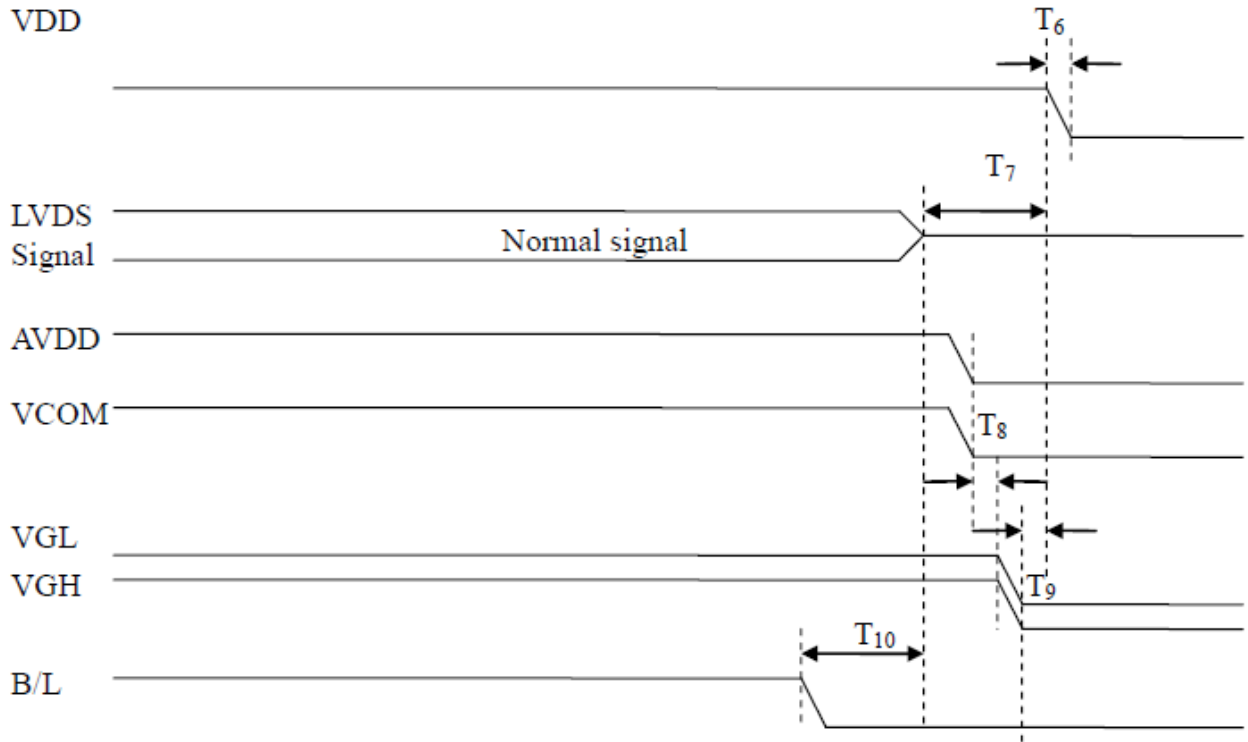

| Item | Values | | | Unit |
|------|--------|------|------|------|
| | Min. | Typ. | MAX. | |
| T6 | 0.5 | 2 | 10 | ms |
| T7 | 0 | 7 | 50 | ms |
| T8 | 0 | 5 | 10 | ms |
| T9 | 0 | 1 | 10 | ms |
| T10 | 0 | 2 | 100 | ms |

5.4. Backlight Characteristics

| Parameter | Symbol | Min. | Typ. | Max. | Unit | Remark |
|---------------------------------------|--------|-------|------|------|------|--------|
| Supply voltage of white LED backlight | VL | 8.6 | 9.6 | 10.2 | V | Note 1 |
| Current for LED backlight | IL | — | 220 | — | mA | |
| LED life time | - | 50000 | - | - | Hr | Note 1 |

Note 1 : There are 1 Groups LED

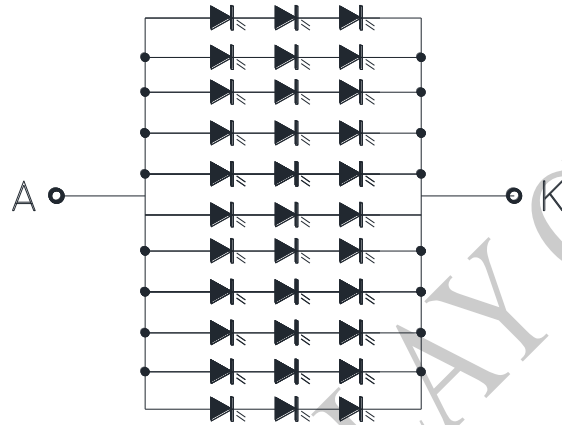

Note 2 : $T_a = 25\text{ }^\circ\text{C}$

Note 3 : Brightness to be decreased to 50% of the initial value

Note 4 : The single LED lamp case

6.LVDS Signal Timing Characteristics

6.1. AC Electrical Characteristics

| Parameter | Symbol | Values | | | Unit | Remark |
|--|--------|--------|------|------|------|----------------|
| | | Min. | Typ. | MAX. | | |
| LVDS Differential input high Threshold voltage | RxVTH | - | - | +100 | mV | RXVCM=1.2 V |
| LVDS Differential input low Threshold voltage | RxVTL | -100 | - | - | mV | |
| LVDS Differential input common mode voltage | RxVCM | 0.7 | - | 1.6 | V | |
| LVDS Differential voltage | VID | 200 | - | 600 | mV | |

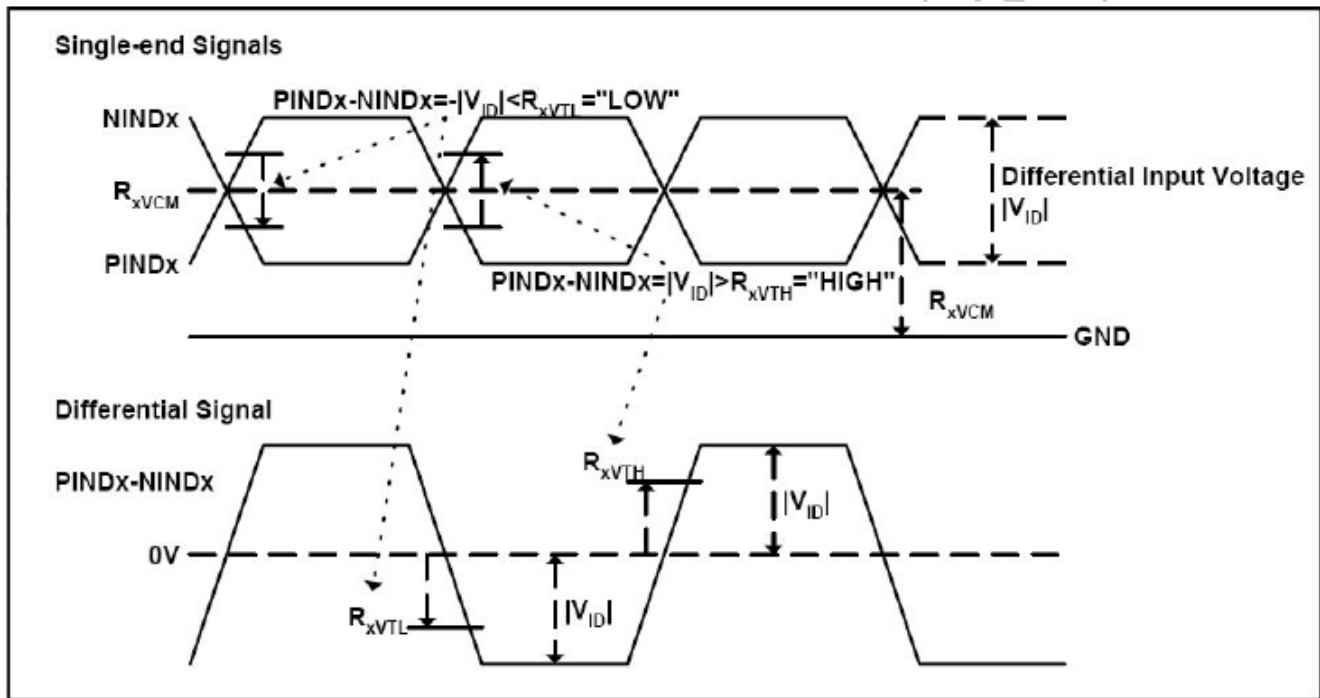

6.2. Timing Table

| Parameter | Symbol | Value | | | Unit | Remark |
|--------------------------------------|--------------------|-------|------|------|------|------------------|
| | | Min. | Typ. | Max. | | |
| Clock Frequency | 1/Tc | 68.9 | 71.1 | 73.4 | Mhz | Frame rate =60Hz |
| Horizontal display area | thd | 1280 | | | Tc | |
| HS period time | th | 1410 | 1440 | 1470 | Tc | |
| HS Width +Back Porch +Front Porch | tHW+ tHBP +tHFP | 60 | 160 | 190 | Tc | |
| Vertical display area | tvd | 800 | | | tH | |
| VS period time | tv | 815 | 823 | 833 | tH | |
| VS Width +Back Porch +Front Porch | tvW+ tvBP +tvFP | 15 | 23 | 33 | tH | |

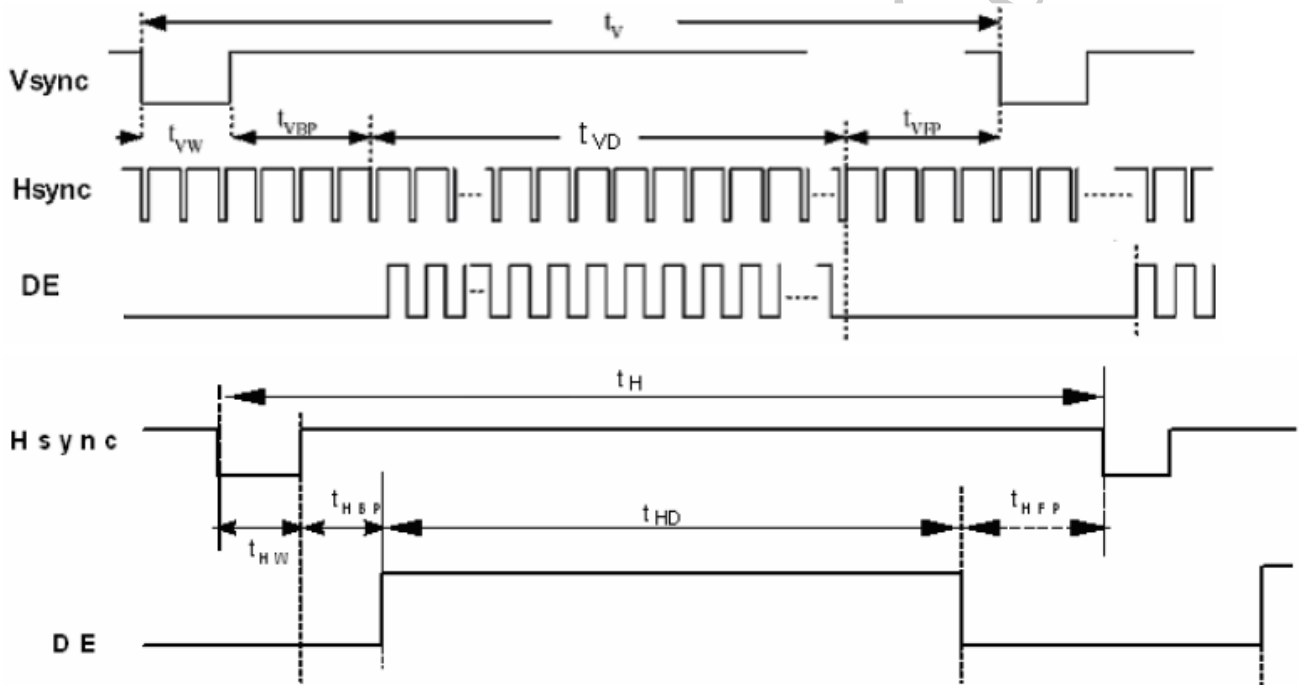

6.3. LVDS Data Input Format

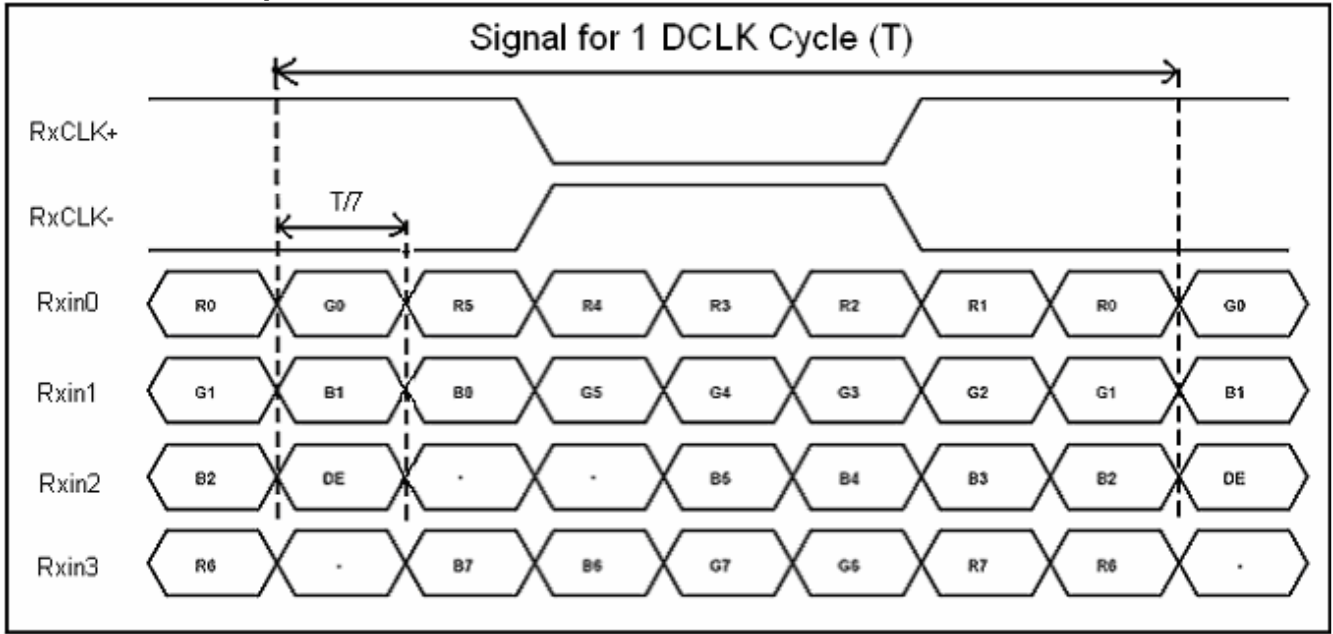

WINSTAR DISPLAY

7. Optical Characteristics

| Item | Symbol | Condition. | Min | Typ. | Max. | Unit | Remark | |
|--------------------|--------|-----------------------------------|-----------------------------------|------|------|-------------------|-------------------|------------|
| Response time | Tr | $\theta=0^\circ$ 、 $\phi=0^\circ$ | - | 10 | 20 | .ms | Note 3 | |
| | Tf | | - | 15 | 30 | | | |
| Contrast ratio | CR | At optimized viewing angle | 600 | 800 | - | - | Note 4 | |
| Color Chromaticity | White | Wx | $\theta=0^\circ$ 、 $\phi=0^\circ$ | 0.26 | 0.31 | 0.36 | - | Note 2,6,7 |
| | | Wy | | 0.28 | 0.33 | 0.38 | - | |
| Viewing angle | Hor. | θ_R | $CR \geq 10$ | 75 | 85 | - | Deg. | Note 1 |
| | | θ_L | | 75 | 85 | - | | |
| | Ver. | ϕ_T | | 75 | 85 | - | | |
| | | ϕ_B | | 75 | 85 | - | | |
| Brightness | - | - | 350 | - | - | cd/m ² | Center of display | |
| Uniformity | (U) | - | 70 | - | - | % | Note 5 | |

Ta=25±2°C

Note 1: Definition of viewing angle range

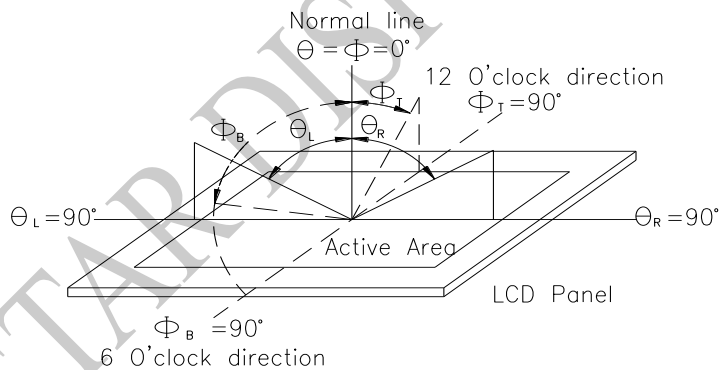

Fig. 7.1. Definition of viewing angle

Note 2: Test equipment setup:

After stabilizing and leaving the panel alone at a driven temperature for 10 minutes, the measurement should be executed. Measurement should be executed in a stable, windless, and dark room. Optical specifications are measured by Topcon BM-7 or BM-5 luminance meter 1.0° field of view at a distance of 50cm and normal direction.

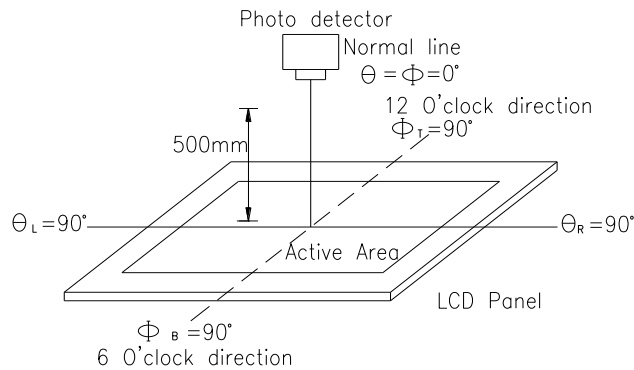
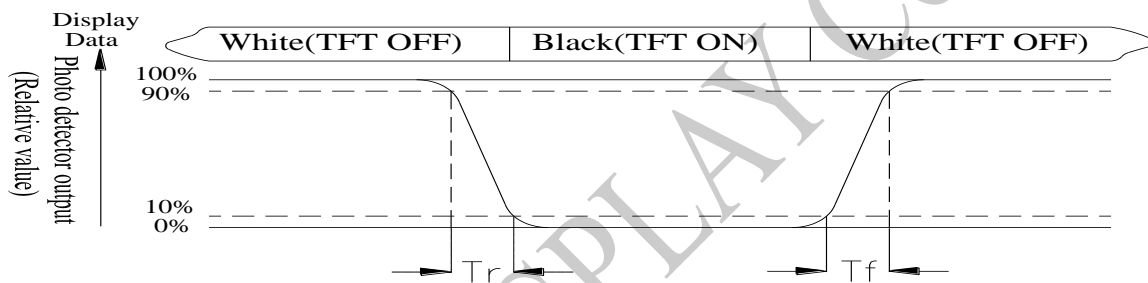

Fig. 7.2. Optical measurement system setup

Note 3: Definition of Response time:

The response time is defined as the LCD optical switching time interval between “White” state and “Black” state. Rise time, T_r , is the time between photo detector output intensity changed from 90% to 10%. And fall time, T_f , is the time between photo detector output intensity changed from 10% to 90%



Note 4: Definition of contrast ratio:

The contrast ratio is defined as the following expression.

$$\text{Contrast ratio (CR)} = \frac{\text{Luminance measured when LCD on the "White" state}}{\text{Luminance measured when LCD on the "Black" state}}$$

Note 5: Definition of Luminance Uniformity

Active area is divided into 9 measuring areas (reference the picture in below). Every measuring point is placed at the center of each measuring area.

$$\text{Luminance Uniformity (U)} = \text{Lmin/Lmax} \times 100\%$$

L = Active area length

W = Active area width

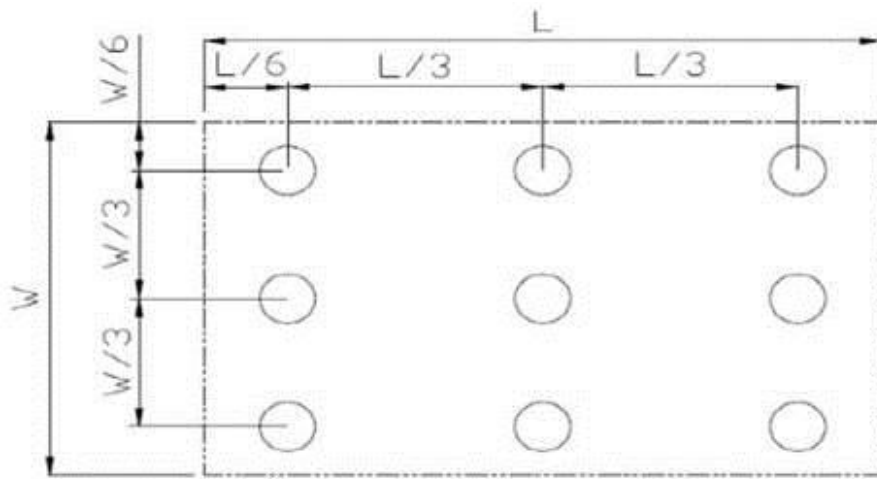

Fig7.3. Definition of uniformity

Note 6: Definition of color chromaticity (CIE 1931)
Color coordinates measured at the center point of LCD

Note 7: Measured at the center area of the panel when all the input terminals of LCD panel are electrically opened.

WINSTAR DISPLAY Co., Ltd.

8.Interface

Interface Connector

A 40pin connector is used for the module electronics interface. The recommended model is F62240-H1210B manufactured by Vigorconn.

| Pin No. | Symbol | I/O | Function | Remark |
|---------|--------|-----|--------------------------------|-----------------------|
| 1 | VCOM | P | Common Voltage | |
| 2 | VDD | P | Power Supply | |
| 3 | VDD | P | Power Supply | |
| 4 | NC | - | No connection | |
| 5 | NC | - | No connection | |
| 6 | NC | - | No connection | |
| 7 | GND | P | Ground | |
| 8 | Rxin0- | I | -LVDS Differential Data Input | R0-R5,G0 |
| 9 | Rxin0+ | I | +LVDS Differential Data Input | |
| 10 | GND | P | Ground | |
| 11 | Rxin1- | I | -LVDS Differential Data Input | G1G5,B0,B1 |
| 12 | Rxin1+ | I | +LVDS Differential Data Input | |
| 13 | GND | P | Ground | |
| 14 | Rxin2- | I | -LVDS Differential Data Input | B2-B5,HS,VS, DE |
| 15 | Rxin2+ | I | +LVDS Differential Data Input | |
| 16 | GND | P | Ground | |
| 17 | RxCLK- | I | -LVDS Differential Clock Input | LVDS CLK |
| 18 | RxCLK+ | I | +LVDS Differential Clock Input | |
| 19 | GND | P | Ground | |
| 20 | Rxin3- | I | -LVDS Differential Data Input | R6,R7,G6,G7, B6,B7 |
| 21 | Rxin3+ | I | +LVDS Differential Data Input | |
| 22 | GND | P | Ground | |
| 23 | NC | - | No connection | |
| 24 | NC | - | No connection | |
| 25 | GND | P | Ground | |
| 26 | NC | - | No connection | |
| 27 | NC | - | No connection | |
| 28 | NC | - | No connection | |
| 29 | AVDD | P | Power for Analog Circuit | |

| | | | | |
|----|------|---|------------------|--|
| 30 | GND | P | Ground | |
| 31 | LED- | P | LED Cathode | |
| 32 | LED- | P | LED Cathode | |
| 33 | NC | - | No connection | |
| 34 | NC | - | No connection | |
| 35 | VGL | P | Gate OFF Voltage | |
| 36 | NC | - | No connection | |
| 37 | NC | - | No connection | |
| 38 | VGH | P | Gate ON Voltage | |
| 39 | LED+ | P | LED Anode | |
| 40 | LED+ | P | LED Anode | |

I: input, O: output, P: Power

WINSTAR DISPLAY Co., Ltd.

9. Reliability

Content of Reliability Test (Wide temperature, -20°C ~70°C)

| Environmental Test | | | |
|---|---|---|------|
| Test Item | Content of Test | Test Condition | Note |
| High Temperature storage | Endurance test applying the high storage temperature for a long time. | 70°C 200hrs | 2 |
| Low Temperature storage | Endurance test applying the low storage temperature for a long time. | -20°C 200hrs | 1,2 |
| High Temperature Operation | Endurance test applying the electric stress (Voltage & Current) and the thermal stress to the element for a long time. | 70°C 200hrs | — |
| Low Temperature Operation | Endurance test applying the electric stress under low temperature for a long time. | -20°C 200hrs | 1 |
| High Temperature/ Humidity Operation | The module should be allowed to stand at 60 °C, 90%RH max | 60°C, 90%RH 96hrs | 1,2 |
| Thermal shock resistance | The sample should be allowed stand the following 10 cycles of operation <div style="text-align: center;"> <p style="text-align: center;">-20°C 25°C 70°C 30min 5min 30min 1 cycle</p> </div> | -20°C/70°C 10 cycles | — |
| Vibration test | Endurance test applying the vibration during transportation and using. | Total fixed amplitude : 1.5mm Vibration Frequency : 10~55Hz One cycle 60 seconds to 3 directions of X, Y, Z for Each 15 minutes | 3 |
| Static electricity test | Endurance test applying the electric stress to the terminal. | VS=±600V(contact), ±800v(air), RS=330 Ω CS=150pF 10 times | — |

Note1: No dew condensation to be observed.

Note2: The function test shall be conducted after 4 hours storage at the normal Temperature and humidity after remove from the test chamber.

Note3: The packing have to including into the vibration testing.

10. Contour Drawing

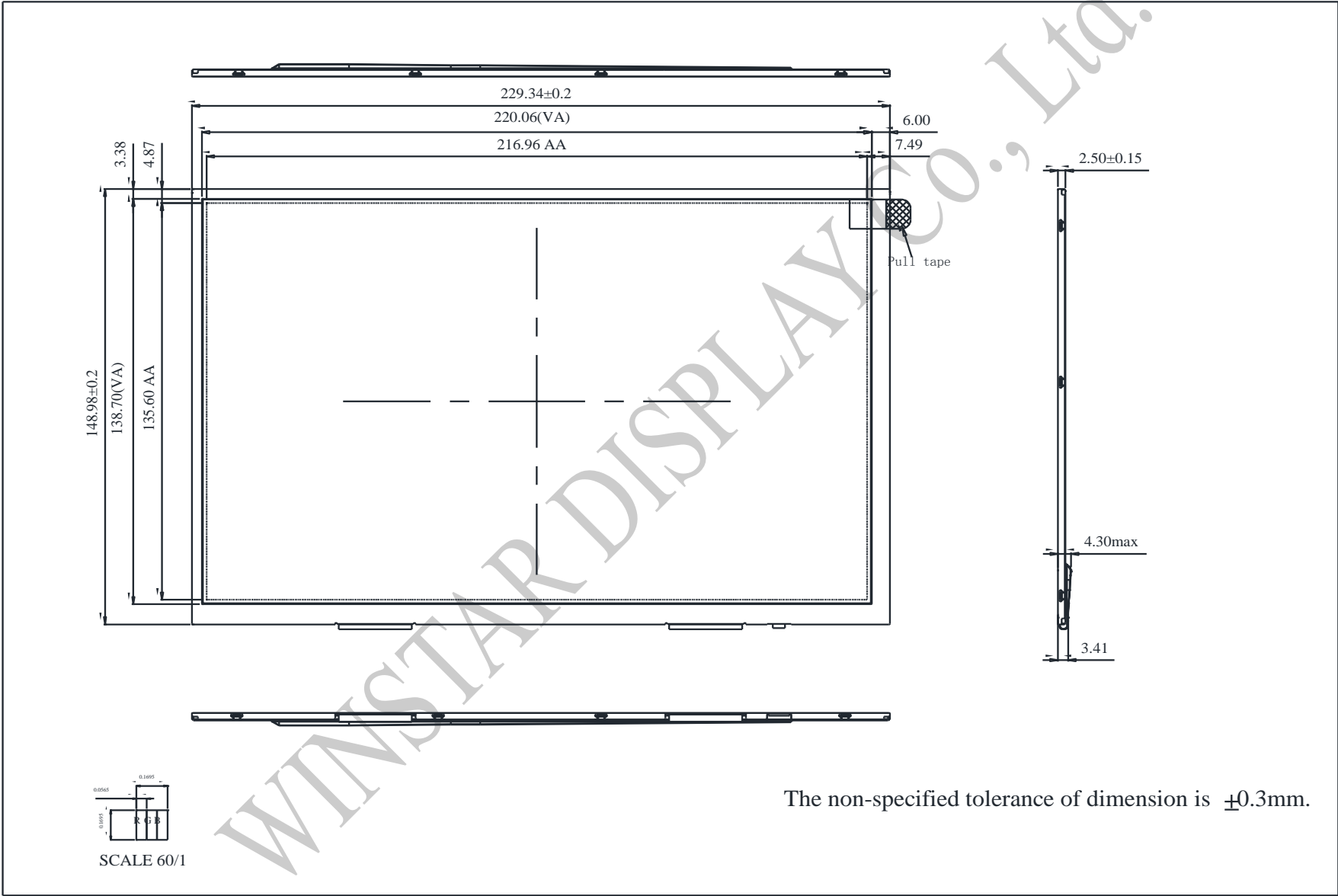

| PIN NO. | SYMBOL | PIN NO. | SYMBOL |
|---------|--------|---------|--------|
| 1 | VCOM | 21 | Rxin3+ |
| 2 | VDD | 22 | GND |
| 3 | VDD | 23 | NC |
| 4 | NC | 24 | NC |
| 5 | NC | 25 | GND |
| 6 | NC | 26 | NC |
| 7 | GND | 27 | NC |
| 8 | Rxin0- | 28 | NC |
| 9 | Rxin0+ | 29 | AVDD |
| 10 | GND | 30 | GND |
| 11 | Rxin1- | 31 | LED- |
| 12 | Rxin1+ | 32 | LED- |
| 13 | GND | 33 | NC |
| 14 | Rxin2- | 34 | NC |
| 15 | Rxin2+ | 35 | VGL |
| 16 | GND | 36 | NC |
| 17 | RxCLK- | 37 | NC |
| 18 | RxCLK+ | 38 | VGH |
| 19 | GND | 39 | LED+ |
| 20 | Rxin3- | 40 | LED+ |

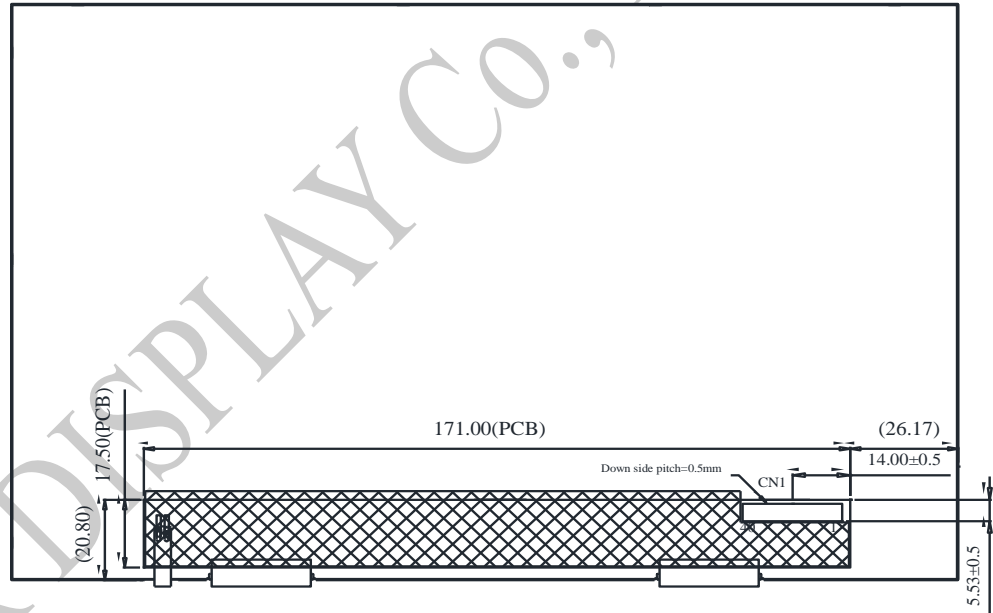

The non-specified tolerance of dimension is $\pm 0.3\text{mm}$.



1、Panel Specification :

- 1. Panel Type : Pass NG , _____
- 2. View Direction : Pass NG , _____
- 3. Numbers of Dots : Pass NG , _____
- 4. View Area : Pass NG , _____
- 5. Active Area : Pass NG , _____
- 6. Operating : Pass NG , _____
- 7. Storage Temperature : Pass NG , _____
- 8. Others : _____

2、Mechanical

- 1. PCB Size : Pass NG , _____
- 2. Frame Size : Pass NG , _____
- 3. Material of Frame : Pass NG , _____
- 4. Connector Position : Pass NG , _____
- 5. Fix Hole Position : Pass NG , _____
- 6. Backlight Position : Pass NG , _____
- 7. Thickness of PCB : Pass NG , _____
- 8. Height of Frame to PCB : Pass NG , _____
- 9. Height of Module : Pass NG , _____
- 10. Others : Pass NG , _____

3、Relative Hole Size :

- 1. Pitch of Connector : Pass NG , _____
- 2. Hole size of Connector : Pass NG , _____
- 3. Mounting Hole size : Pass NG , _____
- 4. Mounting Hole Type : Pass NG , _____
- 5. Others : Pass NG , _____

4、Backlight Specification :

- 1. B/L Type : Pass NG , _____
- 2. B/L Color : Pass NG , _____
- 3. B/L Driving Voltage (Reference for LED) : Pass NG , _____
- 4. B/L Driving Current : Pass NG , _____
- 5. Brightness of B/L : Pass NG , _____
- 6. B/L Solder Method : Pass NG , _____
- 7. Others : Pass NG , _____



Winstar Module Number : _____

Page: 2

5、Electronic Characteristics of Module :

- | | | |
|------------------------------|-------------------------------|-------------------------------------|
| 1. Input Voltage : | <input type="checkbox"/> Pass | <input type="checkbox"/> NG , _____ |
| 2. Supply Current : | <input type="checkbox"/> Pass | <input type="checkbox"/> NG , _____ |
| 3. Driving Voltage for LCD : | <input type="checkbox"/> Pass | <input type="checkbox"/> NG , _____ |
| 4. Contrast for LCD : | <input type="checkbox"/> Pass | <input type="checkbox"/> NG , _____ |
| 5. B/L Driving Method : | <input type="checkbox"/> Pass | <input type="checkbox"/> NG , _____ |
| 6. Negative Voltage Output : | <input type="checkbox"/> Pass | <input type="checkbox"/> NG , _____ |
| 7. Interface Function : | <input type="checkbox"/> Pass | <input type="checkbox"/> NG , _____ |
| 8. LCD Uniformity : | <input type="checkbox"/> Pass | <input type="checkbox"/> NG , _____ |
| 9. ESD test : | <input type="checkbox"/> Pass | <input type="checkbox"/> NG , _____ |
| 10. Others : | <input type="checkbox"/> Pass | <input type="checkbox"/> NG , _____ |

6、Summary :

Sales signature : _____

Customer Signature : _____

Date : / / _____

