



Winstar Display Co., LTD

華凌光電股份有限公司



WEB: <http://www.winstar.com.tw>

E-mail: winstar@winstar.com.tw

SPECIFICATION

CUSTOMER : _____

MODULE NO.: WF102ATIAGDNGO#

<p>APPROVED BY:</p> <p>(FOR CUSTOMER USE ONLY)</p>	<p>PCB VERSION: _____</p> <p>DATA: _____</p>
-------------------------------------------------------------	------------------------------------------------------------

SALES BY	APPROVED BY	CHECKED BY	PREPARED BY
			葉虹蘭
ISSUED DATE: 2015/04/16			

TFT Display Inspection Specification: <http://www.winstar.com.tw/service.php>



RECORDS OF REVISION

DOC. FIRST ISSUE

VERSION	DATE	REVISED PAGE NO.	SUMMARY
0	2015/04/16		First issue

Contents

- 1.Module Classification Information
- 2.Summary
- 3.General Specification
- 4.Absolute Maximum Ratings
- 5.Electrical Characteristics
- 6.DC Characteristics
- 7.Interface Timing Characteristics
- 8.Optical Characteristics
- 9.Interface
- 10.Block Diagram
- 11.Reliability
- 12.Touch Panel Information
- 13.Contour Drawing
- 14.Package Specification
- 15.Other

1.Module Classification Information

W F 102 A T I A G D N G 0 #
 ① ② ③ ④ ⑤ ⑥ ⑦ ⑧ ⑨ ⑩ ⑪ ⑫ ⑬

①	Brand : WINSTAR DISPLAY CORPORATION						
②	Display Type : F→TFT Type, J→Custom TFT						
③	Display Size : 10.2" TFT						
④	Model serials no.						
⑤	Backlight Type :	F→CCFL, White S→LED, High Light White			T→LED, White		
⑥	LCD Polarize Type/ Temperature range/ Gray Scale Inversion Direction	C→Transmissive, N. T, 6:00 ; I→Transmissive, W. T, 6:00 F→Transmissive, N.T,12:00 ; L→Transmissive, W.T,12:00 N→Transmissive, Super W.T, 6:00 Q→Transmissive, Super W.T, 12:00 X→Transmissive, W.T, VA TFT V→Transmissive, Super W.T, VA TFT R→Transmissive, Super W.T, O-TFT Z→Transmissive, W.T, O-TFT A→Transmissive, N.T, IPS TFT Y→Transmissive, W.T, IPS TFT					
⑦	A : TFT LCD B : TFT+FR+CONTROL BOARD C : TFT+FR+A/D BOARD D : TFT+FR+A/D BOARD+CONTROL BOARD E : TFT+FR+POWER BOARD F : TFT+CONTROL BOARD			G : TFT+FR H : TFT+D/V BOARD I : TFT+FR+D/V BOARD J : TFT+POWER BD			
⑧	Solution:						
	A: 128160	B:320234	C:320240	D:480234	E:480272	F: 640480	G: 800480
	H:1024600	I:320480	J:240320	K:800600	L:240400	M :1024768	P :1280800
⑨	D: Digital L : LVDS						
⑩	Interface : N : without control board A : 8Bit B : 16Bit						
⑪	TS : N : Without TS T : resistive touch panel C : capacitive touch panel (G-F-F) G : capacitive touch panel(G-G)						
⑫	Version						
⑬	Special Code	#:Fit in with ROHS directive regulations					

2.Summary

This technical specification applies to 10.2' color TFT-LCD panel. The 10.2' color TFT-LCD panel is designed for camcorder, digital camera application and other electronic products which require high quality flat panel displays. This module follows RoHS.

3. General Specifications

Item	Dimension	Unit
Size	10.2	inch
Dot Matrix	800 x RGBx480(TFT)	dots
Module dimension	235 x 145.8 x 8.56	mm
Active area	222 x 132.48	mm
Dot pitch	0.0925 x 0.2775	mm
LCD type	TFT, Normally White, Transmissive	
View Direction	12 o'clock	
Gray Scale Inversion Direction	6 o'clock	
Backlight Type	LED ,Normally White	
With /Without TP	With CTP	
Surface	Glare	

*Color tone slight changed by temperature and driving voltage.

4. Absolute Maximum Ratings

Item	Symbol	Min	Typ	Max	Unit
Operating Temperature	TOP	-20	—	+70	°C
Storage Temperature	TST	-30	—	+85	°C

Note: Device is subject to be damaged permanently if stresses beyond those absolute maximum ratings listed above

1. Temp. $\leq 60^{\circ}\text{C}$, 90% RH MAX. Temp. $> 60^{\circ}\text{C}$, Absolute humidity shall be less than 90% RH at 60°C

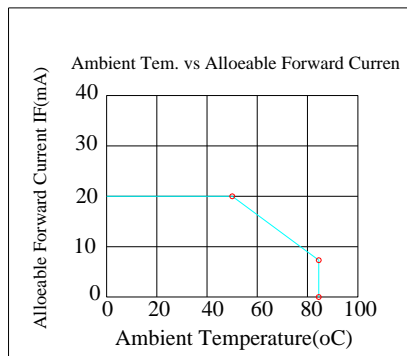

5. Electrical Characteristics

5.1. Operating conditions:

Item	Symbol	Condition	Min	Typ	Max	Unit
Supply Voltage	VCC	—	3.0	3.3	3.6	V
	AVDD	—	9.0	9.2	9.4	V
	VGH	—	15.3	16	16.7	V
	VGL	—	-7.7	-7.0	-6.3	V
Supply Voltage For Touch	VDDT	—	2.8	-	3.3	V
Input signal voltage	VCOM	—	3.65	3.85	4.05	V
	V1~V7	—	0.4 AVDD	—	AVDD-0.1	V
	V8~V14	—	0.1	—	0.6AVDD	V

5.2. LED driving conditions

Parameter	Symbol	Min.	Typ.	Max.	Unit	Remark
LED current	-	180	200	220	mA	-
Power Consumption	-	1512	1860	2310	mW	-
LED voltage	-	8.4	9.3	10.5	V	Note 1
LED Life Time	-	20,000	-	-	Hr	Note 2,3,4

Note 1 : There are 1 Groups LED

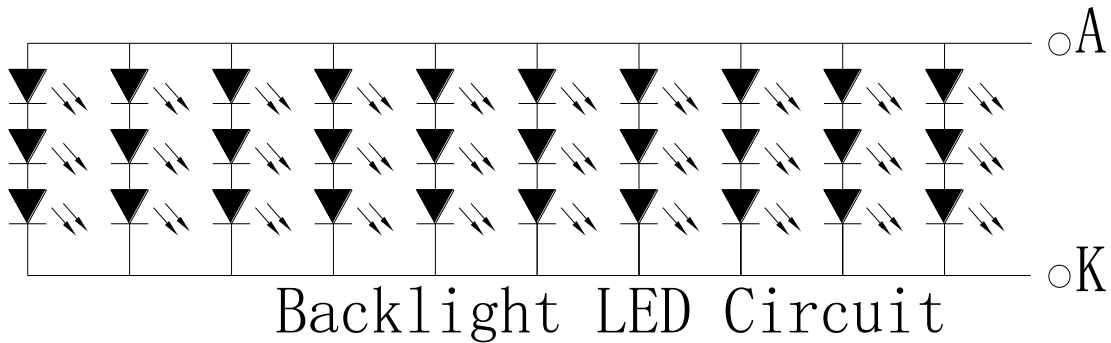

Note 2 : $T_a = 25\text{ }^\circ\text{C}$

Note 3 : Brightness to be decreased to 50% of the initial value

Note 4 : The single LED lamp case

6.DC CHARATERISTICS

Parameter	Symbol	Rating			Unit	Condition
		Min	Typ	Max		
Low level input voltage	V_{IL}	0	-	0.3VCC	V	
High level input voltage	V_{IH}	0.7VCC	-	VCC	V	

7. Timing Characteristics

7.1. Timing Conditions

Symbol	Parameter	Min	Typ	Max	Unit
F _{dclk}	DCLK frequency	-	40	45	MHz
T _{cph}	DCLK cycle	22	25	-	ns
T _{cw}	DCLK pulse width	8	-	-	ns
T _{su}	Data set-up time	4	-	-	ns
T _{hd}	Data hold time	2	-	-	ns
T _{ld}	Time that the last data to LD	1	-	-	Tcph
T _{wld}	Pulse width of LD	2	-	-	Tcph
T _{lds}	Time that LD to STHL/R	5	-	-	Tcph
T _{psu}	POL set-up time	6	-	-	ns
T _{phd}	POL hold time	6	-	-	ns
F _{vclk}	CKV frequency	-	-	200	KHz
T _{rck}	CKV rise time	-	-	100	ns
T _{fck}	CKV falling time	-	-	100	ns
P _{WCLK}	CKV pulse width	500	-	-	ns
T _{dh}	Horizontal display timing range	-	800	-	Tcph
T _h	Horizontal timing range	-	1056	-	Tcph
T _{suv}	STVU/D setup time	200	-	-	ns
T _{hdv}	STVU/D hold time	300	-	-	ns
T _{dt}	STVU/D delay time	-	-	500	ns
T _{do}	Driver output delay time	-	-	900	ns
T _{th}	Output rise time	-	500	1000	ns
T _{thl}	Output falling time	-	400	800	ns
T _{wcl}	OEV pulse width	1	-	-	ns
T _{oe}	OEV to Driver output delay time	-	-	900	us
T _v	Horizontal lines per field	512	525	610	Line
T _{vd}	Vertical display timing range	-	480	-	Line

7.2. Timing Diagram1

<EDGSL="0",Default>

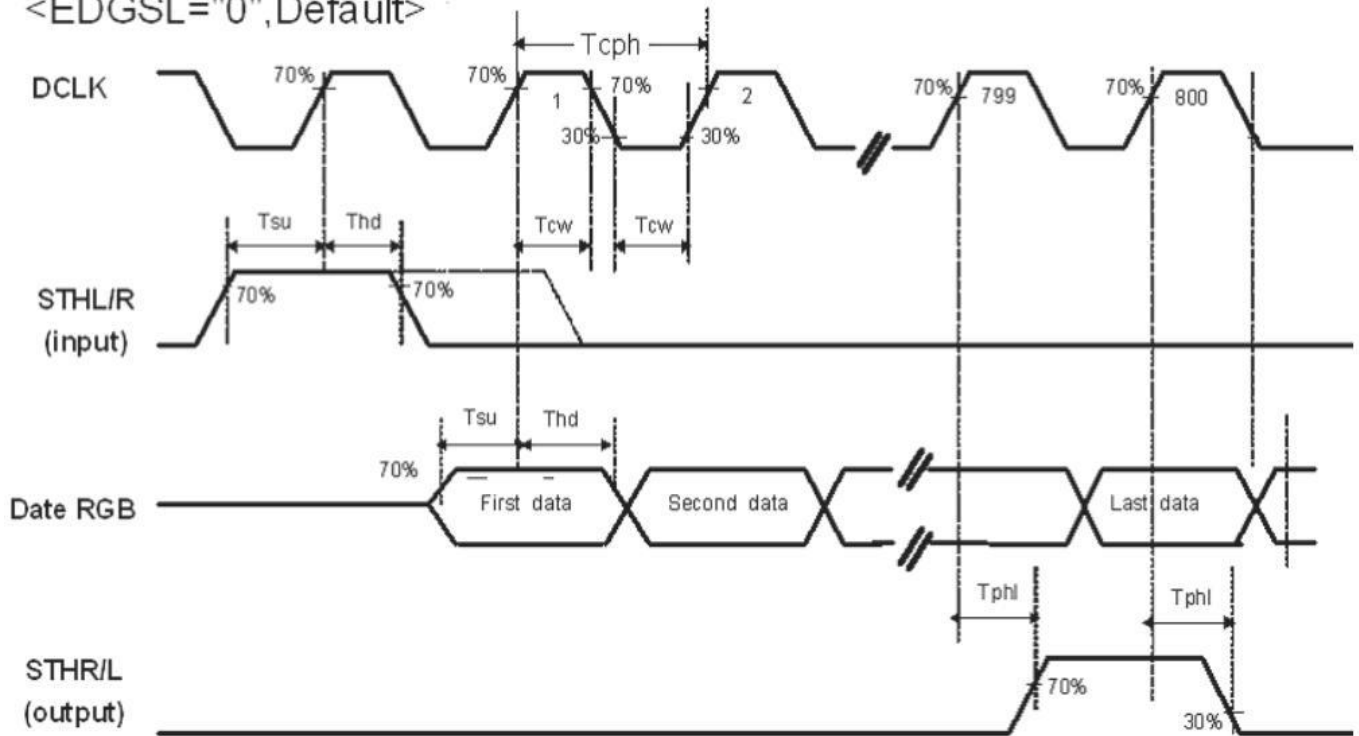

Fig.1 operation model 1

< EDGSL ="1">

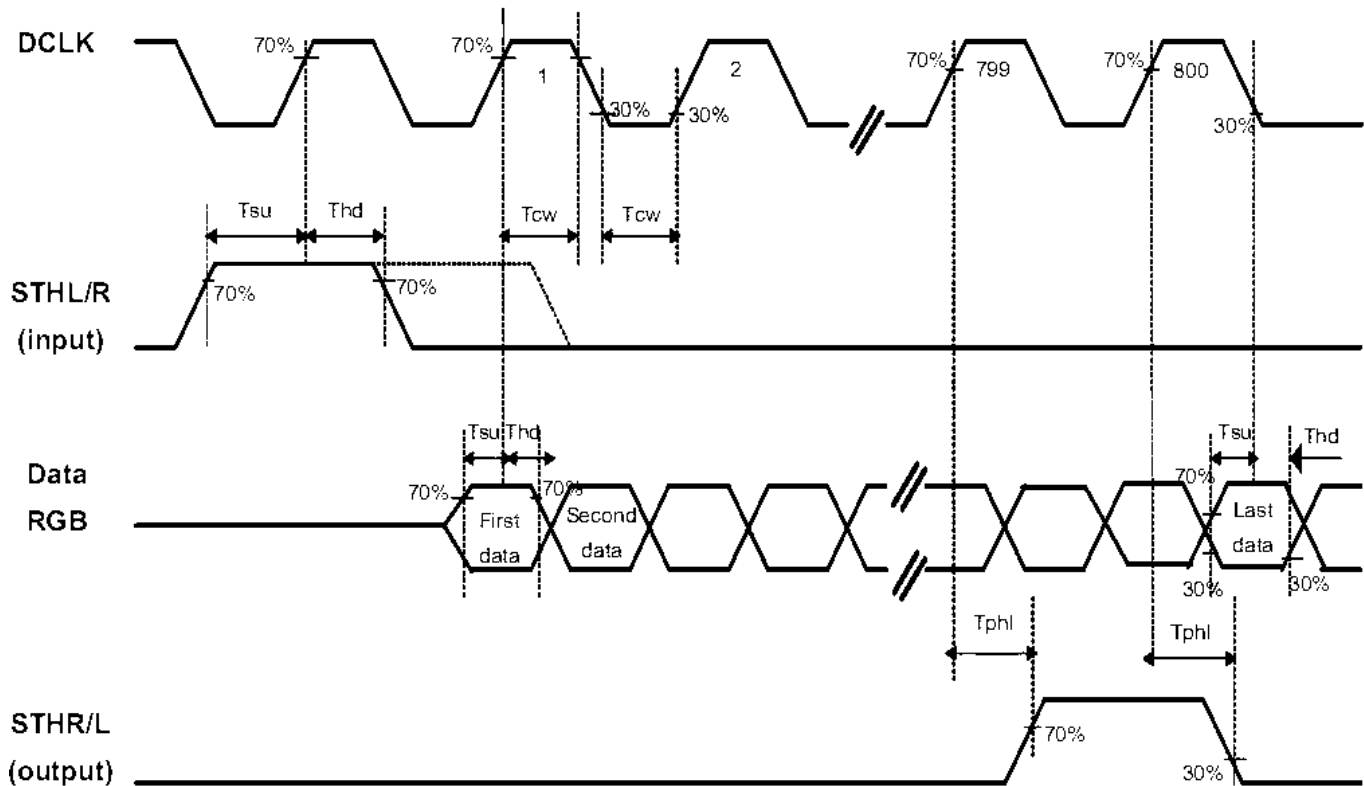

Fig.2 operation model 2

7.3. Timing Diagram2

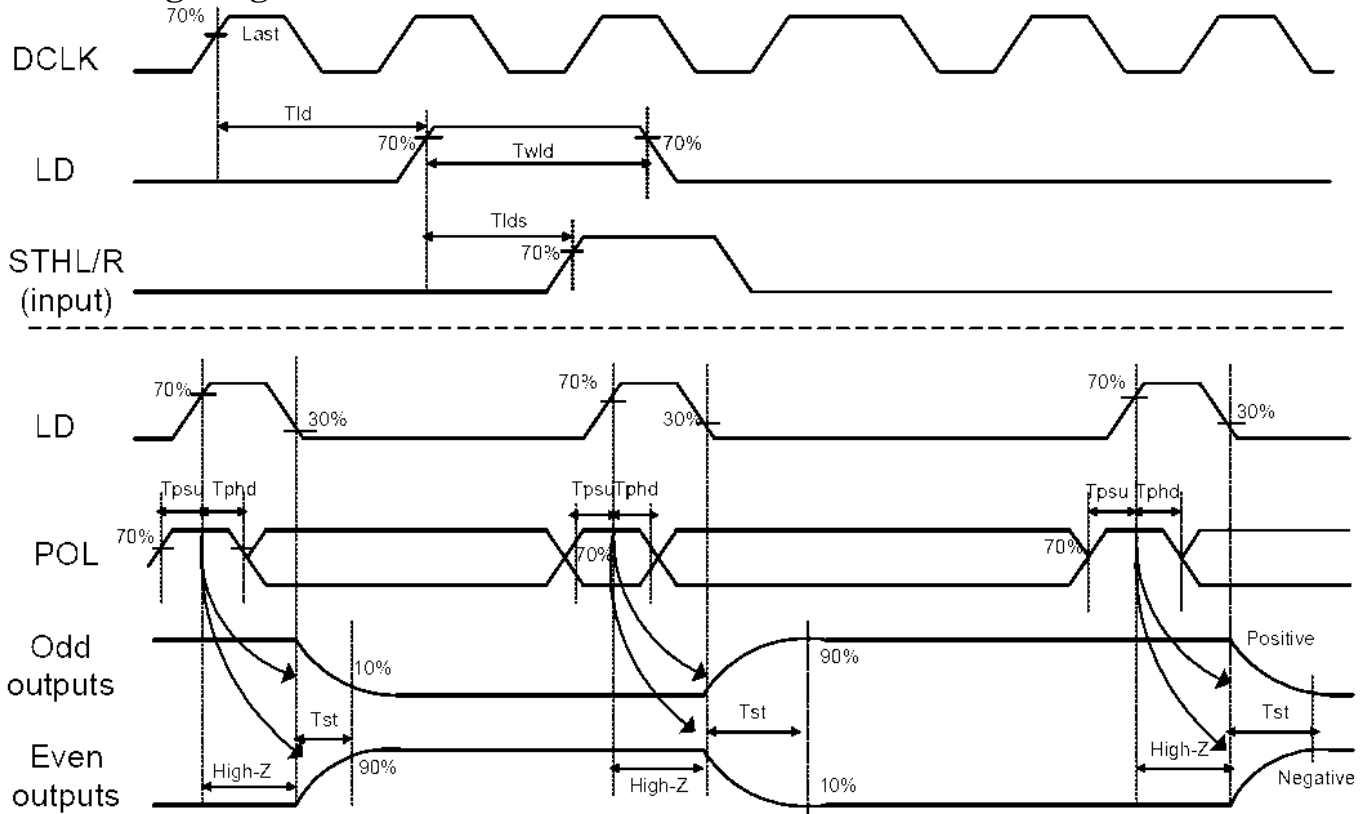

Fig.3 Horizontal timing 1

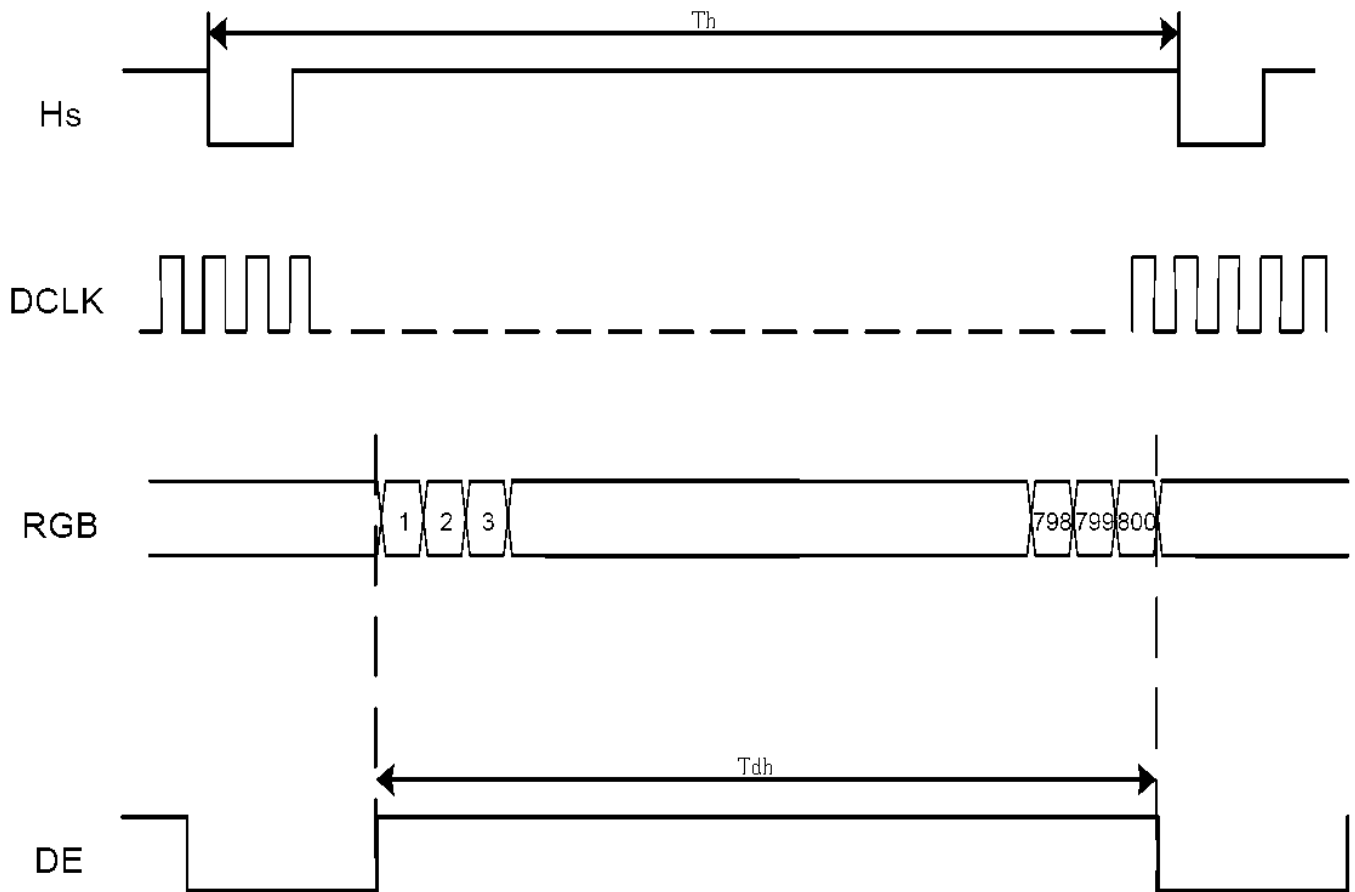

Fig.4 Horizontal timing 2

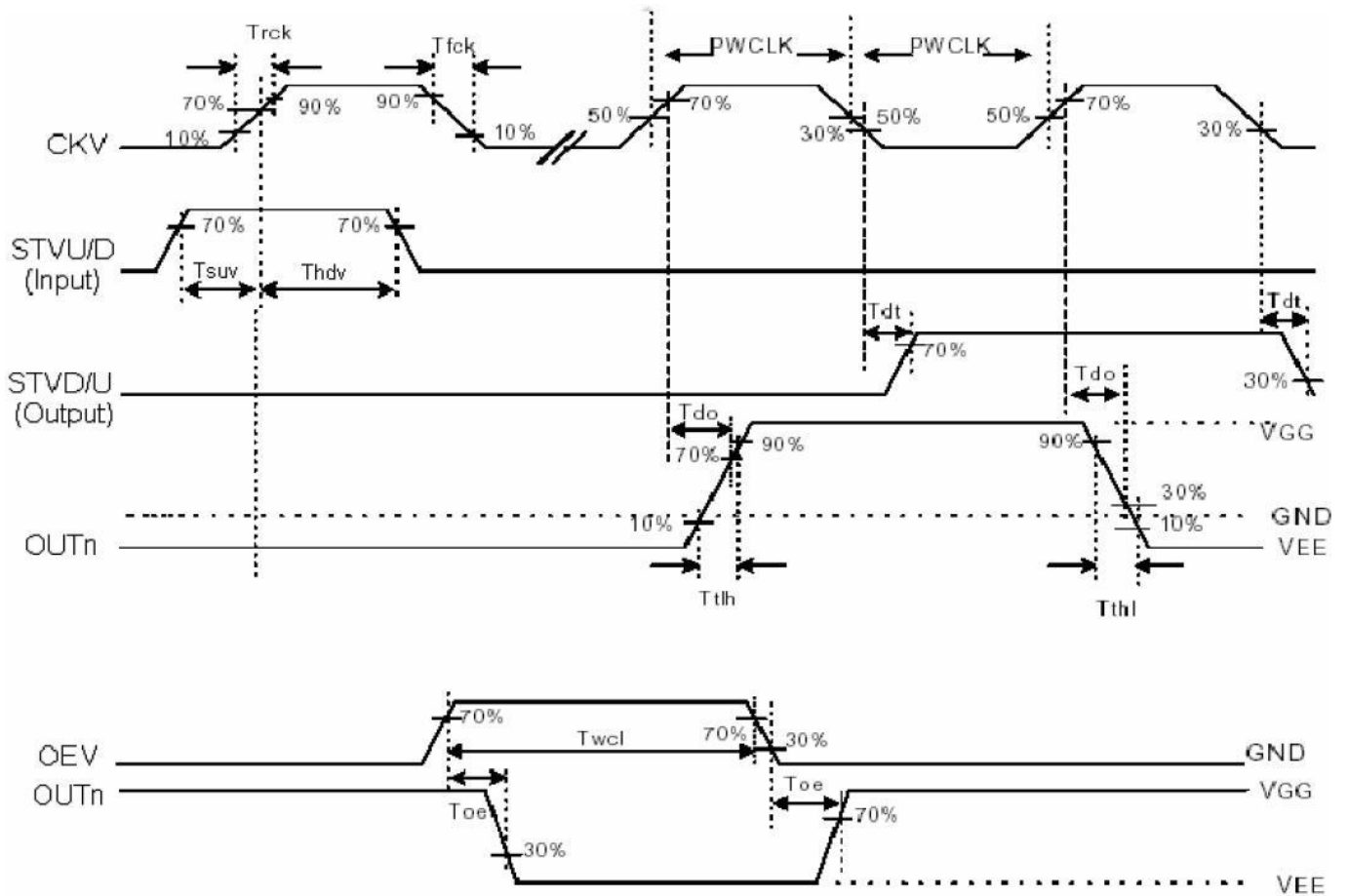

Fig.5 Vertical shift clock timing

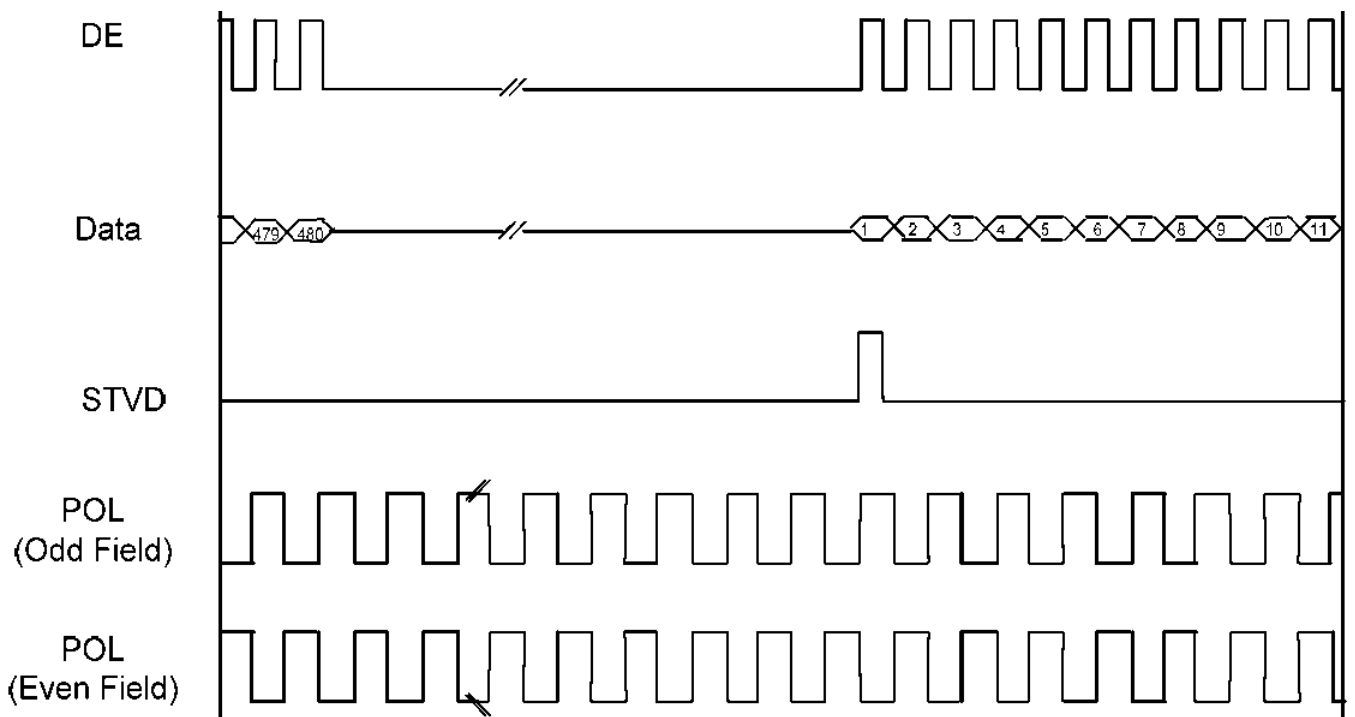

Fig.6 Vertical timing (from up to down)

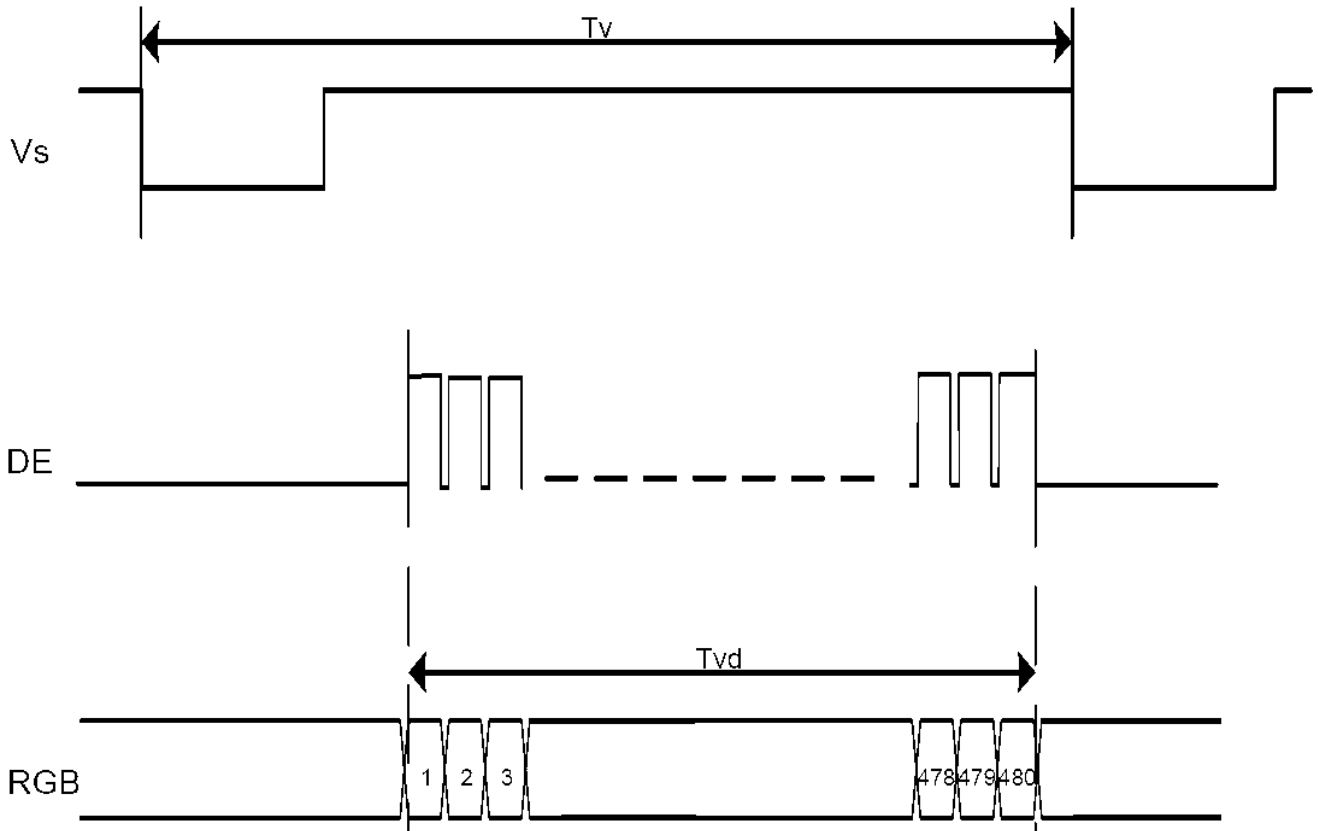

Fig.7 Vertical timing

8. Optical Characteristics

TFT LCD characteristic (Without Capacitive Touch Panel)

Item	Symbol	Condition.	Min	Typ.	Max.	Unit	Remark	
Response time	Tr	$\theta = 0^\circ, \Phi = 0^\circ$	-	15	30	ms	Note 3,5	
	Tf		-	20	40	ms		
Contrast ratio	CR	At optimized viewing angle	250	300	-	-	Note 4,5	
Color Chromaticity	White	$\theta = 0^\circ, \Phi = 0^\circ$	Wx	0.26	0.31	0.36	-	Note 2,6,7
			Wy	0.28	0.33	0.38	-	-
Viewing angle (Gray Scale Inversion Direction)	Hor.	$CR \geq 10$	ΘR	55	65	-	Deg.	Note 1
			ΘL	55	65	-		
	Ver.		ΦT	35	45	-		
			ΦB	55	65	-		
Brightness	-	-	225	280	-	cd/m ²	Center of display	

Ta=25±2°C, IL=200mA

Note 1: Definition of viewing angle range

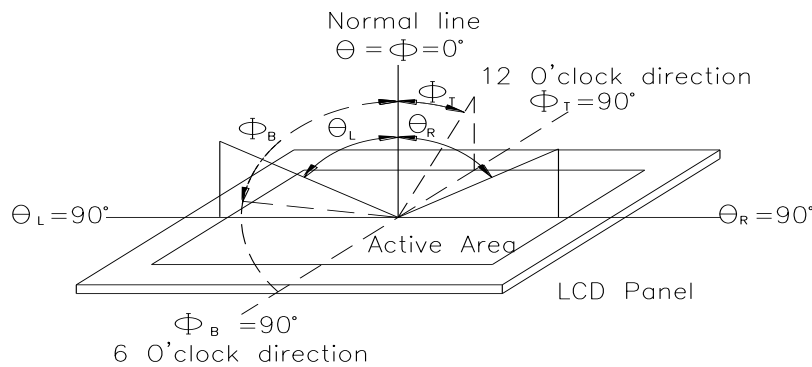

Fig.8.1. Definition of viewing angle

Note 2: Test equipment setup:

After stabilizing and leaving the panel alone at a driven temperature for 10 minutes, the measurement should be executed. Measurement should be executed in a stable, windless, and dark room. Optical specifications are measured by Topcon BM-7 or BM-5 luminance meter 1.0° field of view at a distance of 50cm and normal direction.

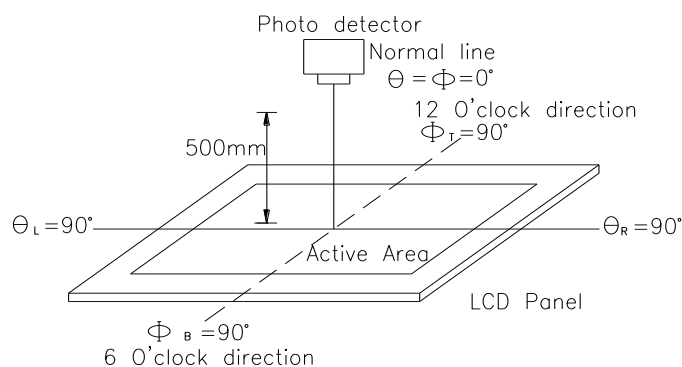
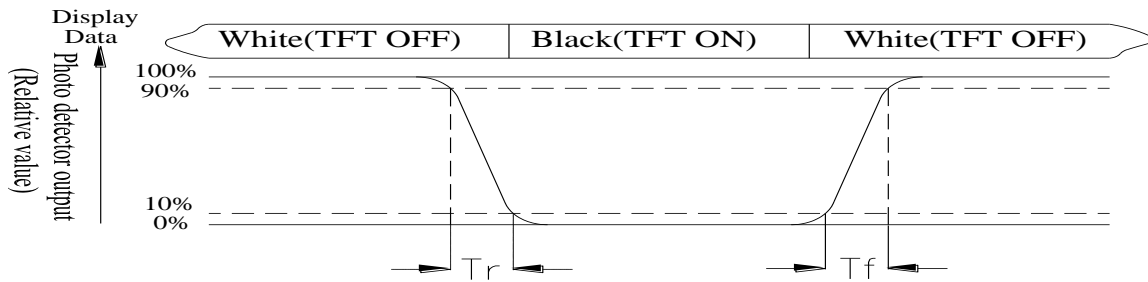

Fig. 8.2. Optical measurement system setup

Note 3: Definition of Response time:

The response time is defined as the LCD optical switching time interval between “White” state and “Black” state. Rise time, T_r , is the time between photo detector output intensity changed from 90% to 10%. And fall time, T_f , is the time between photo detector output intensity changed from 10% to 90%



Note 4: Definition of contrast ratio:

The contrast ratio is defined as the following expression.

$$\text{Contrast ratio (CR)} = \frac{\text{Luminance measured when LCD on the "White" state}}{\text{Luminance measured when LCD on the "Black" state}}$$

Note 5: White $V_i = V_{i50} \pm 1.5V$

Black $V_i = V_{i50} \pm 2.0V$

“±” means that the analog input signal swings in phase with VCOM signal.

“±” means that the analog input signal swings out of phase with VCOM signal.

The 100% transmission is defined as the transmission of LCD panel when all the input terminals of module are electrically opened.

Note 6: Definition of color chromaticity (CIE 1931)

Color coordinates measured at the center point of LCD

Note 7: Measured at the center area of the panel when all the input terminals of LCD panel are electrically opened.

9. Interface

9.1. TFT LCD Panel Driving Section

FPC connector is used for the module electronics interface. The recommended model is “AF 730L-A2G1T” manufactured by P-TWO.

Pin No.	Symbol	I/O	Function	Remark
1	POL	I	Polarity selection	
2	STVD	I/O	Vertical start pulse input when U/D= H	Note 1
3	OEV	I	Output enable	
4	CKV	I	Vertical clock	
5	STVU	I/O	Vertical start pulse input when U/D= L	Note 1
6	GND	P	Power ground	
7	EDGSL	I	Select rising edge or rising/falling edge	
8	V _{CC}	P	Power supply for digital circuit	
9	V ₉	I	Gamma voltage level 9	
10	V _{GL}	P	Gate OFF voltage	
11	V ₂	I	Gamma voltage level 2	
12	V _{GH}	P	Gate ON voltage	
13	V ₆	I	Gamma voltage level 6	
14	U/D	I	Up/down selection	Note 1,2
15	V _{COM}	I	Common voltage	
16	GND	P	Power ground	
17	AV _{DD}	P	Power supply for analog circuit	
18	V ₁₄	I	Gamma voltage level 14	
19	V ₁₁	I	Gamma voltage level 11	
20	V ₈	I	Gamma voltage level 8	
21	V ₅	I	Gamma voltage level 5	
22	V ₃	I	Gamma voltage level 3	
23	GND	P	Power ground	
24	R ₅	I	Red data(MSB)	
25	R ₄	I	Red data	
26	R ₃	I	Red data	
27	R ₂	I	Red data	
28	R ₁	I	Red data	
29	R ₀	I	Red data(LSB)	
30	GND	P	Power ground	
31	GND	P	Power ground	

32	G5	I	Green data(MSB)	
33	G4	I	Green data	
34	G3	I	Green data	
35	G2	I	Green data	
36	G1	I	Green data	
37	G0	I	Green data(LSB)	
38	STHL	I/O	Horizontal start pulse input when R/L = L	Note 1
39	REV	P	Control signal are inverted or not	Note 3
40	GND	I	Power ground	
41	DCLK	I	Sample clock	
42	VCC	P	Power supply for digital circuit	
43	STHR	I/O	Horizontal start pulse input when R/L = H	Note 1
44	LD	I	Latches the polarity of outputs and switches the new data to outputs	
45	B5	I	Blue data (MSB)	
46	B4	I	Blue data	
47	B3	I	Blue data	
48	B2	I	Blue data	
49	B1	I	Blue data	
50	B0	I	Blue data (LSB)	
51	R/L	I	Right/ left selection	Note 1,2
52	V1	I	Gamma voltage level 1	
53	V4	I	Gamma voltage level 4	
54	V7	I	Gamma voltage level 7	
55	V10	I	Gamma voltage level 10	
56	V12	I	Gamma voltage level 12	
57	V13	I	Gamma voltage level 13	
58	AVDD	P	Voltage for analog circuit	
59	GND	P	Power ground	
60	VCOM	I	Common voltage	

I: input, O: output, P: Power

Note 1: Selection of scanning mode

Setting of scan control input		IN/OUT state for start pulse				Scanning direction
U/D	R/L	STVD	STVU	STHR	STHL	
GND	V _{cc}	O	I	I	O	Up to down, left to right
V _{cc}	GND	I	O	O	I	Down to up, right to left
GND	GND	O	I	O	I	Up to down, right to left
V _{cc}	V _{cc}	I	O	I	O	Down to up, left to right

Note 2: Definition of scanning direction.

Refer to the figure as below:

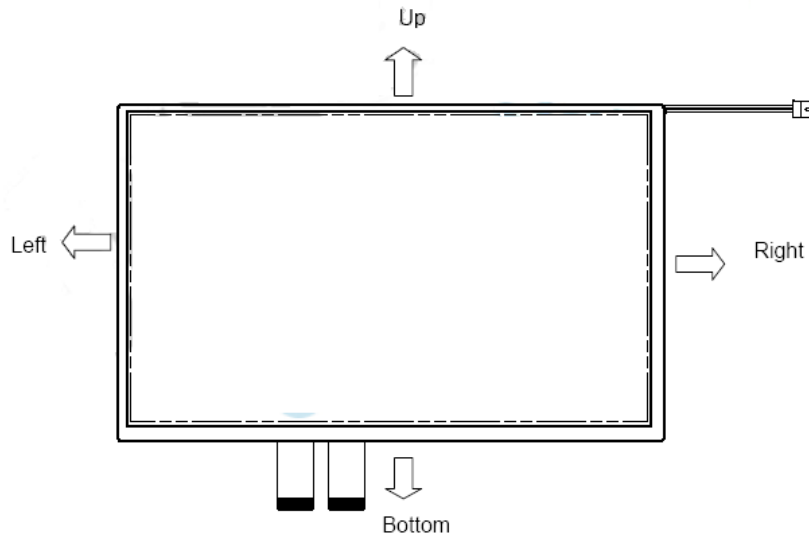

Note 3: When REV="L", normally REV="H", these data will be inverted.

9.2. Backlight Unit Section

LED Light Bar connector is used for the the integral backlight system. The recommended model is "BHSR-02VS-1" manufactured by JST.

Pin No.	Symbol	I/O	Function	Remark
1	V _{LED+}	P	Power for LED backlight anode	Pink
2	V _{LED-}	P	Power for LED backlight cathode	White

9.3. CTP PIN Definition

Pin	Symbol	Function	Remark
1	VSS	Ground for analog circuit	
2	VDDT	Power Supply : +3.3V	
3	SCL	SPI Slave mode, chip select, active low / I2C clock input	
4	NC	No connect	
5	SDA	SPI Slave mode, data input / I2C data input and output	
6	NC	No connect	
7	/RESET	External Reset, Low is active	
8	NC	No connect	
9	/INT	External interrupt to the host	
10	VSS	Ground for analog circuit	

10. Block Diagram

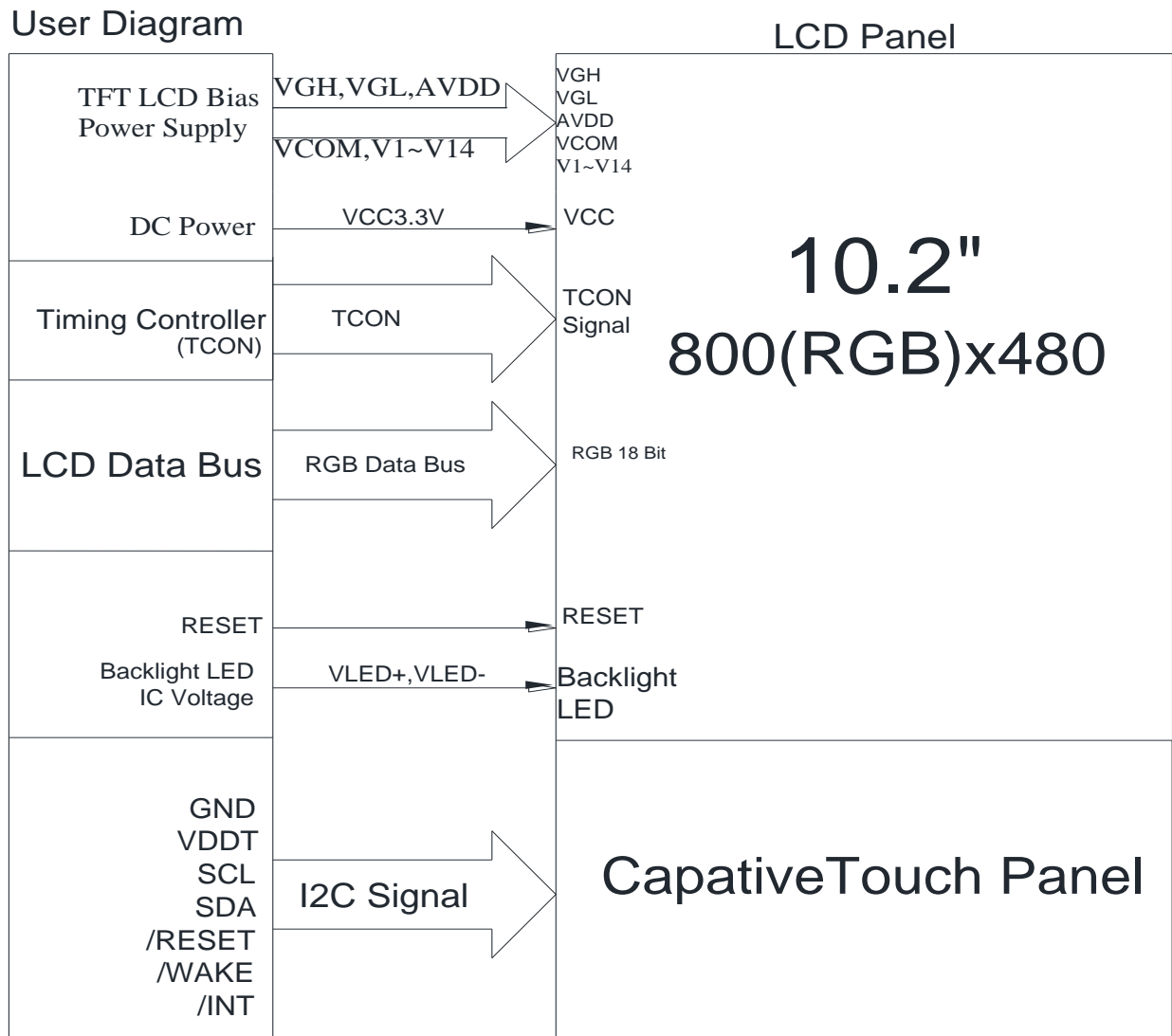

11. Reliability

Content of Reliability Test (Wide temperature, -20°C ~70°C)

Environmental Test			
Test Item	Content of Test	Test Condition	Note
High Temperature storage	Endurance test applying the high storage temperature for a long time.	85°C 200hrs	2
Low Temperature storage	Endurance test applying the low storage temperature for a long time.	-30°C 200hrs	1,2
High Temperature Operation	Endurance test applying the electric stress (Voltage & Current) and the thermal stress to the element for a long time.	70°C 200hrs	—
Low Temperature Operation	Endurance test applying the electric stress under low temperature for a long time.	-20°C 200hrs	1
High Temperature/ Humidity Operation	The module should be allowed to stand at 60 °C, 90%RH max For 96hrs under no-load condition excluding the polarizer, Then taking it out and drying it at normal temperature.	60°C, 90%RH 96hrs	1,2
Thermal shock resistance	The sample should be allowed stand the following 10 cycles of operation <div style="text-align: center;"> <p style="text-align: center;">-20°C 25°C 70°C</p> <p style="text-align: center;">30min ← 5min → 30min</p> <p style="text-align: center;">1 cycle</p> </div>	-20°C /70°C 10 cycles	—
Vibration test	Endurance test applying the vibration during transportation and using.	Total fixed amplitude : 15mm Vibration Frequency : 10~55Hz One cycle 60 seconds to 3 directions of X,Y,Z for Each 15 minutes	3
Static electricity test	Endurance test applying the electric stress to the terminal.	VS=800V, RS=1.5kΩ CS=100pF 1 time	—

Note1: No dew condensation to be observed.

Note2: The function test shall be conducted after 4 hours storage at the normal Temperature and humidity after remove from the test chamber.

Note3: The packing have to including into the vibration testing.

12.Touch Panel Information

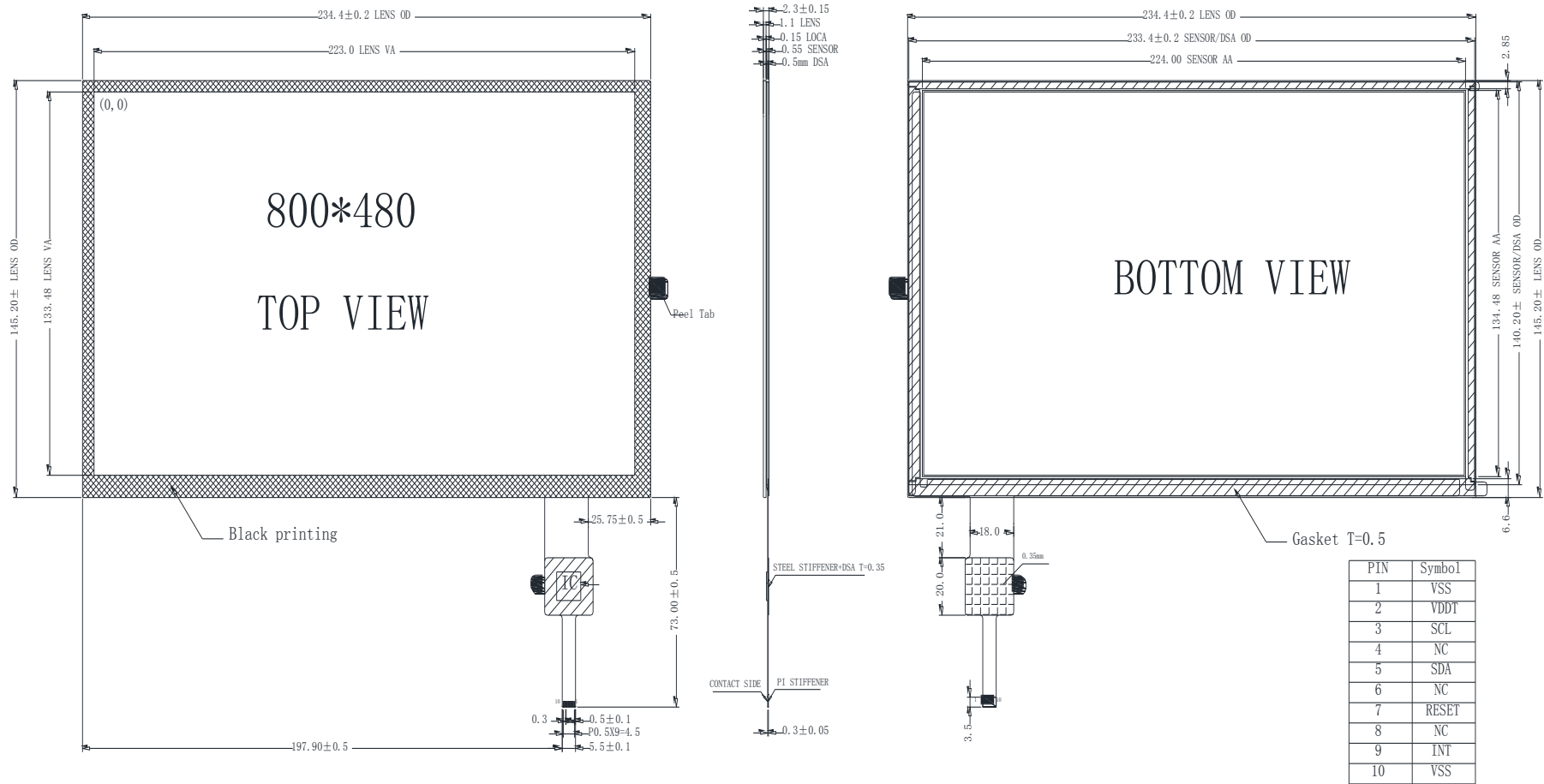

12.1. CTP I2C Timing:

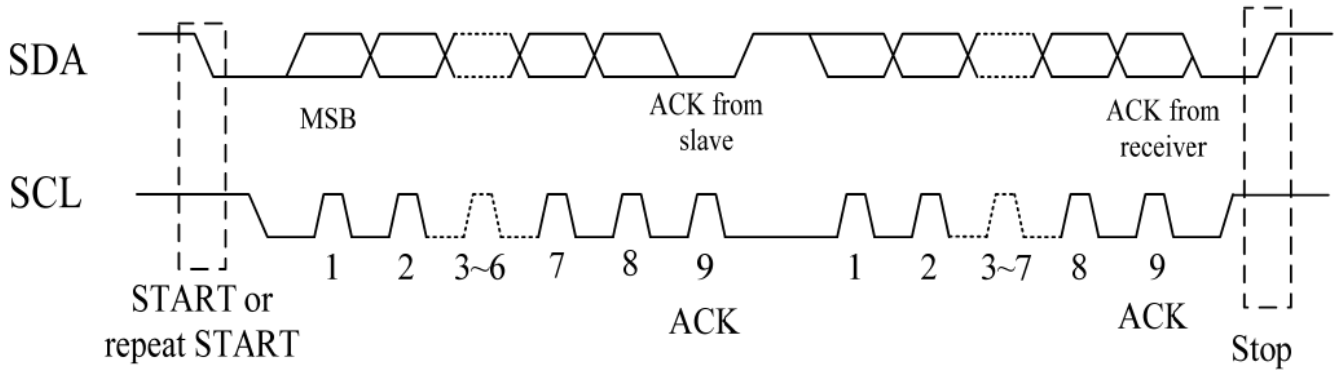

I2C Serial Data Transfer Format

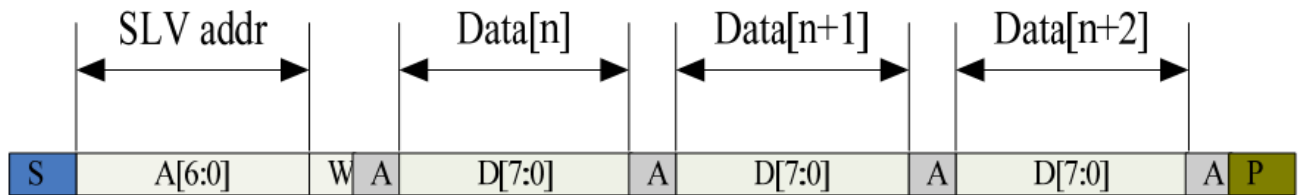

I2C master write, slave read

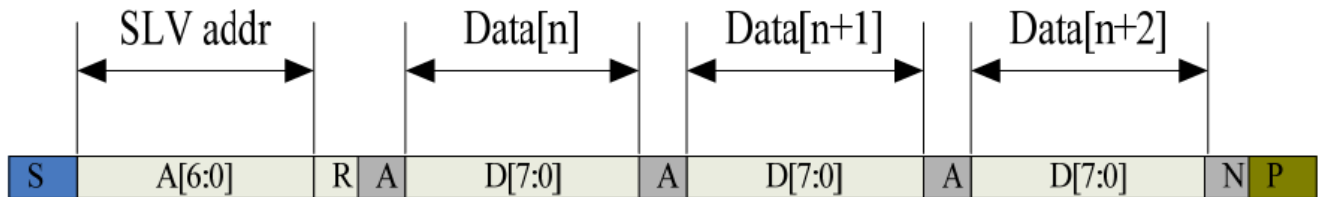

I2C master read, slave write

Mnemonics	Description
S	12C Start or 12C Restart
A[6:0]	Slave address A[6:4]:3'b011 A[3:0]:data bits are identical to those of 12CON[7:4]register
W	1'b0:Write
R	1'b1:Read
A(N)	ACK(NACK)
P	STOP :the indication of the end of a packet(if this bit is missing, S will indicate the end of the current packet and beginning of the next packet)

Lists the meanings of the mnemonics used in the above figures

Parameter	Unit	Min	Max
SCL frequency	KHz	0	400
Bus free time between a STOP and START condition	us	4.7	\
Hold time (repeated) START condition	us	4.0	\
Data setup time	ns	250	\
Setup time for a repeated START condition	us	4.7	\
Setup time for STOP condition	us	4.0	\

Interface Timing Characteristics

AS FOR STANDARD CTPM, HOST NEED TO USE BOTH INTERRUPT CONTROL SIGNAL AND SERIAL DATA INTERFACE TO GET THE TOUCH DATA.

HERE IS THE TIMING TO GET TOUCH DATA.

12.2. WRITE BYTES TO I2C SLAVE

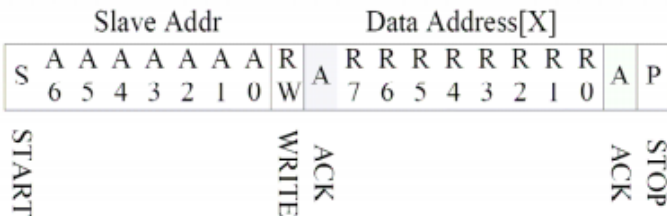
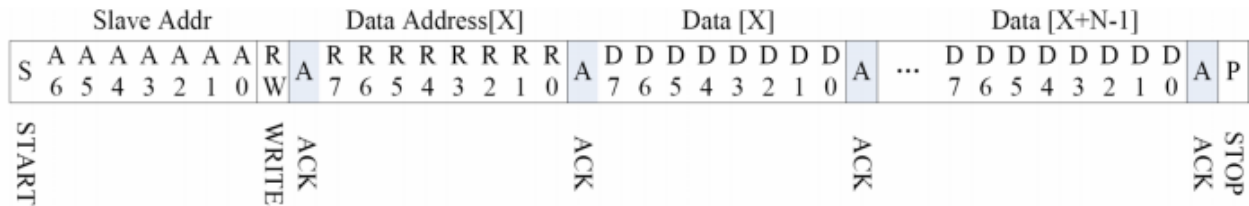

READ X BYTES FROM I2C SLAVE

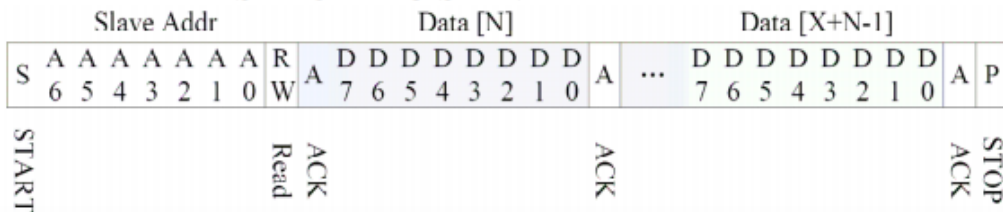

AS FOR STANDARD CTPM, HOST NEED TO USE BOTH INTERRUPT CONTROL SIGNAL AND SERIAL DATA INTERFACE TO GET THE TOUCH DATA, HERE IS THE TIMING TO GET TOUCH DATA.

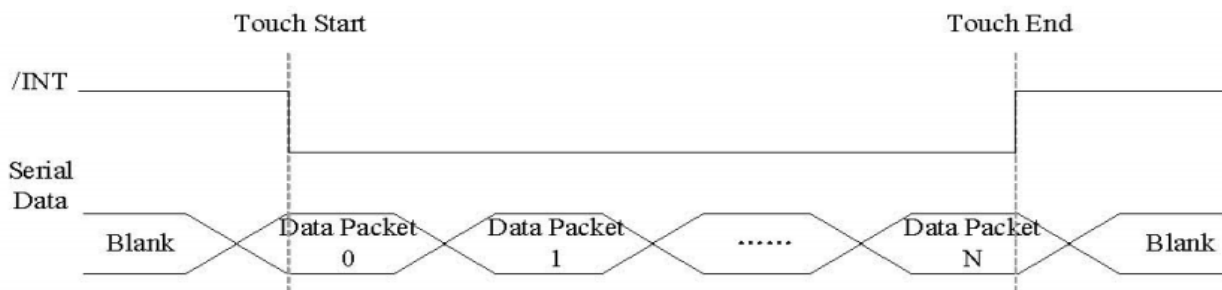

Address: 0X38

TOUCH DATA READ PROTOCOL

NAME	VALUE	DESCRIPTION
START CH	0X00	START COMMAND FOR CTPM TOUCH DATA PACKET,HOST MUST SEND CTPM A START CH COMMAND BEFORE READ TOUCH DATA
1st READ BYTE~ LAST READ BYTE		TOUCH DATA PACKET SENT BY CTPM,EACH BYTE HAS 8-BIT DATA ,A TOUCH DATA PACKET CONSISTS OF N BYTE

A DATA PACKET STARTS WITH A HEADER AND ENDS WITH CRC CODE,AS FOR 5 POINTS DATA PACKET,THE LENGTH OF THE PACKET IS ALWAYS 26 BYTES IN SPITE OF ACTUAL TOUCH POINTS.

Address	Name	Bit7	Bit6	Bit5	Bit4	Bit3	Bit2	Bit1	Bit0	Host Access
00h	Devide__Mode		Device Model[2:0]							RW
01h	Gest__ID	Gesture ID[7:0]								R
02h	TD__Status					Number of touch points[3:0]				R
03h	Touch1__XH	1 st Event Flag				1 st Touch X Position[11:8]				R
04h	Touch1__XL	1 st Touch X Position[7:0]								R
05h	Touch1__YH	1 st Touch ID[3:0]			1 st Touch Y Position[11:8]				R	
06h	Touch1__YL	1 st Touch Y Position[7:0]								R
09h	Touch2__XH	2 nd Event Flag				2 nd Touch X Position[11:8]				R
0Ah	Touch2__XL	2 nd Touch X Position[7:0]								R

0Bh	Touch2__YH	2nd Touch ID[3:0]	2ndTouch Y Position[11:8]	R
0Ch	Touch2__YL	2nd Touch Y Position[7:0]		R
0Fh	Touch3__XH	3rdEvent Flag	3rdTouch X Position[11:8]	R
10h	Touch3__XL	3rd Touch X Position[7:0]		R
11h	Touch3__YH	3rdTouch ID[3:0]	3rdTouch Y Position[11:8]	R
12h	Touch3__YL	3rd Touch Y Position[7:0]		R
15h	Touch4__XH	4thEvent Flag	4thTouch X Position[11:8]	R
16h	Touch4__XL	4th Touch X Position[7:0]		R
17h	Touch4__YH	4thTouch ID[3:0]	4thTouch Y Position[11:8]	R
18h	Touch4__YL	4th Touch Y Position[7:0]		R
1Bh	Touch5__XH	5thEvent Flag	5thTouch X Position[11:8]	R
1Ch	Touch5__XL	5th Touch X Position[7:0]		R
1Dh	Touch5__YH	5thTouch ID[3:0]	5thTouch Y Position[11:8]	R
1Eh	Touch5__YL	5th Touch Y Position[7:0]		R

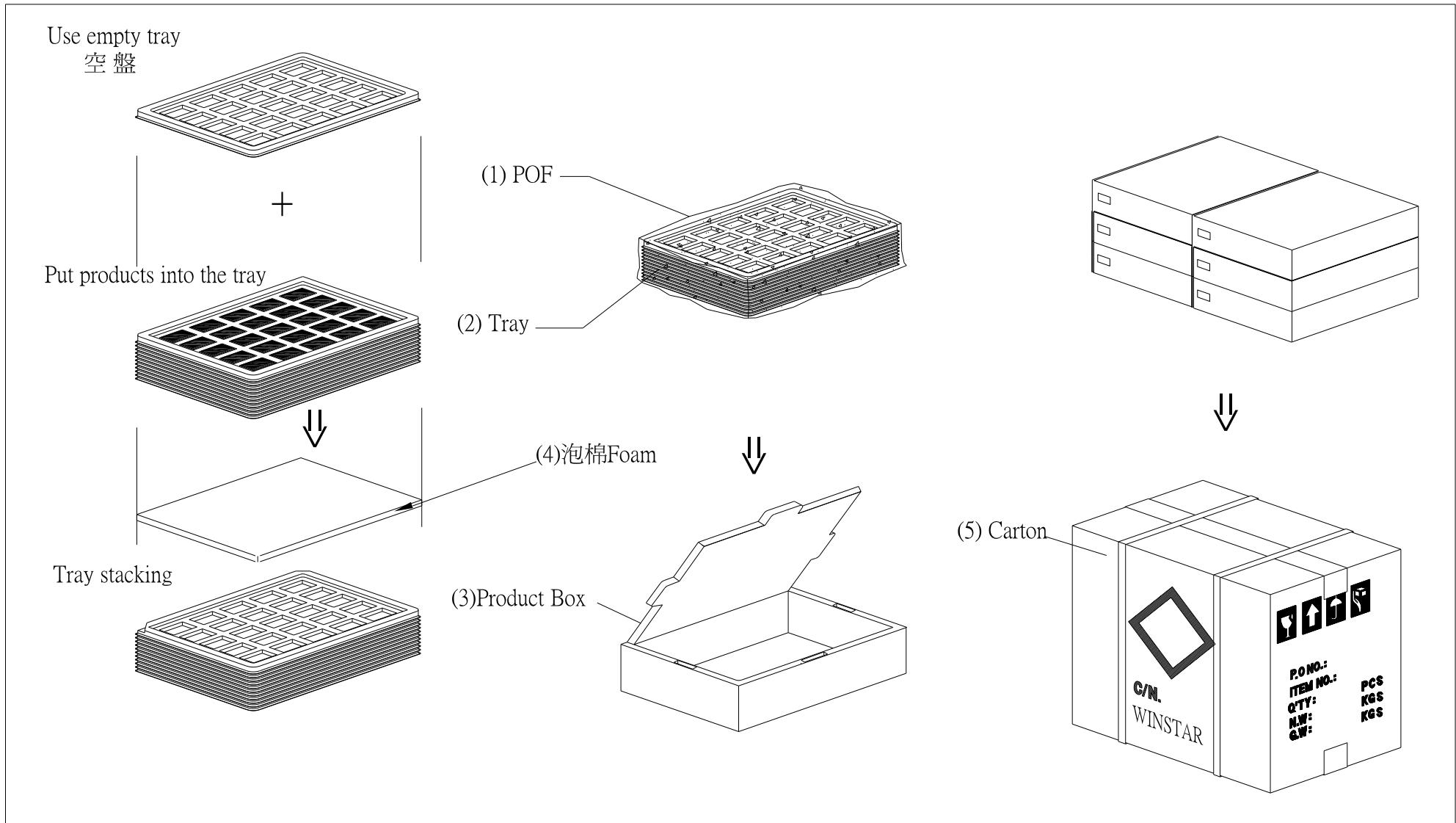



1、Panel Specification :

- 1. Panel Type : Pass NG , _____
- 2. View Direction : Pass NG , _____
- 3. Numbers of Dots : Pass NG , _____
- 4. View Area : Pass NG , _____
- 5. Active Area : Pass NG , _____
- 6. Operating Temperature : Pass NG , _____
- 7. Storage Temperature : Pass NG , _____
- 8. Others : _____

2、Mechanical Specification :

- 1. PCB Size : Pass NG , _____
- 2. Frame Size : Pass NG , _____
- 3. Material of Frame : Pass NG , _____
- 4. Connector Position : Pass NG , _____
- 5. Fix Hole Position : Pass NG , _____
- 6. Backlight Position : Pass NG , _____
- 7. Thickness of PCB : Pass NG , _____
- 8. Height of Frame to PCB : Pass NG , _____
- 9. Height of Module : Pass NG , _____
- 10. Others : Pass NG , _____

3、Relative Hole Size :

- 1. Pitch of Connector : Pass NG , _____
- 2. Hole size of Connector : Pass NG , _____
- 3. Mounting Hole size : Pass NG , _____
- 4. Mounting Hole Type : Pass NG , _____
- 5. Others : Pass NG , _____

4、Backlight Specification :

- 1. B/L Type : Pass NG , _____
- 2. B/L Color : Pass NG , _____
- 3. B/L Driving Voltage (Reference for LED Type) : Pass NG , _____
- 4. B/L Driving Current : Pass NG , _____
- 5. Brightness of B/L : Pass NG , _____
- 6. B/L Solder Method : Pass NG , _____
- 7. Others : Pass NG , _____

>> **Go to page 2** <<



Winstar Module Number : _____

Page: 2

5、Electronic Characteristics of Module :

- 1. Input Voltage : Pass NG , _____
- 2. Supply Current : Pass NG , _____
- 3. Driving Voltage for LCD : Pass NG , _____
- 4. Contrast for LCD : Pass NG , _____
- 5. B/L Driving Method : Pass NG , _____
- 6. Negative Voltage Output : Pass NG , _____
- 7. Interface Function : Pass NG , _____
- 8. LCD Uniformity : Pass NG , _____
- 9. ESD test : Pass NG , _____
- 10. Others : Pass NG , _____

6、Summary :

Sales signature : _____

Customer Signature : _____

Date : / / _____